

NATIONAL RADIO ASTRONOMY OBSERVATORY
Green Bank, West Virginia

Electronics Division Internal Report No. 97

MILLIMETER-WAVE SPECTRAL-LINE RECEIVER —
LOCAL OSCILLATOR AND IF SECTIONS

S. Weinreb

OCTOBER 1970

NUMBER OF COPIES: 150

MILLIMETER-WAVE SPECTRAL-LINE RECEIVER —
LOCAL OSCILLATOR AND IF SECTIONS

TABLE OF CONTENTS

	<u>Page</u>
I. <u>Introduction</u>	1
II. <u>RF Assembly Specifications</u>	1
III. <u>Local Oscillator Stabilization System</u>	2
A. Function	2
B. Operational Description	3
C. PLL Block Diagram Description	6
D. Loop Compensation Adjustments	10
IV. <u>Receiver IF Section</u>	12
A. Block Diagram Description	12
B. Paramp Performance	14

LIST OF FIGURES

1	Photograph of Front-End Box	15
2	Typical RF Assembly	16
3	The Calibration of IF Level	17
4	Phase-Lock-Loop Block Diagram	18
5(a)	Photograph of Phase-Lock Loop - Top Cover Removed	19
5(b)	Photograph of Phase-Lock Loop - Bottom Cover Removed	20
6	Photograph of Local Oscillator Stabilizer Control Panel	21
7	Block Diagram of IF Portion of Receiver	22
8	Photograph of IF Portion of Front-End Box	23
9	Characteristics of Sylvania SYG-2030 Avalanche Diode Source, 004....	24
10	Paramp Response at Various Gain Settings, March 7, 1970	25

SCHEMATICS

S2. 547-1	Triplexer for Harmonic Mixer	26
S2. 547-2	Phase Lock Loop Monitor Wiring	27
S2. 547-3	Lock Indication Circuitry	28
S2. 547-4	2 GHz LO Reference Unit	29
S2. 547-5	Switch Driver	30
S2. 547-6	Search Signal Generator	31
S2. 547-7	Loop Amplifier	32
S2. 547-8	Phase-Lock Loop Power Wiring	33
S2. 547-9	Varactor Bias - Supply and Monitor	34
S2. 547-10	Avalanche Diode Power Supply	35

CABLE RECORD

Telescope Cable, 15 Pair, Front-End	36
Front-End Box, Phase-Lock-Loop Box	37
Front-End Box, Near IF Section	38

MILLIMETER-WAVE SPECTRAL-LINE RECEIVER — LOCAL OSCILLATOR AND IF SECTIONS

S. Weinreb

I. Introduction

A receiver system which can be used with interchangeable RF assemblies over a wide range of frequencies is described in this report. The major topics of the report are the local oscillator stabilization system and the parametric IF amplifier. The RF assemblies are not described in detail; however, the general requirements and interface specifications are given.

A photograph of a complete front-end box is shown in Figure 1. The box is approximately 14" x 14" x 60", weighs approximately 100 pounds, and can be used on the NRAO 36' and 140' telescopes.

II. RF Assembly Specifications

A block diagram of a typical RF assembly is shown in Figure 2. The beam-switch is only needed for antenna pointing calibration on continuum sources; frequency switching is usually utilized for spectral line observations. A means of modulating the noise calibration signal is required. This may be accomplished by a ferrite modulator following a gas-discharge noise lamp or by bias voltage modulation of an avalanche diode noise source. A filter of some sort is usually required on the local oscillator signal in order to suppress klystron noise at signal and image frequencies. This may be accomplished with two rejection filters or a bandpass filter. It may also be possible to utilize the filter to inject local oscillator signal into the mixer with tight coupling and little loss of signal in the local oscillator line.

The RF assembly connects to the remainder of the receiver with the following interface requirements:

- a) Mixer-IF Connection — The parametric amplifier input impedance is 50 ohms at 1.39 GHz through a type N connector. A DC short is provided through the paramp and a DC block may be required to provide mixer bias voltage and current monitoring. An isolator may be required to reduce paramp bandpass changes as the mixer IF impedance changes through frequency switching of the local oscillator.

- b) Harmonic Mixer Interface — The harmonic mixer connects to the local oscillator stabilizer through a single OSM connector. The stabilizer supplies up to 25 mW of drive power in the 1.95 - 2.00 GHz range and accepts a signal level of -70 dBm or more in the 300-500 MHz range. (With care, lock can be obtained with -80 dBm of signal.) A DC monitoring of crystal current of 0 to 20 mA is provided on this same coaxial line. The 2 GHz drive power can be adjusted from the control room.
- c) Klystron Power Supply — The receiver contains power supplies providing 6.30 volts DC at 5 amps (isolated for up to 5000 volts from ground), 0-3100 volts at 40 mA beam voltage, 0-2100 volts reflector voltage, and grid voltage as required by a zener diode tap on the reflector supply. These connections are made through a Winchester PM 6P connector on the klystron with the following pin connections:

- A — Reflector
- B — Cathode
- C — Grid
- D — Heater
- E — Heater-Cathode
- F — Case Ground

The front-end box contains 115 V AC for a klystron fan and ± 15 volts for a mixer bias supply.

III. Local Oscillator Stabilization System

A. Function

The stabilization system is a phase-locked-loop (PLL) which has sufficient sensitivity, separation of lock points, correction voltage range, and bandwidth to frequency-switch millimeter-wave klystrons.

The system locks the klystron to the N'th harmonic of a frequency, f_1 , near 2 GHz plus or minus a frequency, f_2 , near 400 MHz. The plus or minus lock is

indicated by front-panel indicators and an audio alarm is energized if the klystron is not locked. Either f_1 or f_2 can be switched at a rate of up to a few hundred cps and the loop will relock, typically, in less than 0.5 ms.

The range of f_1 is limited primarily by a bandpass filter in the system. A bandpass filter covering the range 1870-2010 MHz is usually installed. The offset frequency, f_2 , can be in the range, 300-500 MHz. (Sub-harmonics of the IF frequency should be avoided.) The frequency-switching separation will usually be limited by klystron mode width (typically 100 MHz) or correction voltage range (50 volts). Most klystrons have reflector modulation sensitivities of 1.0 to 10 MHz/volt and thus this limitation is 50 to 500 MHz.

The PLL incorporates a search signal which, if the loop is unlocked, sweep the correction voltage over its entire range. When the loop locks, the search signal is still added in the loop but will be cancelled by a phase detector error signal of approximately $\pm 20^\circ$. The search signal may be manually turned off but this is only advisable in applications requiring phase stability. The search signal is triggered by the reference square-wave which drives the frequency-switch. A manual SEARCH SYNC switch is provided so that the search sweep goes in the correct direction to lock to the new frequency.

B. Operational Description

A description of the operating controls of the system, given in the approximate order that they are used, is as follows (refer to Figure 6):

- (1) Klystron Power Switch — When this switch is turned on a reduced filament voltage is applied to the klystron (~ 5 volts). After a 10 second delay, full filament voltage is applied and AC power is supplied to the reflector supply (Fluke, 410B). The HIGH VOLTAGE switch of this supply must be in the STANDBY position until the light-orange indicator is on. It should then be switched to ON and AC power is applied to the beam supply (which can be left with all switches ON). It is

- (1) Continued —
 best to slowly bring up high voltage on the beam supply. To turn the klystron off, bring the beam voltage down and turn the KLYSTRON POWER switch to OFF.
- (2) Open-Normal Loop Switch — It is usually most convenient to adjust the klystron with the PLL inoperative. In the OPEN LOOP position a fixed correction voltage of 30 volts (in the middle of the 5 to 55 volt range) is applied. The klystron should then be adjusted for correct power and approximately correct frequency with a wavemeter. The switch should then be put in the NORMAL position.

- (3) Search-Trigger and Search-Phase Switches — The SEARCH TRIGGER switch is normally left in the EXT REF position. The search signal is then triggered by the reference signal which drives the f_2 frequency switch. The SEARCH PHASE switch must then be set according to the following table:

Lock to:	f_2 (signal) > f_2 (comparison)	f_2 (signal) < f_2 (comparison)
$Nf_1 + f_2$	+	-
$Nf_1 - f_2$	-	+

The search signal may be triggered at an asynchronous 1 kHz rate by using the INT position of the SEARCH TRIGGER switch.

- (4) Frequency Switch — This switch determines whether the source of the f_2 offset frequency is from the SIGNAL input jack, from the comparison input jack, or modulated between these at the rate of the signal coming in the EXT REF jack. The level of the f_2 signal is indicated on the 400 MHz LEVEL meter; a reading between 20 and 90 is appropriate. A calibration curve for the meter as a function of drive power is shown in Figure 3(a). For initial adjustments of the loop it is usually best to check that the loop operates at both SIGNAL and COMPARISON positions before going to the MODULATE position.

- (5) PLL IF Monitor Jack — This jack monitors the IF signal which is produced by the mixing of the klystron and N'th harmonic of f_1 . It is usually connected to a spectrum analyzer centered at frequency, f_2 (i. e. , 400 MHz), with dispersion of 100 MHz, resolution of 100 kHz, log display, and a 1 to 10 ms/cm sweep rate. The signal level is approximately 35 dB above the level at the harmonic-mixer output assuming 10 dB cable loss to the front-end box. A normal display will show a single carrier at frequency, f_2 , 40 dB to 60 dB above noise in a 100 kHz bandwidth (-118 dBm at harmonic-mixer output). This should correspond to a reading between 20 and 90 on the IF LEVEL meter. (See Figure 3(a) for a calibration of this meter.) Final adjustments of the klystron cavity and reflector supply voltage should be made to obtain a proper display.
- (6) Harmonic Mixer Meter and Drive Control — The meter reads harmonic mixer current with 20 mA full scale. The MIXER DRIVE screwdriver adjust control varies the bias on the f_1 driver amplifier to provide 1 to 25 mW drive to the harmonic mixer. The drive should be adjusted to the minimum value which gives adequate PLL IF signal level. Curves of IF signal, harmonic mixer current, and drive power as a function of amplifier drive current (i. e. , MIXER DRIVE setting) for an 85 GHz harmonic mixer are shown in Figure 3(b).
- (7) Correction Voltage Meter and Reflector Monitor Jack — The correction voltage meter reads the voltage which is applied in series with the reflector DC supply. This supply should be adjusted so the correction voltage is in the

- (7) Continued — center (30) of its 5 to 55 volt range. The REFLECTOR MONITOR jack allows monitoring of the correction voltage at 1 volt/10 volts. It should show a 5 volt search trapezoidal wave when the loop is out of lock and a 0.5 to 5.5 volt DC voltage when the loop is in lock.
- (8) Quadrature Meter, Lock Indicators, and Alarm — The quadrature meter reads ± 10 volts full scale and is used as a lock indicator. The meter will read 0 ± 1 volt when the loop is unlocked, $> +5$ volts when locked to $Nf_1 + f_2$, and < -5 volts when locked to $Nf_1 - f_2$. Indicator lights and an audio alarm also show these conditions. The audio ALARM VOLUME is adjustable and the alarm is shut off when the LOOP switch is in the OPEN position. The QUADRATURE monitor jack can be used to view the dynamic lock performance when frequency switching.

C. PLL Block Diagram Description

A block diagram of the local oscillator stabilization system is shown in Figure 4. Photographs of the front-end box portion and control room portions are shown in Figures 5(a), 5(b) and 6. Each component is briefly described below:

- (1) Triplexer (Schematic 2.547-1) — This unit separates the 2 GHz supplied to the harmonic mixer from the 400 MHz and DC outputs.
- (2) Bandpass Filter (Itel FBT/2-1990/30-4/50-28A/28A) — This is a 4-pole filter with 30 MHz 1 dB bandwidth centered at 1990 MHz. (Wider bandwidth units are used for continuous frequency coverage at lower LO frequencies; i. e., 140 MHz for a 20 GHz LO.) The filter is to suppress any spurious signals on the 2 GHz source.

- (3) Power Amplifier (Hewlett-Packard HP35005A) — This unit functions as an amplifier, power limiter, and drive control for the harmonic mixer. With normal bias (+20 volts, -285 mA) the unit is a 45 dB gain, 50 mW output, .1-2 GHz amplifier. In the system it is operated with +15 volts (little effect) and an adjustable negative current supply of -70 to -290 mA. A 3 dB pad is usually used at its output (to protect the harmonic mixer diode) and a 10 dB pad at its input (for good match and to protect the amplifier). Approximately 1 mW is needed at the 10 dB pad input for proper operation. (See Figure 3(b).)
- (4) Low Pass Filter (Itel FLT/2-600-9/50) — This filter is used to prevent the high power 2 GHz signal from entering the low noise 400 MHz amplifier.
- (5), (6), (8), and (11)
Amplifier-Limiter (Fairchild MHA-300B-02) — These units have 26 dB gain over the 100 to 500 MHz band and saturate at +6 to +10 dBm output. They require +12 volts at 45 mA.
- (7) Bandpass-Filter (Itel FBT/2-400/200-5/50-28A/28A) — This unit rejects sub-harmonics of 400 MHz which may produce false lock points.
- (9), (10)
Phase Detectors (Werlatone DBM-5) — These are double-balanced mixers operated with \sim +4 dBm input and .7 volt peak-to-peak output.
- (12) DC Amplifier (Schematic 2.547-2) — This is a simple gain of -36 operational amplifier circuit to boost the quadrature phase detector output to the \pm 10 volt level.

- (13) Lock Indicator (Schematic 2.547-3) — The quadrature phase detector signal is 0 ± 1 volt if the loop is unlocked, is negative several volts if locked to $Nf_1 + f_2$, and positive several volts if locked to $Nf_1 - f_2$. These levels are sensed and applied to indicator lamps and the audio alarm. The alarm is turned off when the LOOP switch is in the OPEN position.
- (14) 2 GHz Source (Schematic 2.547-4) — This unit utilizes a Fairchild phase-locked oscillator which locks to a harmonic of an external 95 to 105 MHz signal. The oscillator can be mechanically tuned from 1.72 to 2.02 GHz but has its output restricted to a smaller range by a bandpass filter (to prevent operation on an incorrect harmonic). The oscillator can be locked to one of eight internal crystal oscillators in the 98.95 to 100 MHz range or to an external synthesizer.
- (15), (16) 400 MHz Sources — For frequency-switched operation two sources supplying 1 mW (sufficient with up to 12 dB cable loss to the front-end) in the 300 to 500 MHz range are required. Initially two Hewlett-Packard 3200B oscillators (~ 10 kHz stability) will be used. Two inexpensive digital synthesizers are being developed for later use.
- (17) Switch Driver (Schematic 2.547-5) — The switch driver input requirement is 0 V SIGNAL and -6 V COMPARISON. The diode switch has ~ 43 dB isolation and 0.4 dB loss.
- (18) Search Generator (Schematic 2.547-6) — Initially, it was thought that a ramp which scanned the correction voltage range in several milliseconds would be required. It was experimentally found that a very fast ramp ($\sim 10 \mu\text{s}$)

(18) Continued —

worked best; the loop filter slows the ramp to a rate which permits capture. The search generator output is a ± 10 volt square wave with adjustable 10 to 1000 μ s rise and fall times. The gain from search generator output to the reflector correction voltage is ~ 5 . The search signal referred to the phase detector output is ± 25 mV which is large enough to overcome phase detector offsets but small compared to the phase detector output range of ± 350 mV.

(19) Loop Amplifier (Schematic 2.547-7) — This amplifier has a DC gain of ~ 2000 and a DC output capability of 50 volts. Switch-selected resistor (R) and capacitor (C) compensation elements force the DC gain to drop off at 6 dB per octave from frequencies $1/2\pi \times 10^5 \times C$ to $1/2\pi RC$. Above $1/2\pi RC$ the gain is $R/70$ up to a frequency of 30 MHz or more.

(20), (21)

Power Inverters (Arnold Magnetics PHU-6.3 and SHU-.15) — The 6.3 volt unit provides up to 5 amps of klystron filament power and the 150 volt unit provides 15 mA for the loop amplifier. Both units have outputs isolated for up to 5000 volts from ground or the +28 volt input. Schematic 2.547-8 shows connections to the inverters.

(22) 28 V DC Supply (Lambda LM-219) — This supplies up to 2 amps for the inverters. A ± 15 volt, 0.4 amp supply (Lambda LCD-4-152) is also contained in the PLL control chassis and can be used for PLL front-end box power. (Usually, general ± 15 volt front-end box power supplies are used.)

(23) Reflector Supply (Fluke 410B) — This provides up to -2100 volts at 30 mA referred to the negative of the beam supply. A zener-diode tap on the reflector supply is used to power the grid of OKI klystrons.

(24) Beam Supply (Power Designs 1547) — Supplies up to 3100 volts at 40 mA for klystron beam.

D. Loop Compensation Adjustments

The phase-locked loop contains a phase detector with sensitivity, $k_\phi = 0.25$ V per radian, a klystron with modulation sensitivity, $k_0 = 0.5$ to 20 MHz per volt, and a loop amplifier with gain, G_h , above frequency $1/\tau_2$. The quantities G_h and τ_2 are adjustable by switch selected values of R and C and are given by $G_h = R/70$ and $\tau_2 = RC$. The values of R and C which are selected in the six positions of each switch are the following:

Position	R	Position	C
1	10	1	56 μ F
2	30	2	200 μ F
3	100	3	1000 μ F
4	400	4	5000 μ F
5	1.5 K	5	.02 μ F
6	6.2 K	6	.10 μ F

The loop performance is described by the loop bandwidth, f_0 , and damping factor, ξ , which are given by,

$$f_0 = k_0 k_\phi G_h = \frac{k_0 k_\phi R}{70}$$

$$\xi = \frac{\omega_0 \tau_2}{2} = \frac{RC\omega_0}{2} = \frac{k_0 k_\phi R^2 C}{140}$$

A large value of ω_0 makes the loop lock quickly and follow a fast search voltage; a small value makes the loop more tolerant to noise and may make the loop more stable. Values in the range of $2\pi \times 1$ MHz are appropriate for millimeter wave klystrons. A damping factor of $\xi = 1/2$ gives the optimum ratio of response time to noise bandwidth but a value of $\xi = 2$ gives close to optimum performance and is more tolerant to variations in loop parameters.

The following table gives the optimum settings of R and C as a function of klystron sensitivity and desired loop bandwidth:

Klystron Sensitivity MHz/Volt	Typical Klystron	Loop Bandwidth					
		0.3 MHz		1.0 MHz		3.0 MHz	
		R	C	R	C	R	C
0.5	24V11	3 or 4	4 or 5	4	3	5	1 or 2
2	VC713	2 or 3	5 or 6	3	4	4	2 or 3
5	90V11	1 or 2	6	2	5	3 or 4	3
20	---	1	6	1	5 or 6	2 or 3	4

The best settings of R and C can be found by adjusting the switches (this may be done safely with high voltage on) while viewing the loop performance on a spectrum analyzer. An oscilloscope on the quadrature phase-detector monitor jack will indicate loop lock time in the frequency switching mode. This procedure was tried with a 90V11 klystron and good operation was achieved at any of the 0.3 or 1.0 MHz switch settings. The loop was unstable at the 3.0 MHz settings.

A loop bias adjustment is also accessible through an insulated shaft potentiometer. This should be adjusted to give 30 on the correction voltage meter when the loop is unlocked and the search trigger is off. The adjustment is dependent upon the frequency of f_2 but is unimportant to loop operation and may be deleted in future units.

IV. Receiver IF Section

A. Block Diagram Description

A block diagram and photograph of the receiver IF section are shown in Figures 7 and 8. A parametric amplifier operating at a center frequency of 1.39 GHz is used as the first IF amplifier. The paramp gives a low noise temperature (~ 50 °K) at a relatively high IF frequency. The low noise temperature improves the system noise temperature by a factor of approximately 2 as compared with a low-noise 1.39 GHz transistor IF amplifier and the high IF frequency is helpful to the problem of filtering local oscillator noise. The front-end box includes a 1240 MHz crystal-controlled second local oscillator to produce a second IF centered at 150 MHz.

The components of the block diagram are described as follows:

- (25) DC Block — The paramp varactor is DC isolated from the circulator input and output connectors by an internal DC block. However, the circulator input and output connectors are DC connected and the DC short on the transistor amplifier input (and also the 50 ohm circulator termination) is the DC load presented to the mixer. A DC block is thus needed for mixer bias and current monitoring; it is normally incorporated with the mixer.
- (26) Isolator — This component is usually included in the RF assembly plate. It is needed to reduce the effects of modulation of the mixer IF impedance (due to frequency-switching) on the paramp response.
- (27) Circulator — A 4-port circulator is supplied with the Micromega paramp. The input section has a loss of approximately 0.15 dB and an isolation of ~ 35 dB over a 100 MHz bandwidth.
- (28) Varactor Mount — The varactor is a Sylvania Type D5047E having a zero-bias capacitance of 0.75 to 0.80 pF. The varactor should not be removed unless it is absolutely necessary.

- (29) Bias Supply (Schematic 2. 547-9) — This unit supplies 0 to +2 volts of reverse bias voltage to the varactor and allows monitoring of the bias current with 1 μ A full-scale.
- (30) Pump Isolator — Miniature isolator in 18-26.5 GHz waveguide.
- (31) Coupler — A 20 dB cross-guide coupler is incorporated to allow the pump frequency and power to be monitored with an external wavemeter and power meter. The monitor port is normally shorted.
- (32) Avalanche Source — A Sylvania SYG-2030 source, capable of supplying $20,810 \pm 15$ MHz at up to 75 mW of power, is utilized for paramp pump power. The source consists of an X-band avalanche oscillator and a varactor doubler. The power output and frequency as a function of drive current is as shown in Figure 9. The frequency can be adjusted over a small range with a tuning screw.
- (33) Current Limiter (Schematic 2. 547-10) — This unit is needed to protect the avalanche source from transients. The operating voltage on the avalanche source is approximately 100 volts.
- (34) Transistor Amplifier — This unit has 4 dB noise figure and 25 dB gain over the 1300-1500 MHz band.
- (35) 1240 MHz Source (Frequency Sources FS-21G) — This unit supplies 20 mW at 1240.0 MHz with a temperature coefficient of 1 kHz/ $^{\circ}$ C. It should be checked every several months to correct for crystal aging.
- (36) Bandpass Filter (Itel FBT/0.2-1390/200-6/50-28A/28A) — This filter passes 1290 to 1490 MHz and assures > 50 dB image rejection at 1090 MHz.

- (37) Bandpass Filter (Itel FBT/2-1240/40-5/50-28A/28A) — This 40 MHz bandwidth, 5 section filter is for suppression of any spurious signals on the second local oscillator.
- (38) Isolator — This unit terminates filter (36) in a good match to insure a flat passband.
- (39) Mixer (Werlatone DBM-10) — This is a miniature double-balanced mixer specified for use at frequencies up to 1 GHz. However, good performance is obtained at 1.39 GHz.
- (40) and (41)
IF Amplifier (E and M CA-1003) — Each of these units furnishes \sim 26.0 dB over the 10-300 MHz frequency range. Power requirement is 16 mA at +15 volts and output power is +3 dBm for 1 dB gain compression (18 dB above normal output level).

B. Paramp Performance

The parametric amplifier can be adjusted from the control room through two calibrated ten-turn dials which control varactor bias voltage and avalanche diode current (i. e., pump power with a small effect on pump frequency). The gain of the paramp can be adjusted with these controls; typical settings and other parameters for gains of 20 dB to 7 dB are given in Table 1. The frequency response is shown in Figure 10. The exact settings are sensitive to temperature, pump frequency, idler micrometer setting, and adjustments of the circulator. (Adjustments were made in September, 1970, after the table was made.) Thus, the table should be used only to indicate typical values; adjustment of the paramp should be made with a sweep generator or spectrum analyzer.

TABLE I
 Parametric Amplifier Performance as Function of Bias Voltage and Pump Power Control Settings
 March 7, 1970

Gain Mid- band dB	Bias Pot	Pump Pot	Bias Cur. <u>1/</u> nA	Aval. Cur. mA	Pump Power <u>2/</u> mW	Pump Freq. above 20.0 GHz	Low 3 dB MHz	Low 1 dB MHz	High 1 dB MHz	High 3 dB MHz	Bias Volt. <u>3/</u> mV	Noise Temp. <u>4/</u> °K
20	239	614	410	31.5	30.1	.809	1344	1358	1428	1437	520	50
17	222	603	245	30.5	28.4	.803	1329	1343	1435	1450	480	53
14	199	590	130	29.8	25.9	.798	1313	1331	1448	1461	425	66
10	162.5	568	38	28.5	20.4	.792	1289	1309	1460	1472	350	100
7	133	551	10	27.5	16.6	.786	1273	1292	1469	1483	283	165

1/ Meter reads 1000 nA full scale.

2/ Assumes cross-guide coupler is 20 dB.

3/ Measured on bias test point.

4/ Includes second stage noise.

For applications which require < 80 MHz bandwidth, a paramp gain of 17 dB should be used. This is sufficient to overcome the second-stage noise; higher gains will give lower stability. If wider bandwidth is desired, a lower gain can be used. A bandwidth of 205 MHz at half-power points can be obtained with a 33% increase in system temperature assuming a 300° effective IF noise temperature presented by the RF mixer.

The paramp gain can be easily measured by turning the pump power on and off (through the +150 volt supply for avalanche current). The change in receiver total power at mid-band should be ~ 3 dB less than the paramp gain, again assuming a 300° effective IF noise temperature presented by the mixer (almost certainly the case if no LO power is applied.)

The paramp noise temperature was checked with the avalanche diode pump and with a Varian EM 1138E klystron pump. Values of $45^\circ \pm 4^\circ \text{K}$ were obtained for several measurements with both pumps, indicating little or no excess noise due to the avalanche oscillator.

The gain variation of the paramp is approximately 1 dB for .06 dB pump power change or 2 MHz pump frequency change. An avalanche source temperature rise of approximately 5° will cause .06 dB power change and -2 MHz frequency change. Thus, stabilization of pump power alone (through a feedback loop) will do little to increase thermal stability. (This was verified even when varactor current was sensed.) The varactor mount is also temperature sensitive. The conclusion was not to use a pump power stabilization loop and accept a gain stability of the order of 0.2 dB/°C.

The sensitivity of the paramp to input source impedance was tested by measuring the gain (through a directional coupler) as the source impedance is changed from 50 ohms, to 0, and to open circuit. Initially, the paramp would oscillate when open circuited. The circulator isolation was then adjusted by means of the small screws in the case to a value > 39 dB over the 1340-1440 MHz band. The gain variation was then ± 1 dB for the same input impedance variations. (This adjustment is not stable; several months later the variation increased to ± 3 dB and the circulator isolation was adjusted again.)

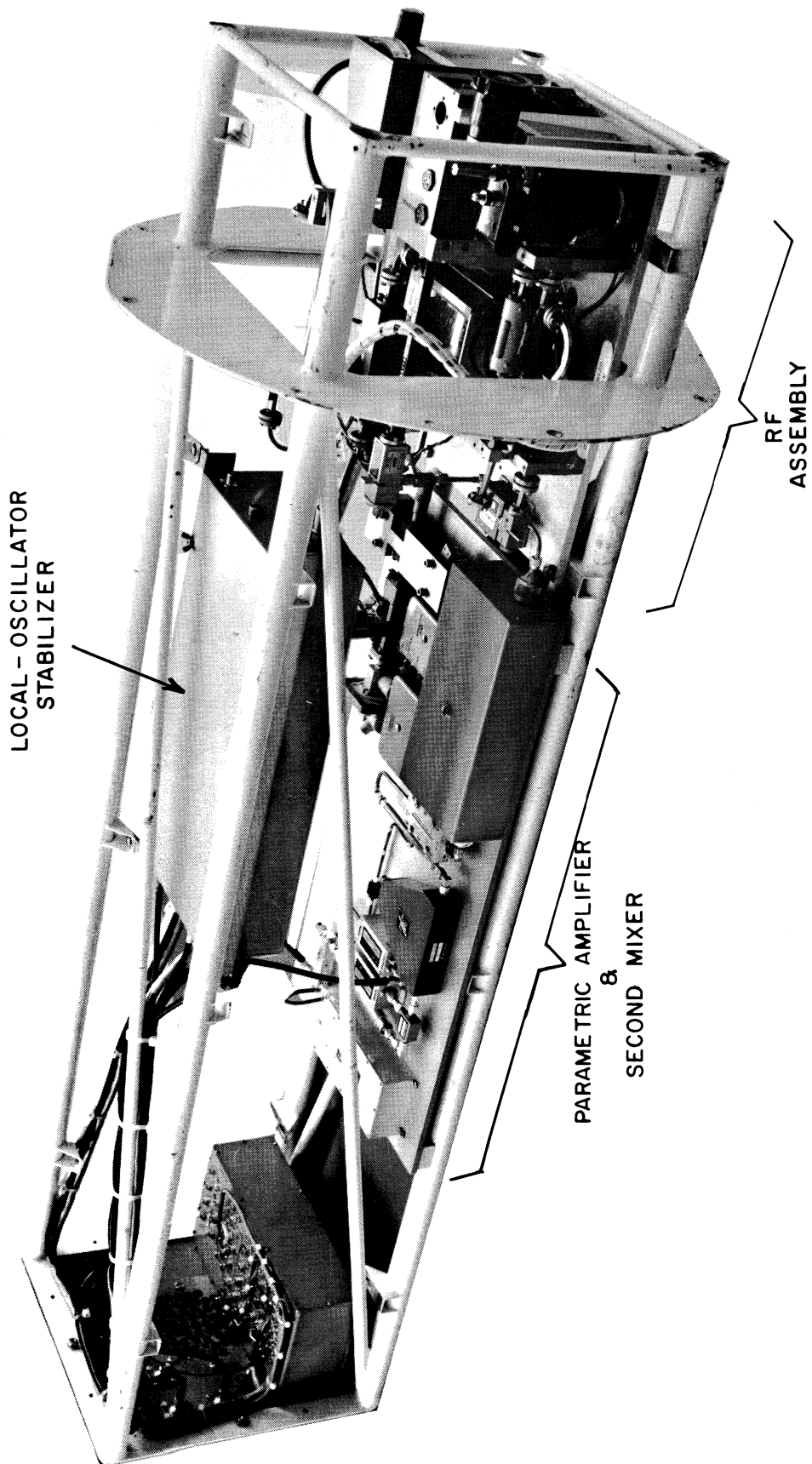

Figure 1 - Front-End Box.

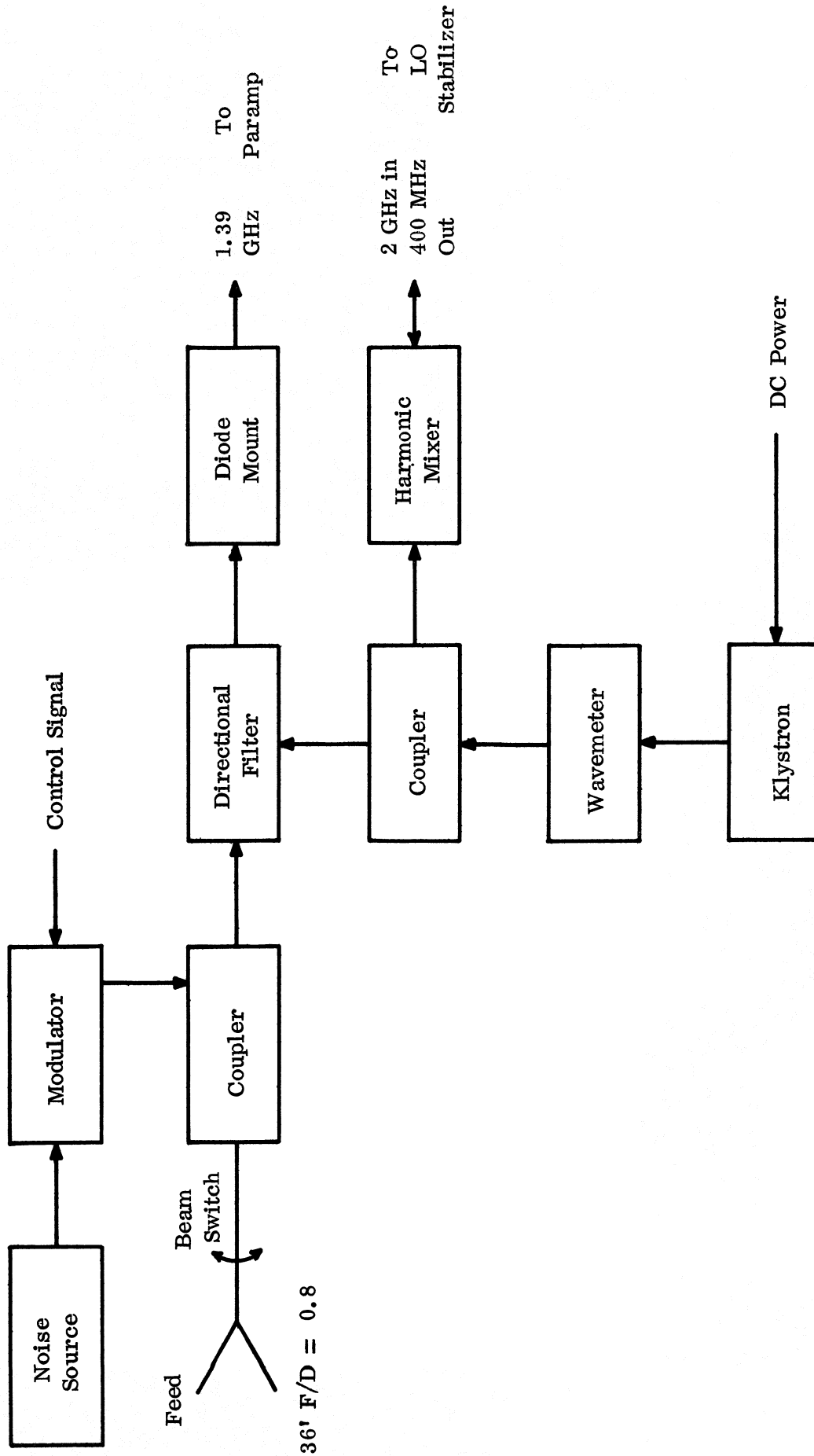

FIGURE 2 - TYPICAL RF ASSEMBLY

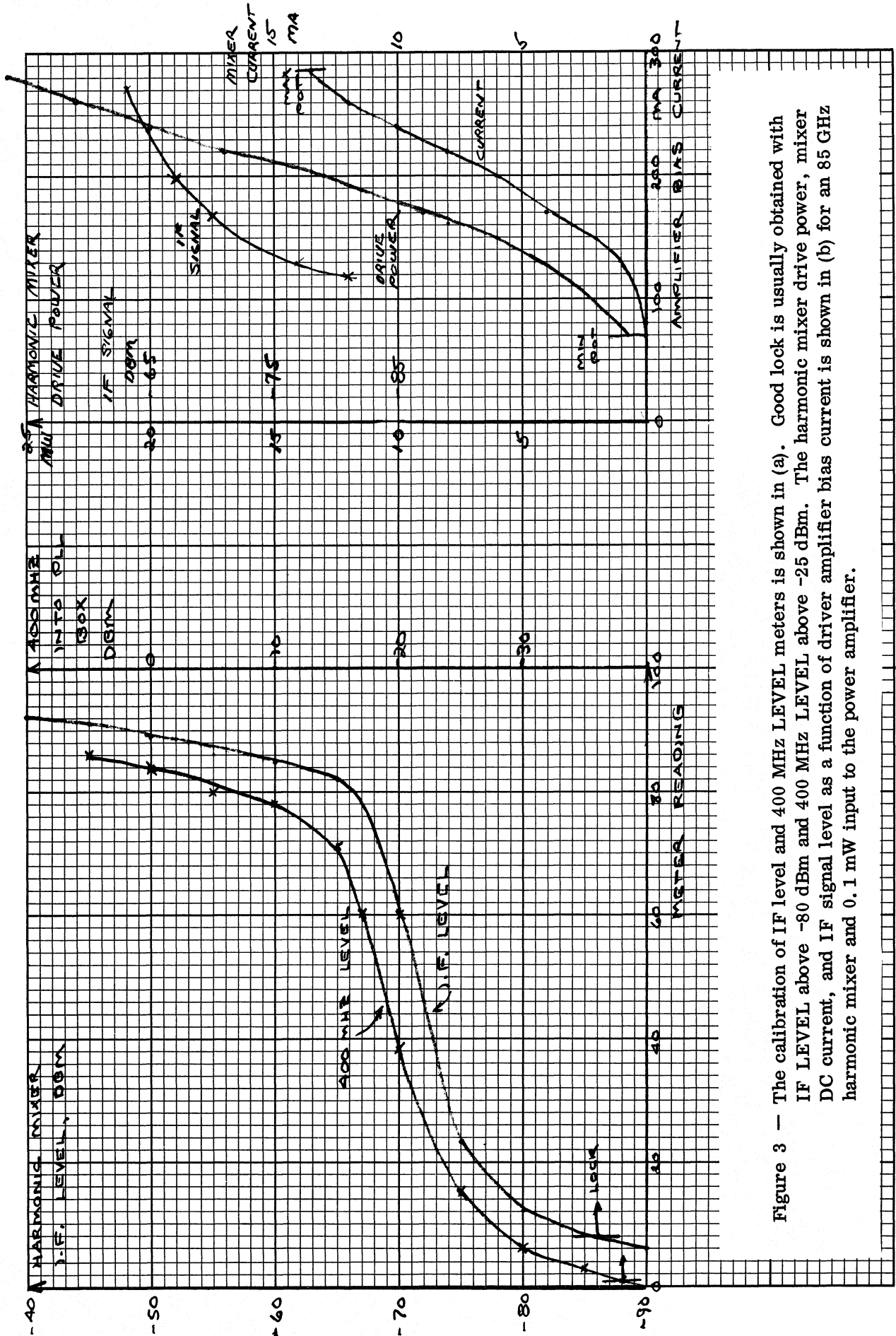

Figure 3 - The calibration of IF level and 400 MHz LEVEL meters is shown in (a). Good lock is usually obtained with IF LEVEL above -80 dBm and 400 MHz LEVEL above -25 dBm. The harmonic mixer drive power, mixer DC current, and IF signal level as a function of driver amplifier bias current is shown in (b) for an 85 GHz harmonic mixer and 0.1 mW input to the power amplifier.

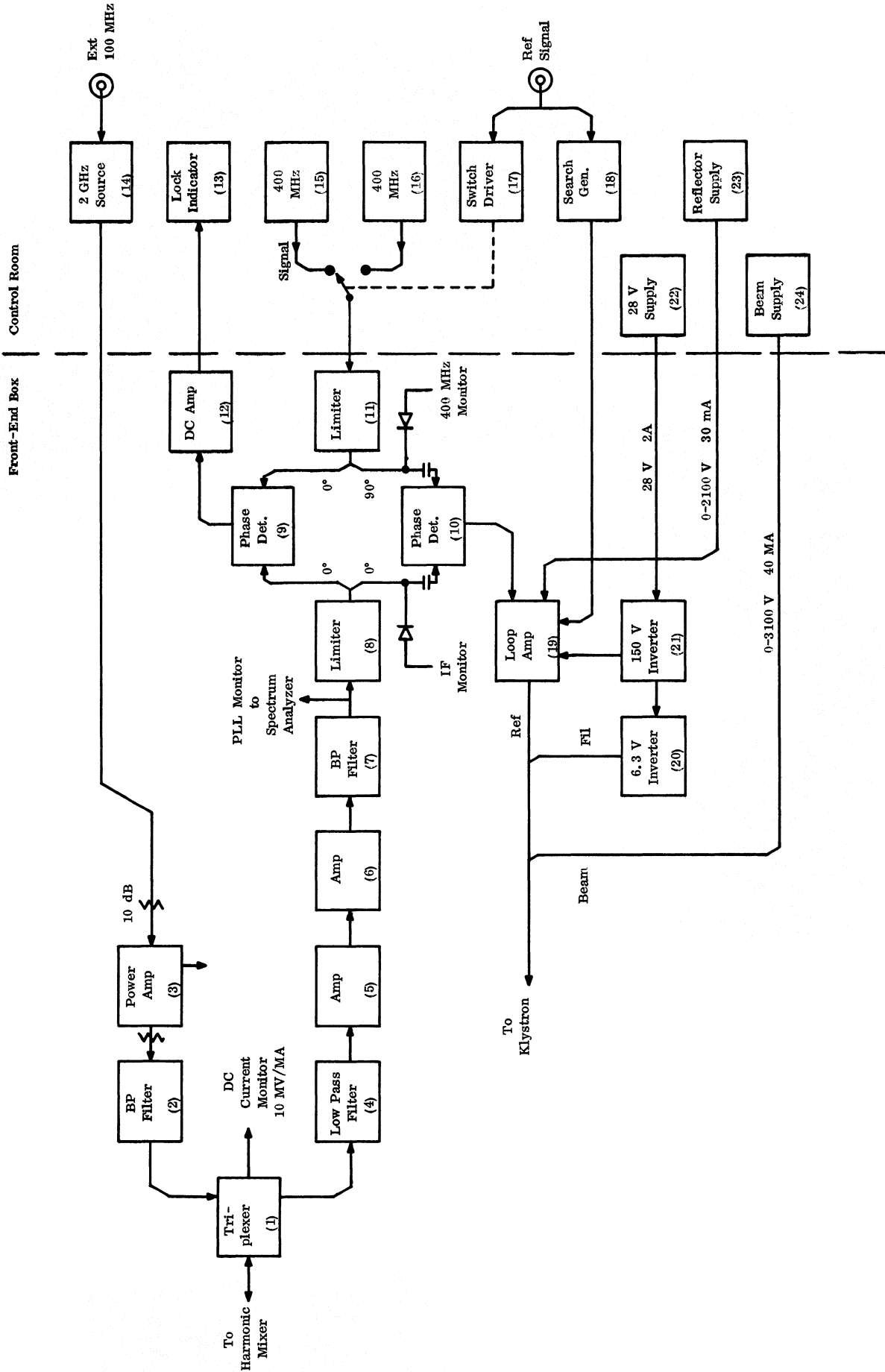

FIGURE 4 - PHASE-LOCK-LOOP BLOCK DIAGRAM

7315

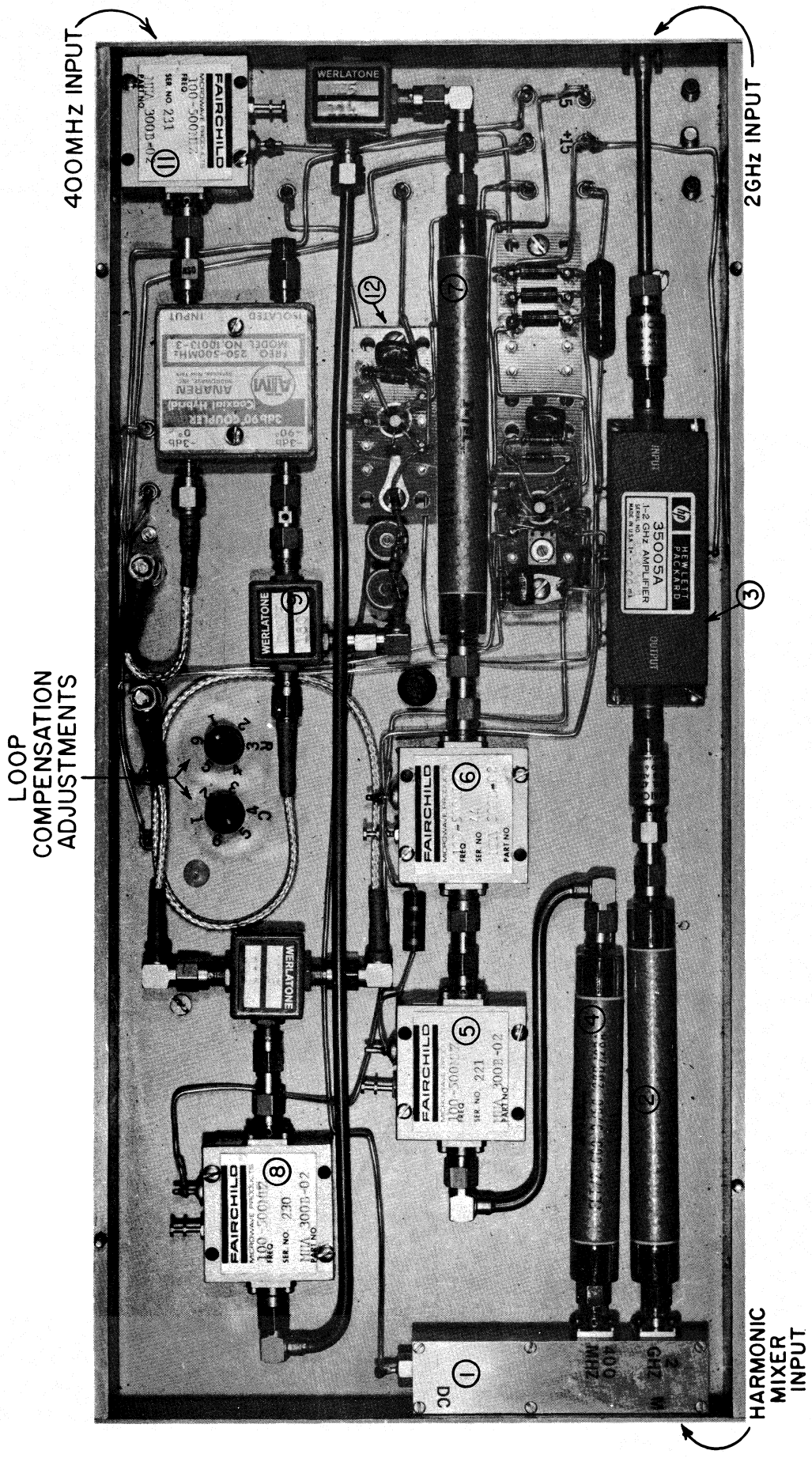

Figure 5(a) -- Phase-Lock Loop, Top Cover Removed. The component numbers refer to Figure 4 and the text. No high voltage is accessible in this compartment.

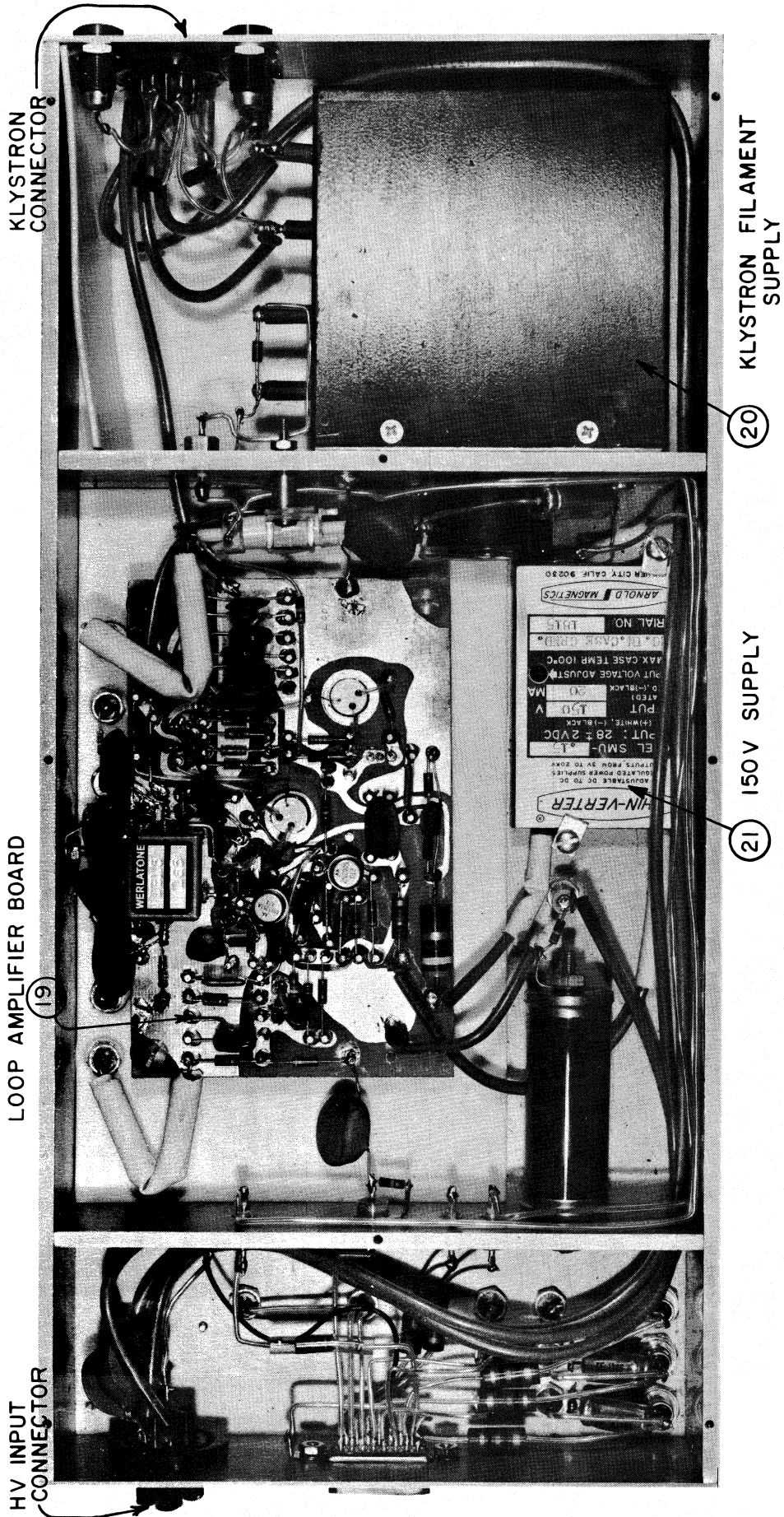

Figure 5(b) - Phase-Lock Loop, Bottom Cover Removed.
Caution: Lethal voltages exist in this compartment.

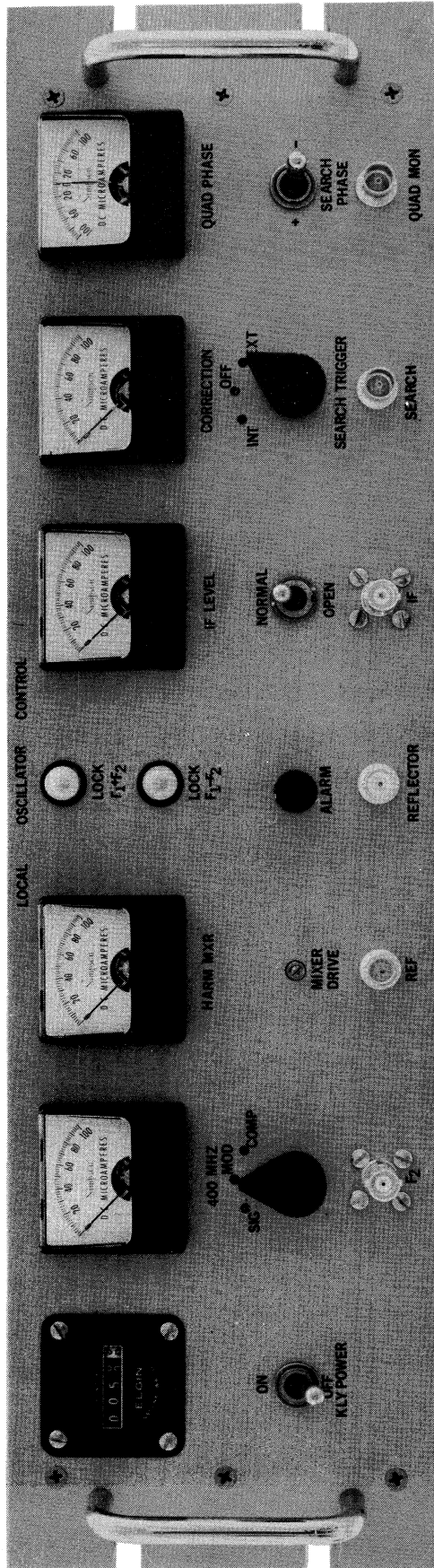
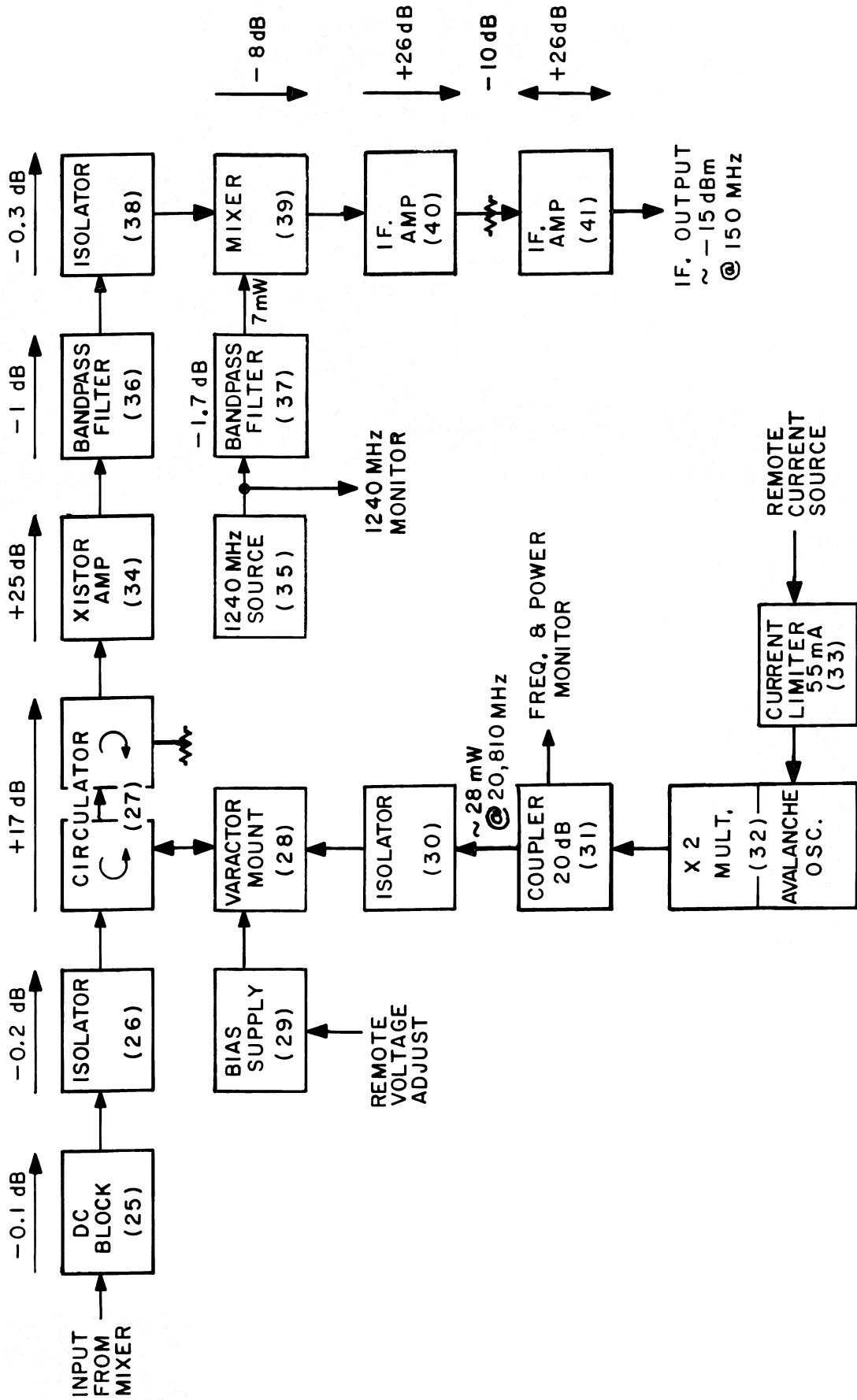

Figure 6 - Local Oscillator Stabilizer Control Panel.



IF. PORTION OF RECEIVER
BLOCK DIAGRAM

FIG. 7

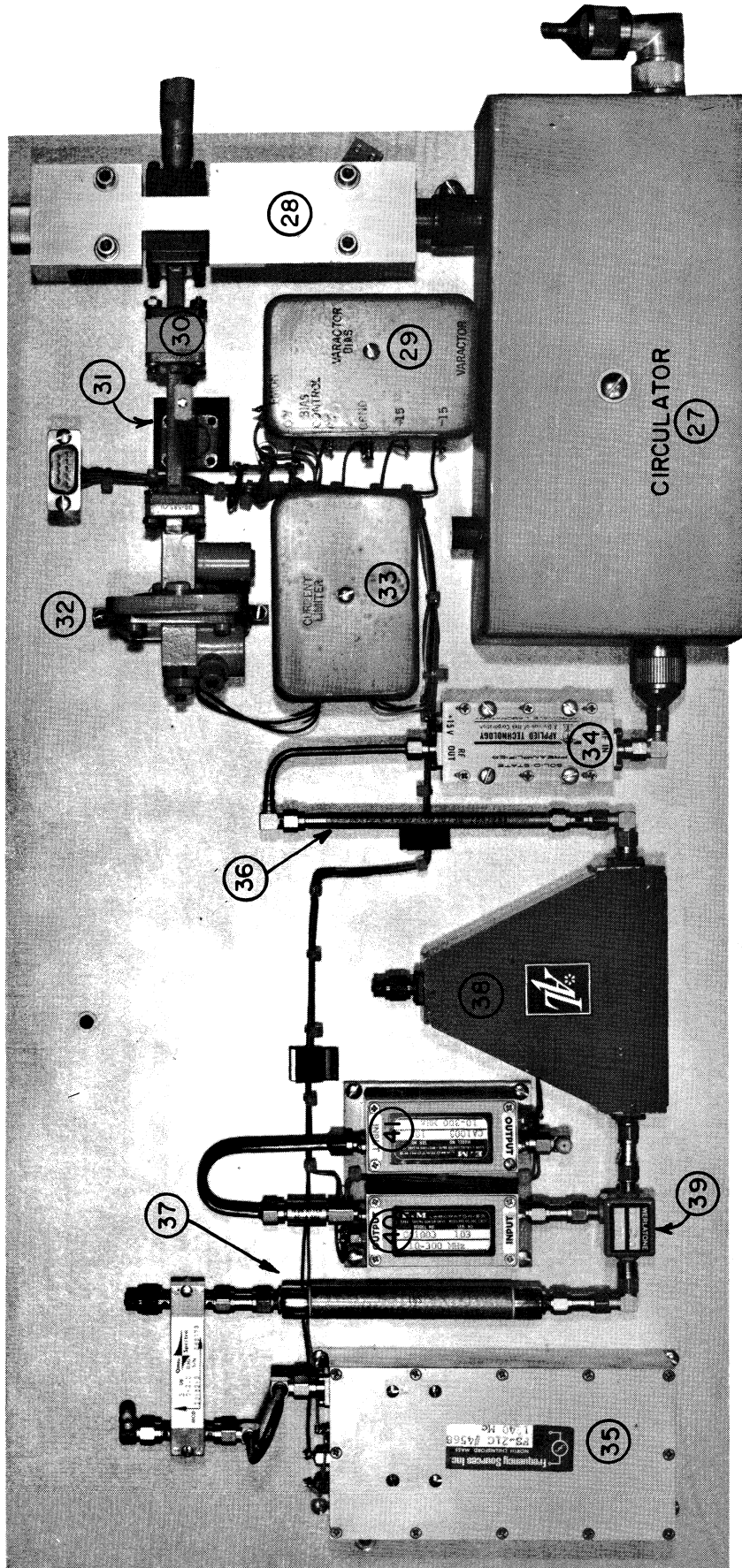

Figure 8 — IF Portion of Front-End Box.

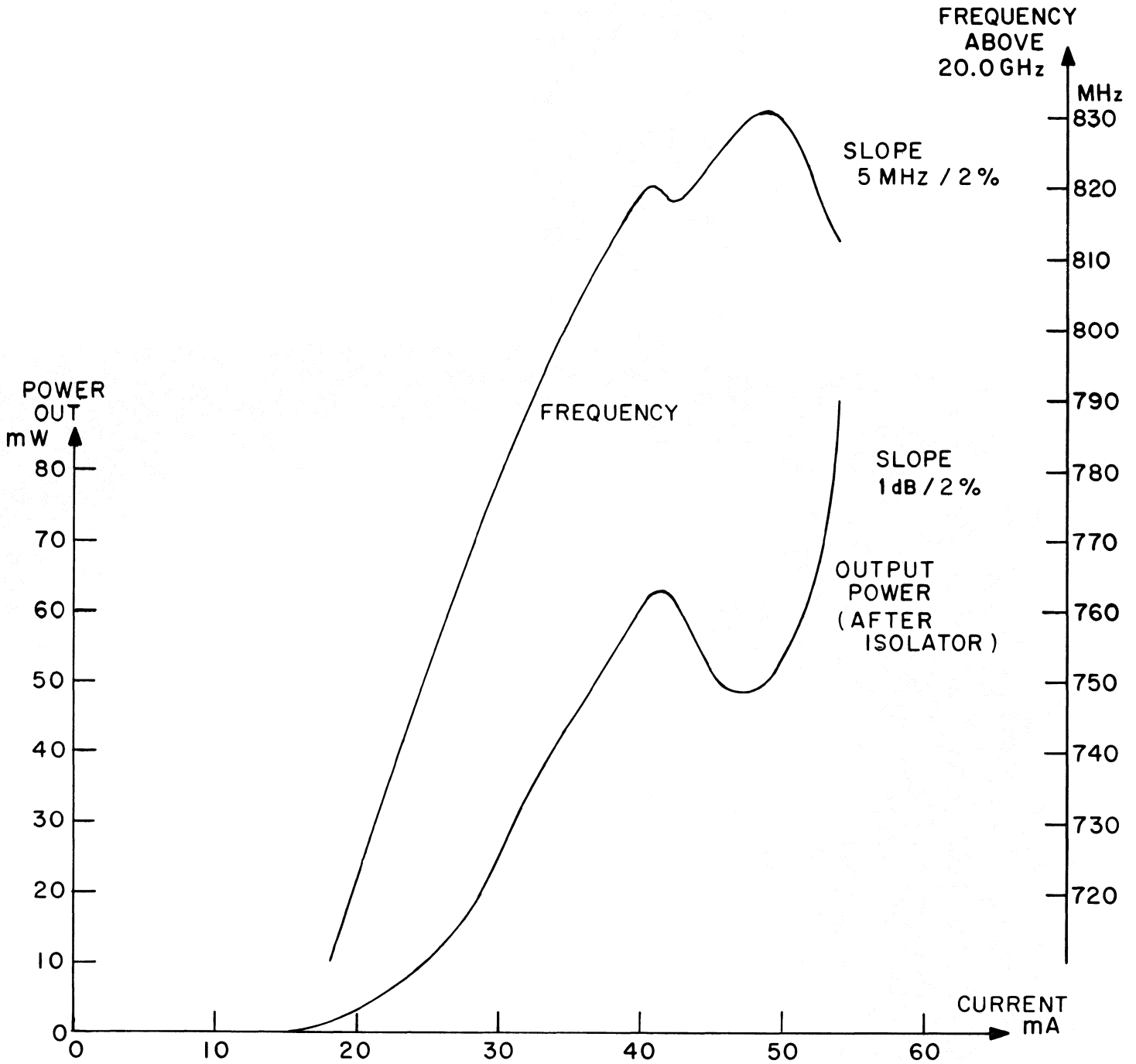

Figure 9 - Characteristics of Sylvania SYG-2030 Avalanche Diode Source No. 004

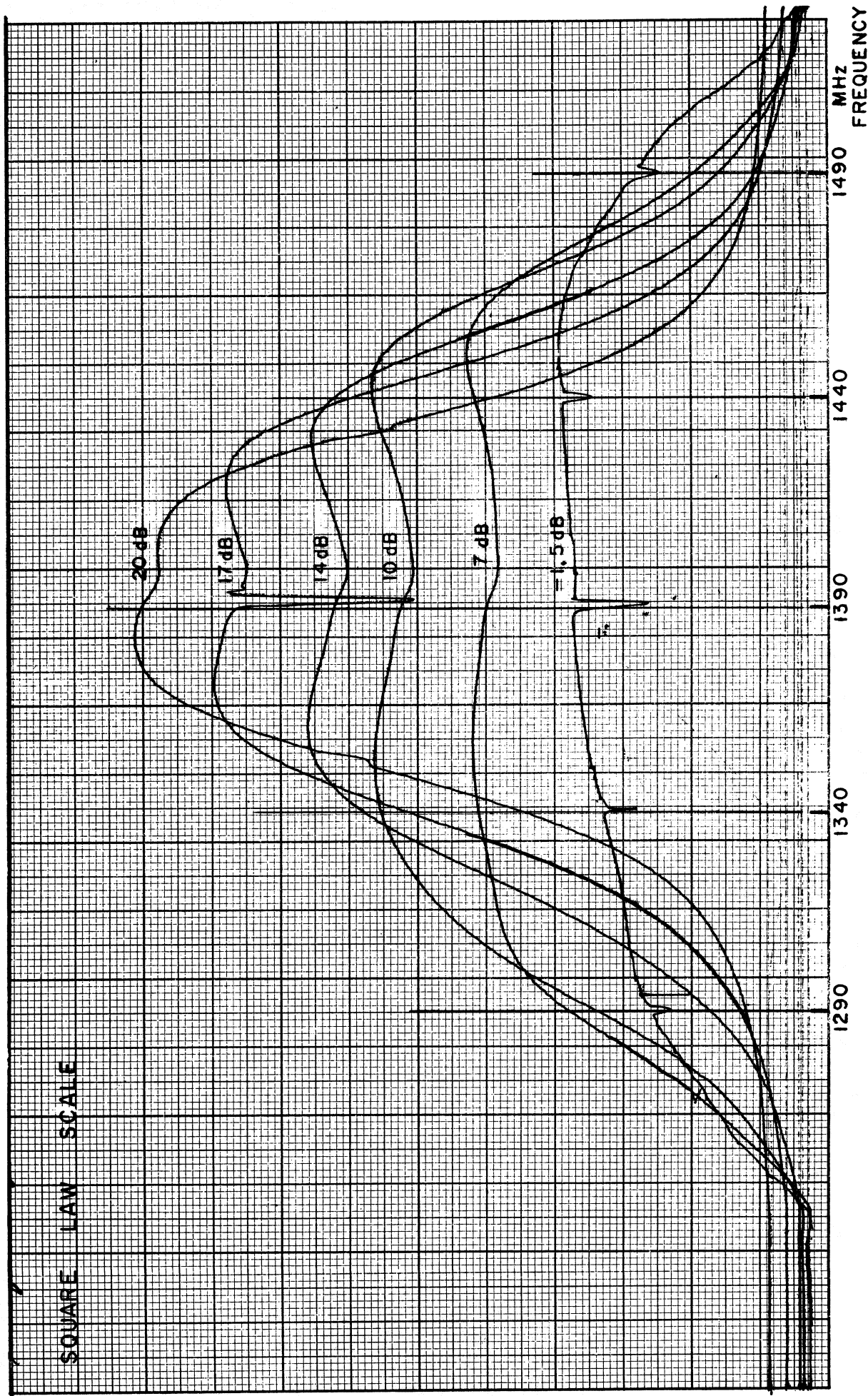
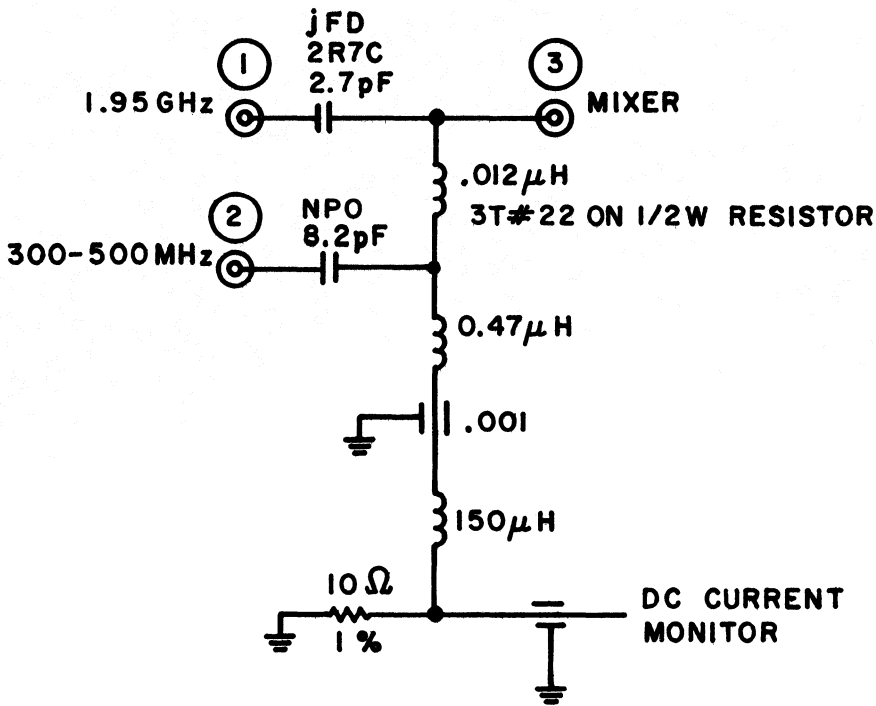
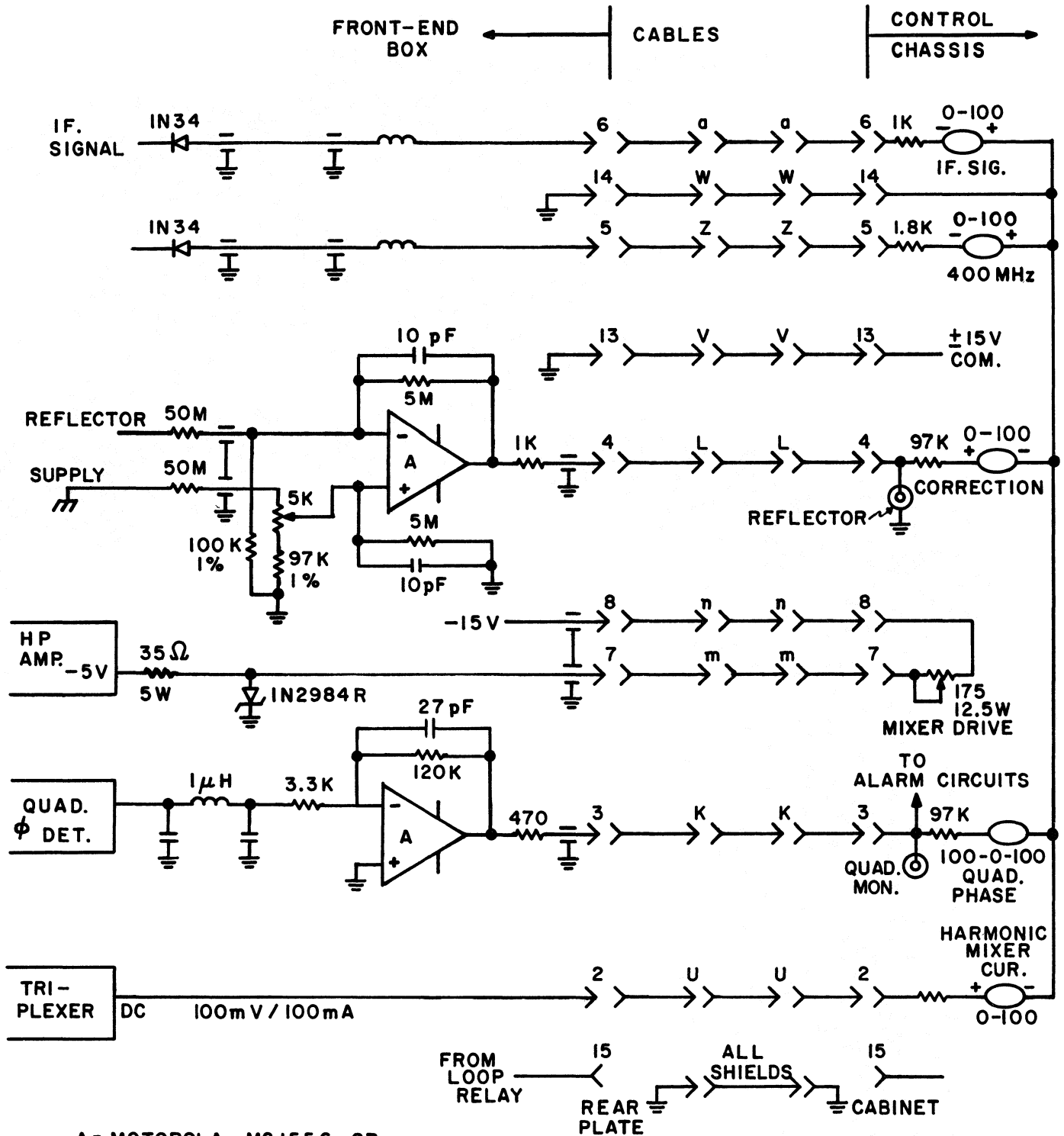

Figure 10 - Paramp Response at Various Gain Settings - March 7, 1970



MEASURED LOSS		
PORTS	FREQ.	LOSS
(1) - (3)	1.95	2.0 dB
(2) - (3)	0.4	0.7 dB

NATIONAL RADIO ASTRONOMY OBSERVATORY	
TITLE: TRIPLEXER FOR HARMONIC MIXER	
DSGN. BY: S. WEINREB	DATE: 8-70
APPD. BY:	DR. BY:
DWG. NO. S 2-547-1	



A = MOTOROLA MC1556 OR
ANALOG DEVICES AD741K

NATIONAL RADIO ASTRONOMY OBSERVATORY	
TITLE: PHASE-LOCK LOOP MONITOR WIRING	
DSGN. BY: SWEINREB	DATE: 8-31-70
APPD. BY:	DR. BY:
DWG. NO. S 2-547-2	

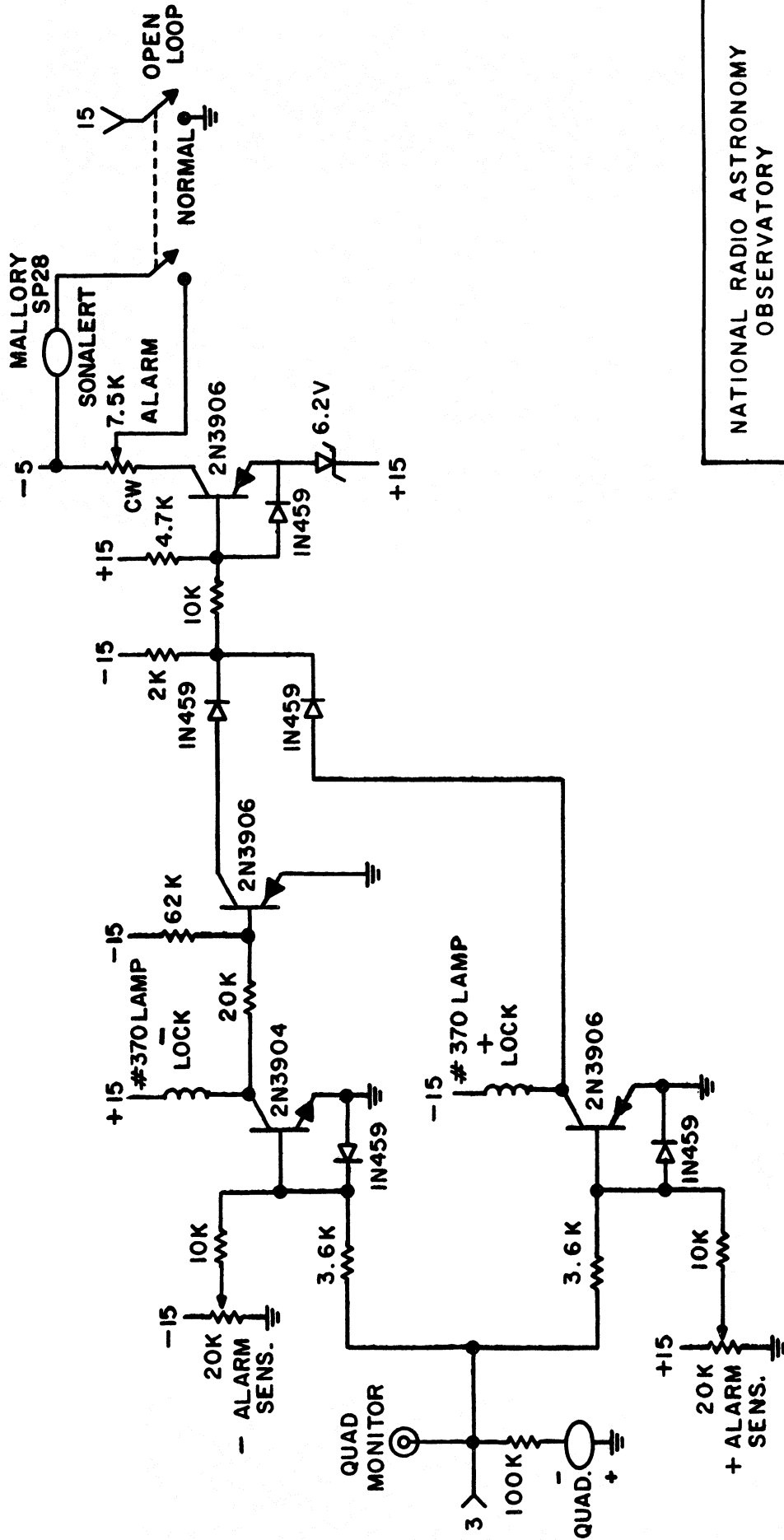

NATIONAL RADIO ASTRONOMY OBSERVATORY	
TITLE: LOCK INDICATION CIRCUITRY	
DSGN. BY: S. WEINREB	DATE: 8-28-70
APPD. BY:	DR. BY:
DWG. NO. S 2-547-3	

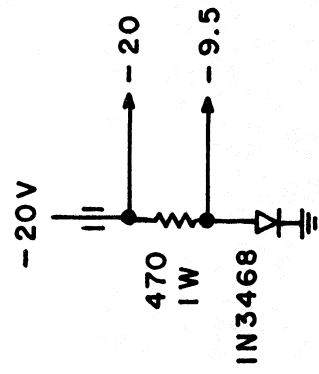
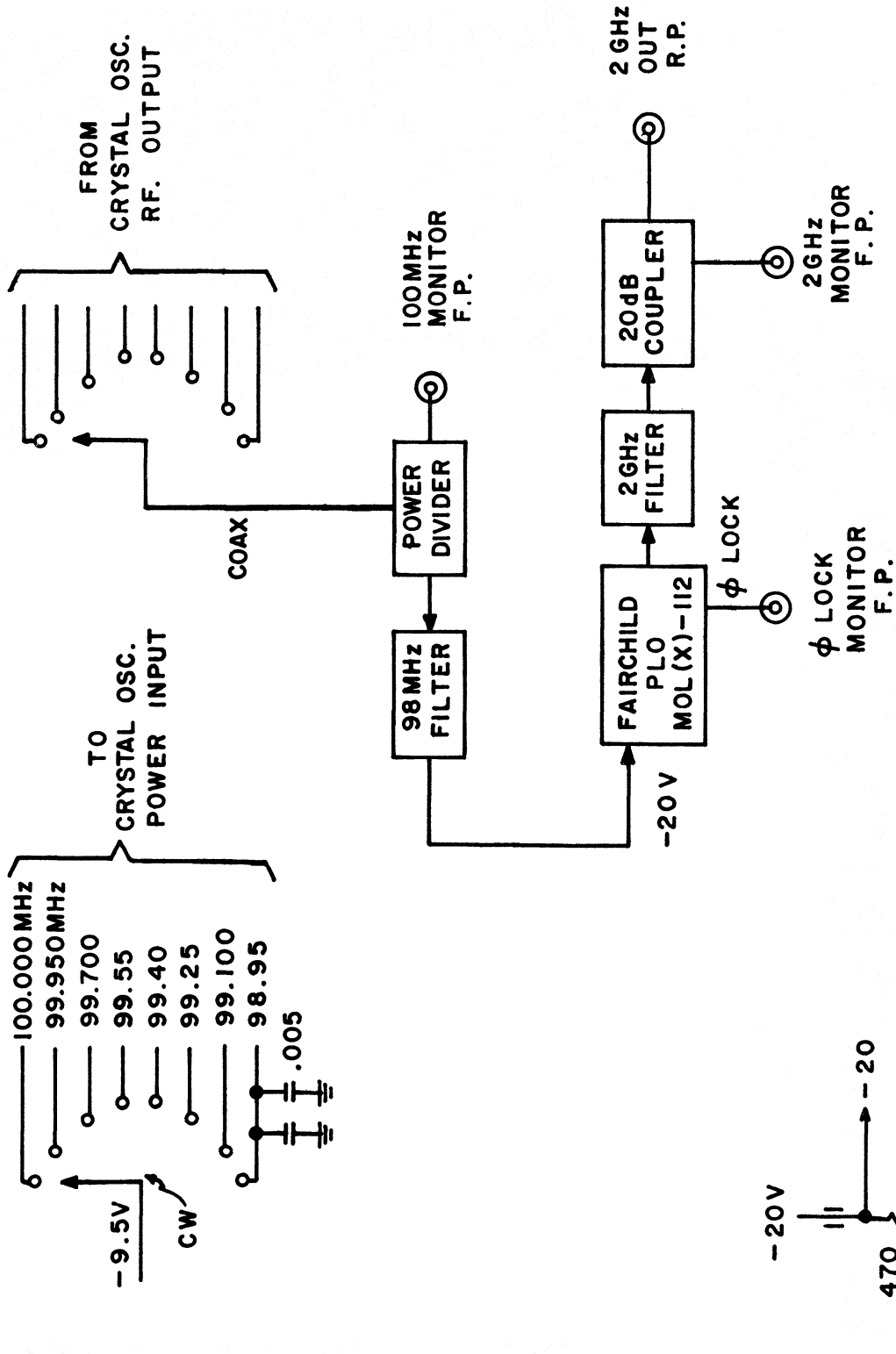

NATIONAL RADIO ASTRONOMY OBSERVATORY	
TITLE: 2 GHz LO. REFERENCE UNIT	
CSGN. BY: S. WEINREB	DATE: 8-70
APPD. BY:	DR. BY:
DWG. NO. S 2-547-4	

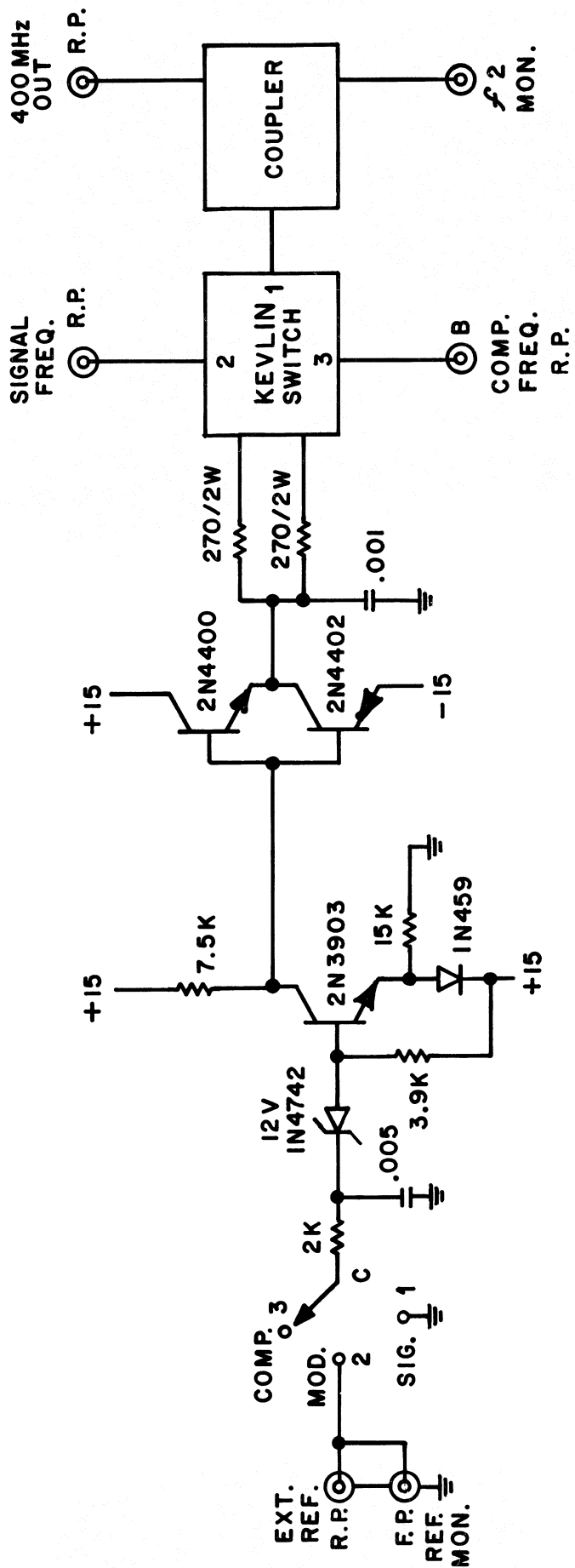

NATIONAL RADIO ASTRONOMY OBSERVATORY	
TITLE: SWITCH DRIVER	
DSGN. BY: S. WEINREB	DATE: 8-70
APPD. BY:	DR. BY:
DWG. NO. S-2-547-5	

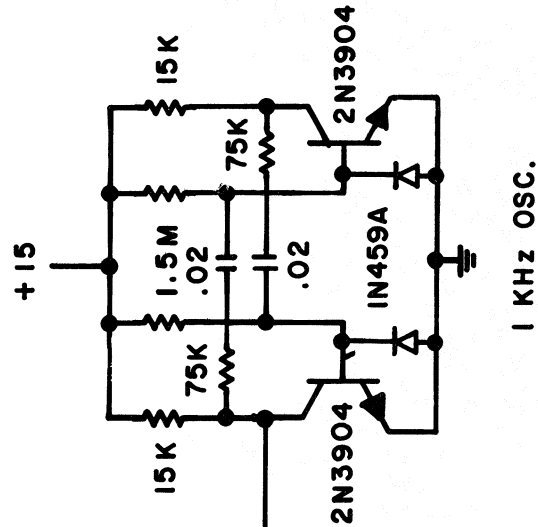
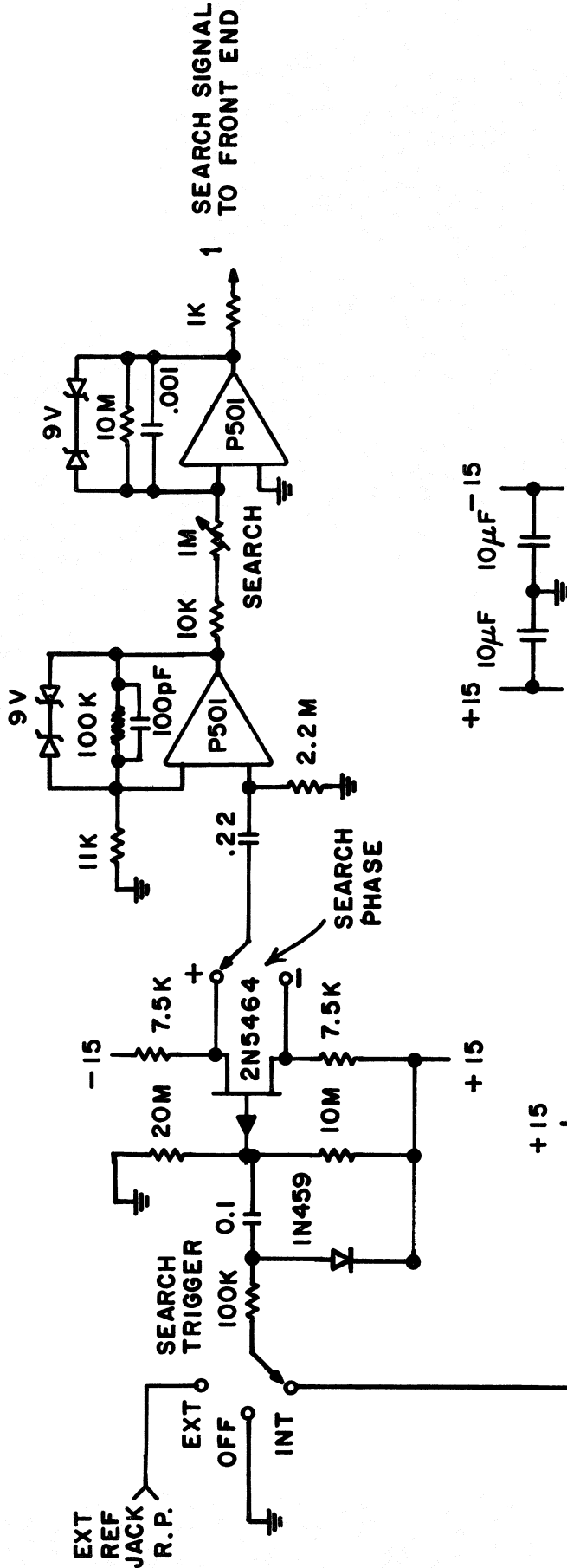

NATIONAL RADIO ASTRONOMY OBSERVATORY	
TITLE: SEARCH SIGNAL GENERATOR	
DSGN. BY: S. WEINREB	DATE: 8-70
APPD. BY:	DR. BY:
DWG. NO. S 2-547-6	

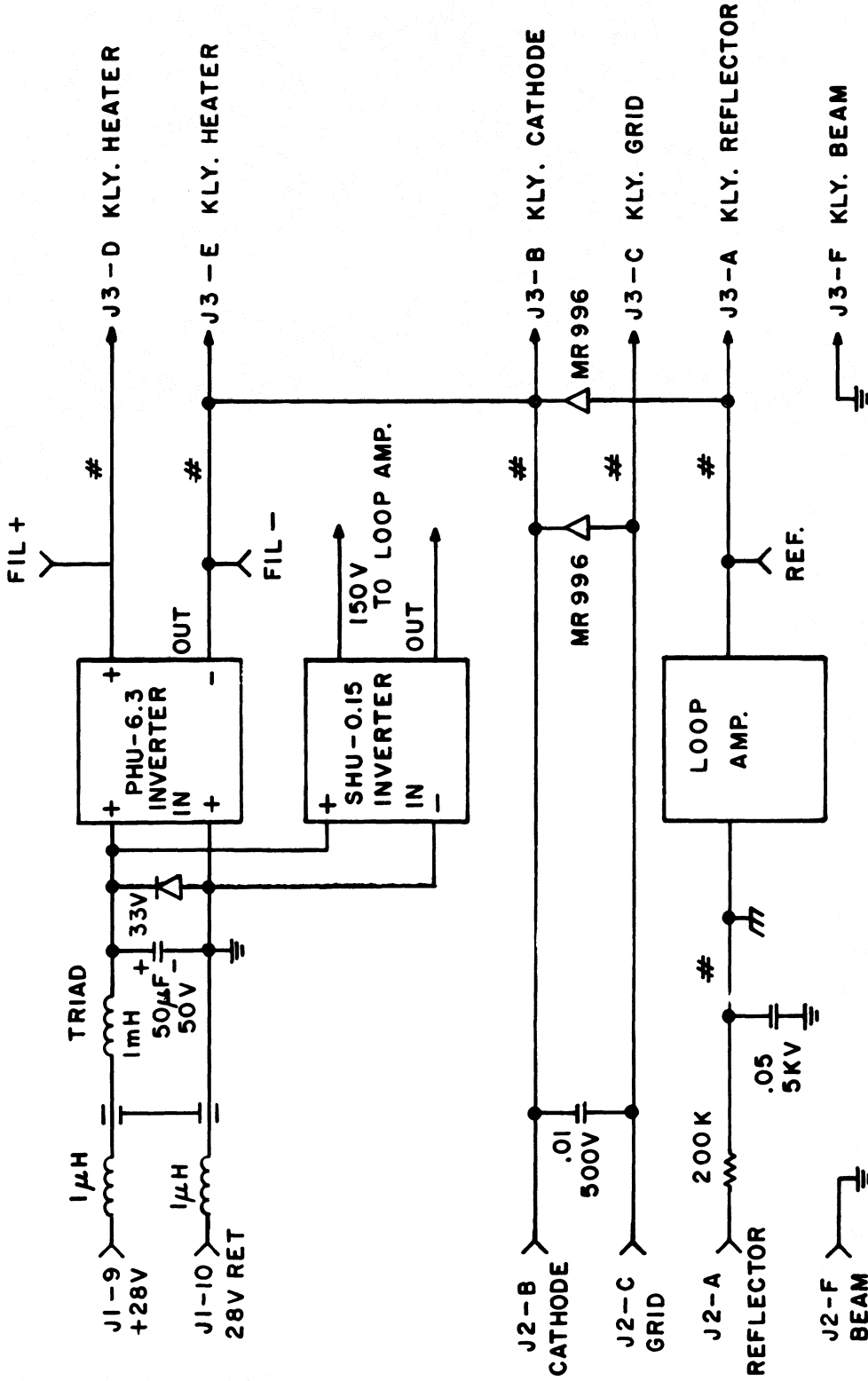

= "LOSSYLINE CABLE"

NATIONAL RADIO ASTRONOMY OBSERVATORY	
TITLE: PHASE-LOCK LOOP POWER WIRING	
DSGN. BY: S. WEINREB	DATE: 7-22-70
APPD. BY:	DR. BY:
DWG. NO.: S 2-547-8	

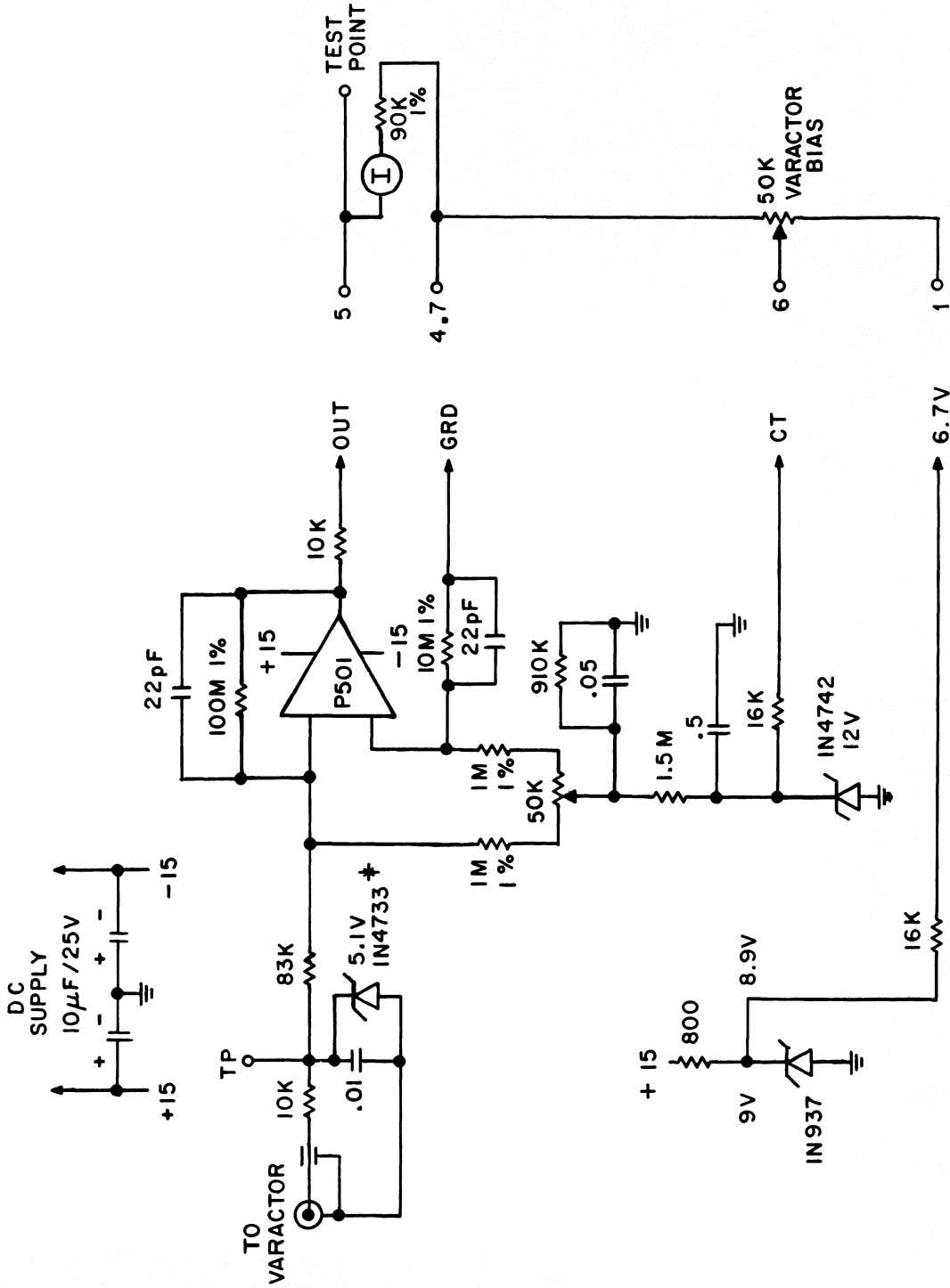

* SELECT FOR LEAKAGE CURRENT < 2µA AT 2V.

NATIONAL RADIO ASTRONOMY OBSERVATORY	
TITLE: VARACTOR BIAS SUPPLY & MONITOR	
DSGN. BY: S. WEINREB	DATE: 2-2-70
APPD. BY:	DR. BY: A. M.
DWG. NO. S 2-547-9	

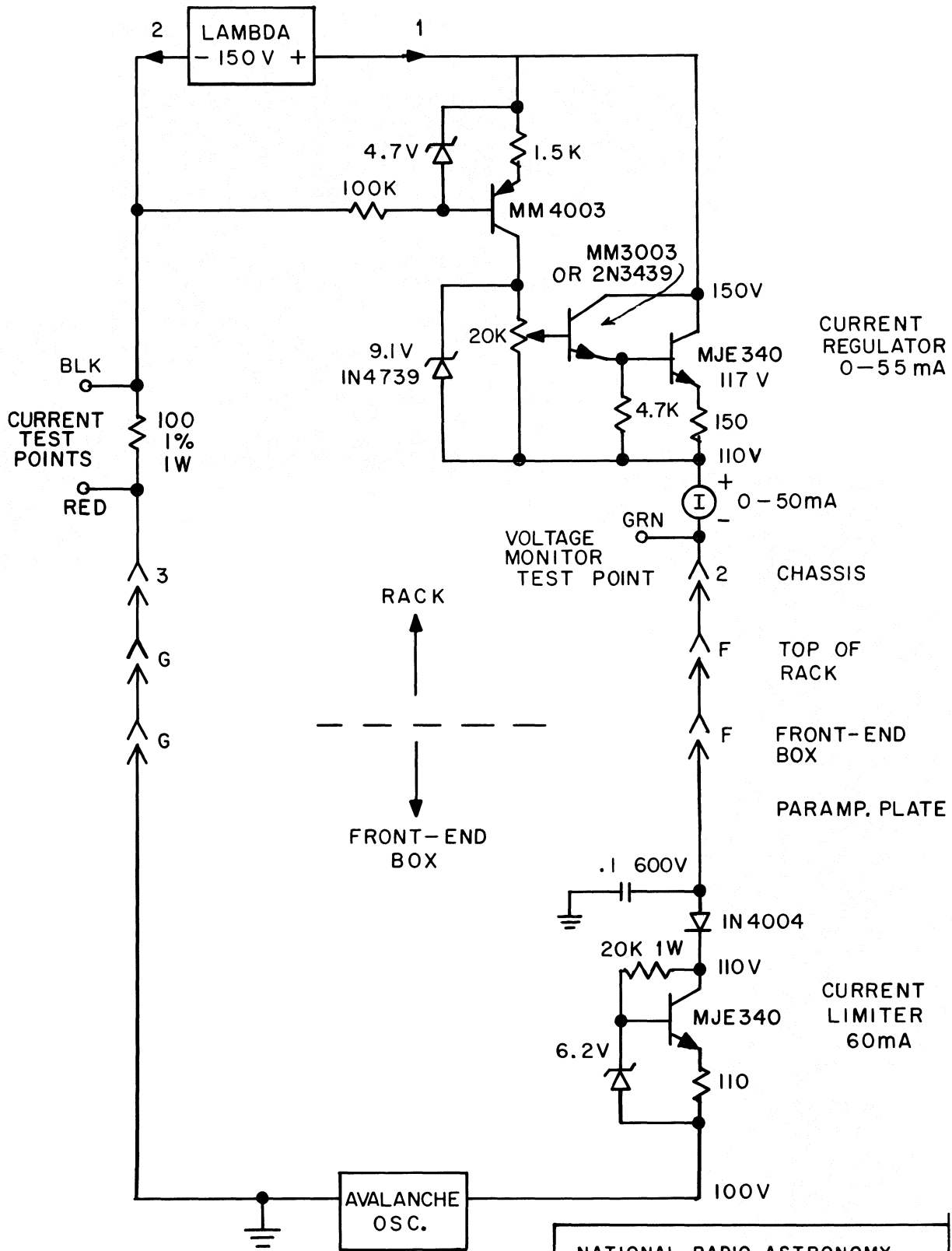

NATIONAL RADIO ASTRONOMY OBSERVATORY	
TITLE: AVALANCHE DIODE POWER SUPPLY	
DSGN. BY: S. WEINREB	DATE: 3-4-70
APPD. BY:	DR. BY: A.M.
DWG. NO. S2-547-10	

CABLE RECORD

General Location: Telescope Cable - 15 Pair

From: Front-End

Connector: QWL 81-194236-10S

To: Control Room

Cable Identification: 15 Pair

From Pin	Cond. Color	To Pin	Purpose
A	Red	A	+15 V
B	Yellow	B	-15 V (not return for +15 V)
E	Shield	E	
C	Red	C	Varactor Current Monitor 1 V/100 nA
D	Yellow	D	Paramp Bias Voltage Pot - CW
J	Shield	J	
O	Red	O	Varactor Bias Pot - CT
P	Yellow	P	Bias Pot - Gnd
F	Red	F	+150 - Avalanche Osc.
G	Yellow	G	150 Return - Avalanche Osc.
T	Red	T	PLL - Search
U	Yellow	U	PLL - Harmonic Mixer Current
K	Red	K	PLL - Quad Phase
L	Yellow	L	PLL - Correction V.
Z	Red	Z	PLL - 400 MHz Level
a	Yellow	a	PLL - IF Ref.
V	Red	V	Box Gnd ± 15 V Return
W	Yellow	W	Box Gnd
m	Red	m	PLL - 2 GHz Amp. Bias
n	Yellow	n	-15 V for above
b	Red	b	Open Loop Relay
c	Yellow	c	Gnd
r	Red	r	Mixer Current - Terminal strip near RF section
s	Yellow	s	Mixer Return
t	Red	t	Spare
u	Yellow	u	
f	Red	f	Spare
g	Yellow	g	
h	Red	h	Spare
j	Yellow	j	
			+15 V 1
			-15 V 2
			Return 3

CABLE RECORD

General Location: Front-End Box

From: Phase-Lock Loop Box

Connector: DAM-15S

To: Rear Plate

Connector: 15 Pair and 30 Conductor

Type: 7 Pair

From Pin	Cond. Color	To Pin	Purpose
T } U }	Black	1	Search
	Brown	2	Harmonic Mixer Current
K } L }	Red	3	Quad Phase
	Orange	4	Corr Volt
Z } a }	Yellow	5	400 MHz
	Green	6	IF Level
m } n }	Blue	7	2 GHz Bias
	Violet	8	-15 for 2 GHz
30 Cond. A and B }	Red	9	+28 V
30 Cond. C and D }	White	10	28 V Return
A } B }	White/Red	11	+15 V
	White/Blue	12	-15 V
V } W }	White/Orange	13	± 15 V Return
	Grey	14	Quality Gnd
b	White	15	Open Loop Relay

CABLE RECORD

General Location: Front-End Box - Near RF Section

From: RF Section

Connector: 14S - 6S MS Connector

To: Rear Plate

Connector: 30 Conductor

From Pin	Cond. Color	To Pin	Purpose
A		G	Ferrite Modulator
B		H	Ferrite Modulator
C		J	Spare
D		P	Spare
E		S	117 V AC (Fan)
F		T	117 V AC