

NATIONAL RADIO ASTRONOMY OBSERVATORY
Green Bank, West Virginia

Electronics Division Internal Report No. 89

GENERAL DESCRIPTION AND OPERATING
INSTRUCTIONS FOR THE
WATER VAPOR RECEIVER

James L. Dolan

JANUARY 1970

NUMBER OF COPIES: 100

GENERAL DESCRIPTION AND OPERATING INSTRUCTIONS
FOR THE WATER VAPOR RECEIVER

James L. Dolan

In an attempt to correlate water vapor density and interferometer phase changes, radiometers to measure water vapor in the atmosphere have been designed and constructed. Units 1 and 2 have been built and installed on the 85-1 and 85-2 telescopes. A general description of the system will be given along with operating instructions. Reference will be made to the block diagrams.

Theory

It is known that water vapor causes phase delays to microwave signals propagating through it. These effects of water vapor extend over many wavelengths. Although the thermal emission from water vapor molecules is centered at $\lambda = 1.35$ (22.235 MHz), the emission is smeared and may be observed over a wide range of frequencies. The radiometers described in this note are designed to measure the differential water vapor in two (or more) non-overlapping paths. The radiometers are switched frequency types, as opposed to switched load, although it is possible to use them as switch load systems. One frequency, 23.3 GHz, is positioned near the peak of the thermal emission curve. This frequency is referred to as the "signal" frequency. The other frequency, 20.3 GHz, is positioned at a lower point on the curve and is referred to as the "comparison" or "reference" frequency. The differential water vapor can be measured in the following manner:

The overall system temperature at 20.3 GHz (F_1) is given by

$$T_{S_1} = T_R + T_A \quad (1)$$

where T_{S_1} = overall system temperature at F_1

T_R = radiometer temperature

T_A = antenna temperature.

The overall system temperature at 23.3 GHz (F_2) is given by

$$T_{S_2} = T_R + T_A + T_W \quad (2)$$

where T_{S_2} = overall system temperature at F_2

T_W = fraction of antenna temperature caused by water vapor emission.

(It should be noted that all temperatures referred to here are equivalent temperatures.)

It follows that

$$T_{S_2} - T_{S_1} = T_W \quad (3)$$

With two radiometers we can measure

$$T_{W_1} - T_{W_2} = \Delta T_W \quad (4)$$

the differential temperature caused by water vapor in the two paths. By observing phase changes, $\Delta\phi$, in the interferometer fringes from a reference source and comparing $\Delta\phi$ to ΔT_W , a correlation may be found (providing the observed phase delays are actually caused by water vapor). If phase changes can be correlated with differential water vapor information, the knowledge could be usefully applied to large synthesized arrays.

Reference 1 — Joe W. Waters, VLA Scientific Memorandum No. 8, September 14, 1967, "Atmospheric Effects on Radio Wave Phase and the Correction of Vapor-Caused Phase Fluctuations by Radiometric Measurements of Water Vapor Emission."

Front-End Description

Refer to block diagram B2.502-1. The antenna used for the system is a 3-foot parabola covering the general frequency band of 18 to 26 GHz (K band). K-band waveguide is used for all the signal and local oscillator circuits. When the system is being used as a water vapor detector system the Dicke switch is locked to the antenna position and the local oscillator is switched between 20.3 GHz and 23.3 GHz. Physically, two oscillators are used, switched on and off by a DC voltage in phase with the synchronous detector. It is also possible to lock either of the oscillators on for continuum use if that mode is desired. Calibration is accomplished by a K-band argon excess noise diode. In the frequency switching mode it is necessary to modulate the noise diode for calibration. This is accomplished by leaving the noise tube on and switching the output on and off by means of a ferrite switch. The calibration mark on units 1 and 2 has been adjusted to 60 ± 2 °K.

Signal Tracing

The wideband signal from the antenna is routed through the crossguide coupler (used for calibration signal insertion) through the ferrite switch (normally locked to the antenna input) and then through the isolator to the balanced mixer-preamp circuit. Here the signal is mixed with the local oscillator signal to the intermediate frequency of $160 \text{ MHz} \pm 140 \text{ MHz}$, for a total IF bandwidth of 280 MHz. The local oscillator signal is derived in the following manner.

Two Gunn effect oscillators are used, oscillating at 20.3 GHz (F_1) and 23.3 GHz (F_2), respectively. The oscillators are turned on and off by the synchronizing drive voltage at a switch rate of 10 Hz. Switching voltage is symmetrical, making the duty cycle for each oscillator 50 percent. (In continuum mode, one oscillator is used 100 percent.) From the Gunn oscillators the signal is routed through level adjusting attenuators to an isolator and finally to the local oscillator (LO) input on the balanced mixer. The mixer crystal current is sampled and the amplified error signal is fed back to the current controlled attenuator to keep the LO power level constant while switching between F_1 and F_2 . Because there are no frequency discriminating components ahead of the mixer, this is a double sideband system, center signal frequencies being $20.3 \pm 160 \text{ MHz}$ and $23.3 \pm 160 \text{ MHz}$, the bandwidth at each frequency being equal

to the IF bandwidth of 280 MHz. (See Figure 1 for a pictorial presentation of RF signal bands.) From the double sideband balanced mixer-preamp the IF signal is further amplified by a wideband transistor amplifier and then detected (demodulated) by a square law detector. The video or varying DC signal is then amplified and synchronously detected by a standard NRAO standard receiver unit. (See Standard Receiver Instruction Manual, August 1967.) The output of the synchronous detector is the signal T_W referred to in the "Theory" section. This signal is sampled and recorded on magnetic tape for further analysis.

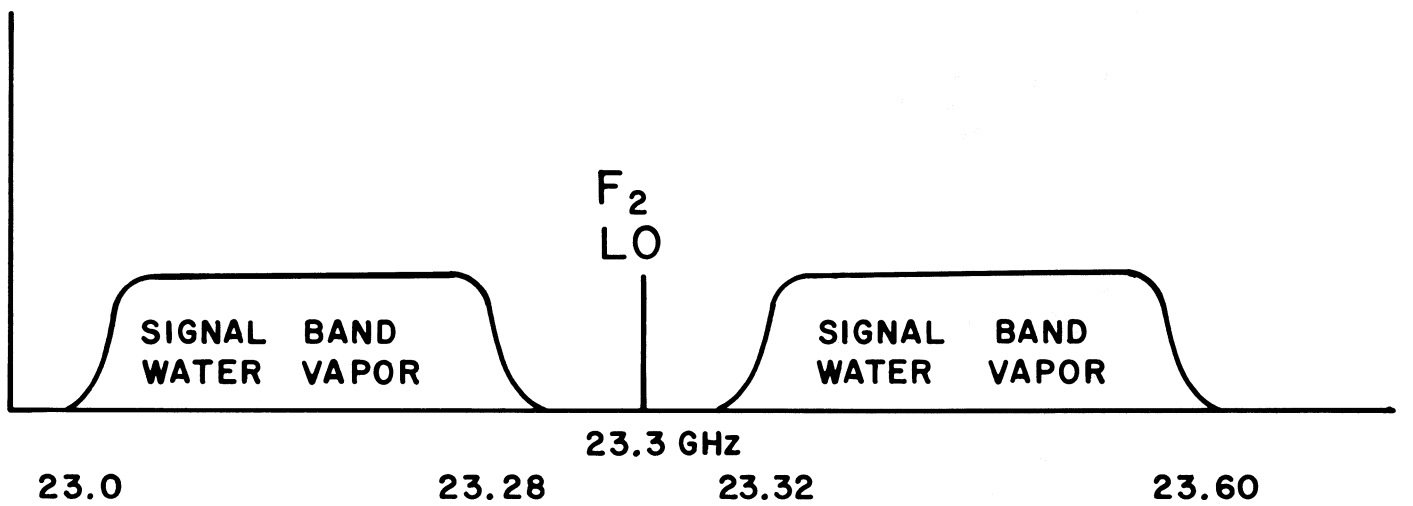
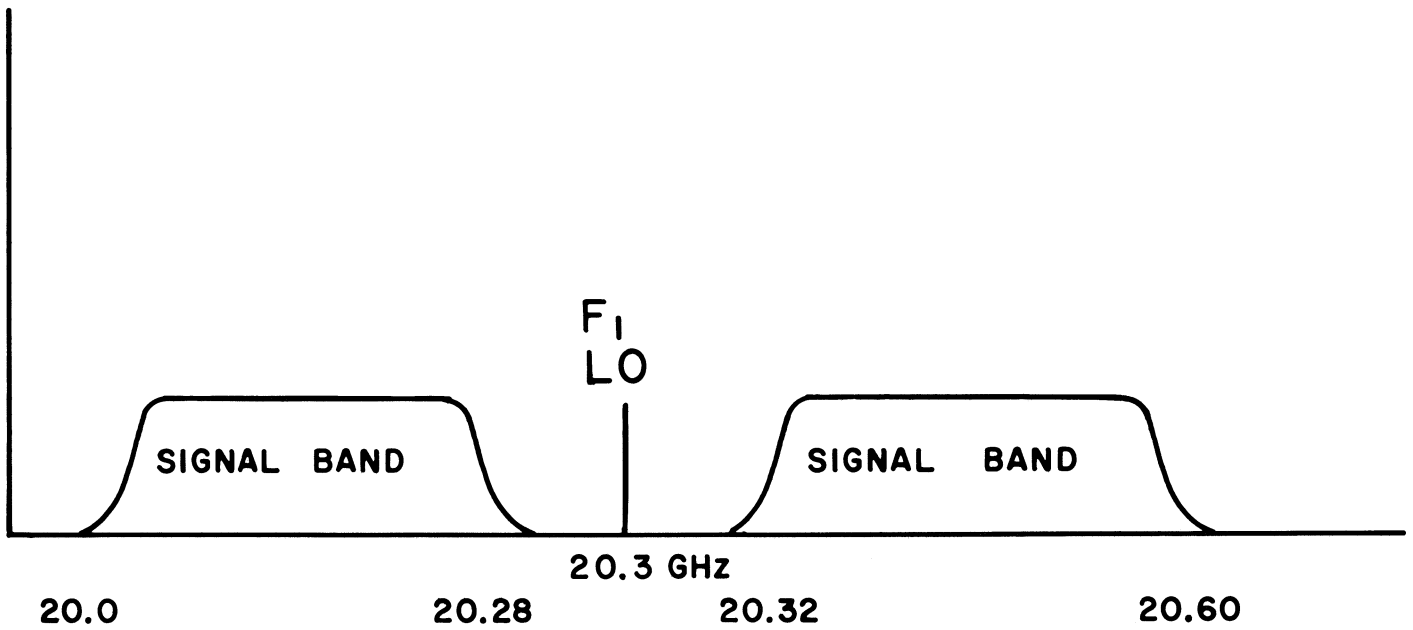

RF SIGNAL BANDS FOR THE
WATER VAPOR RADIOMETERS
FIG.1

Control Functions and Operating Instructions

A brief description of the purpose of the front panel controls and normal settings will be given. There are no operator controls on the front-end enclosure — any adjustments required in the RF system normally require experienced personnel and laboratory equipment. The control panel is located in each telescope control room in an accessible place. This description is for unit 1. However, the units are practically identical and the instructions apply to both units.

Control	Function
NT On-Off	Fires the argon excess noise diode. The "NT Current" meter should read 175 mA when the noise diode is "on".
CAL-LO	Places the "Atten Current" meter in the calibration injection current-controlled attenuator circuit or in the LO leveler circuit. In the "LO" position the meter should read up scale indicating enough power for proper leveling action. In the "Cal" position the reading depends on the cal mode switch. With the cal mode "Off" the meter reads approximately 155 mA. With the cal mode "On" the meter reads 0. With the cal mode switch on "Mod" the meter reads approximately 75 mA.
XTAL 1, 2	Places the xtal current meter in either of the balanced mixer crystal circuits. Normal reading for both crystals is about 0.7 to 1.0 mA.
NOISE TUBE CURRENT ADJUST	Used to set noise tube current to 175 mA. Seldom needs attention.
REFERENCE FREQUENCY	Selects reference generator switch rate. Should not be set faster than 10 Hz in the frequency switching mode.
CAL "ON", "MOD", "OFF"	See "Cal-LO".
LO - HI - MOD - LOW	Selects either 23.3 GHz (Hi) or 20.3 GHz (Low) or switches between the two frequencies (Mod). Normally set on "Mod".

Continued --

Control	Function
DICKE SWITCH SIG-MOD-COMP	Used mostly for laboratory testing and calibration. Locks the front-end switch to the antenna ("Sig") or a comparison termination ("Comp") or switches between the two ("Mod"). For water vapor work, normal setting is on "Sig".
TOTAL POWER - SW. POWER	Selects the meter scale in volts for either total power or switched output. Normally set to sw. power, 1 volt.
GAIN RATIO - "ON - OFF"	The "On-Off" switch puts the post-detection gain modulator in or out of the circuit. The ten turn dial adjusts balance.
INPUT LEVEL	DC gain adjust. Can be used to adjust full scale temperature readings to proper level. Does not need regular attention.
FULL SCALE TEMP	AC gain control normal setting is marked (usually 100°).
TIME CONSTANT	Selects RC time integration. Normally set to 1 or 10 sec.
SW (BNC JACK)	Presents radiometer output to front panel.
TP (BNC JACK)	Presents radiometer post-detection signal to front panel.

FRONT-END PARTS ONLY — WATER VAPOR RECEIVER PARTS LIST

Component	Manufacturer	Model	Price	Comment
Antenna	TRG	---	\$ 1,000	---
Waveguide section (flex.)	Airtron	AF-3-B-042-600	28	---
Bends, E-Plane 90°	Waveline	832-2 (\$35)	245	7 required
Bends, H-Plane 90°	Waveline	833-2 (\$35)	70	2 required
Coupler crossguide	Waveline	870-20	115	---
Termination	Waveline	854 (\$35)	70	2 required
Ferrite switch	E&M	K111LTS	950	---
Isolator	E&M	K854LI (\$250)	500	2 required - 20.23-24.23 GHz
Current cont. atten.	E&M	K126VAM	400	---
Ferrite switch	E&M	K122VAM	400	20-23 GHz
Attenuator	Waveline	813	100	---
Attenuator	TRG	K513-17	145	---
Attenuator	TRG	K513-14	145	---
Waveguide 90° twist	Waveline	890-2	55	---
Hybrid	Waveline	858	110	---
Waveguide section	Waveline	842	25	---
Noise tube mount	Waveline	22008	225	---
Detector mount	Waveline	816	70	---
Frequency meter	FXR	K410AF	280	---
Signal source	Varian	VSK9008C	695	---
Signal source	Varian	VSK9008B	695	---
Pad	Texscan	FP-50	16	---
Mixer amplifier	Space-General	9126R-1	7,450	Price quoted for 2 mixers
Amplifier	C-COR	3596	185	---
Power supply	Acopian	6S50	90	---
Power supply	Acopian	15D20D-15D20D	120	---
Assorted circuits	NRAO	---	500	(Misc.)

Total \$14,704

Acknowledgments

This project was initiated in 1967 under the direction of Dr. Sander Weinreb. Many people contributed their particular specialties to the project. I will list as many as I can remember, or find record of, along with their part in the successful completion of the two operating systems.

S. Weinreb	Initial conception and design.
*K. Wesseling	Preliminary research.
*J. Waters	Preliminary research.
*D. Logan	Initial procurement.
*D. L. Thacker	System construction supervision and detail circuit design.
L. Beale	Construction

* No longer with the NRAO.

The remainder of the project — finalizing systems, check out, calibration, report writing, installation and operation — was done by the author with the assistance of S. Mayor and Telescope Operations.

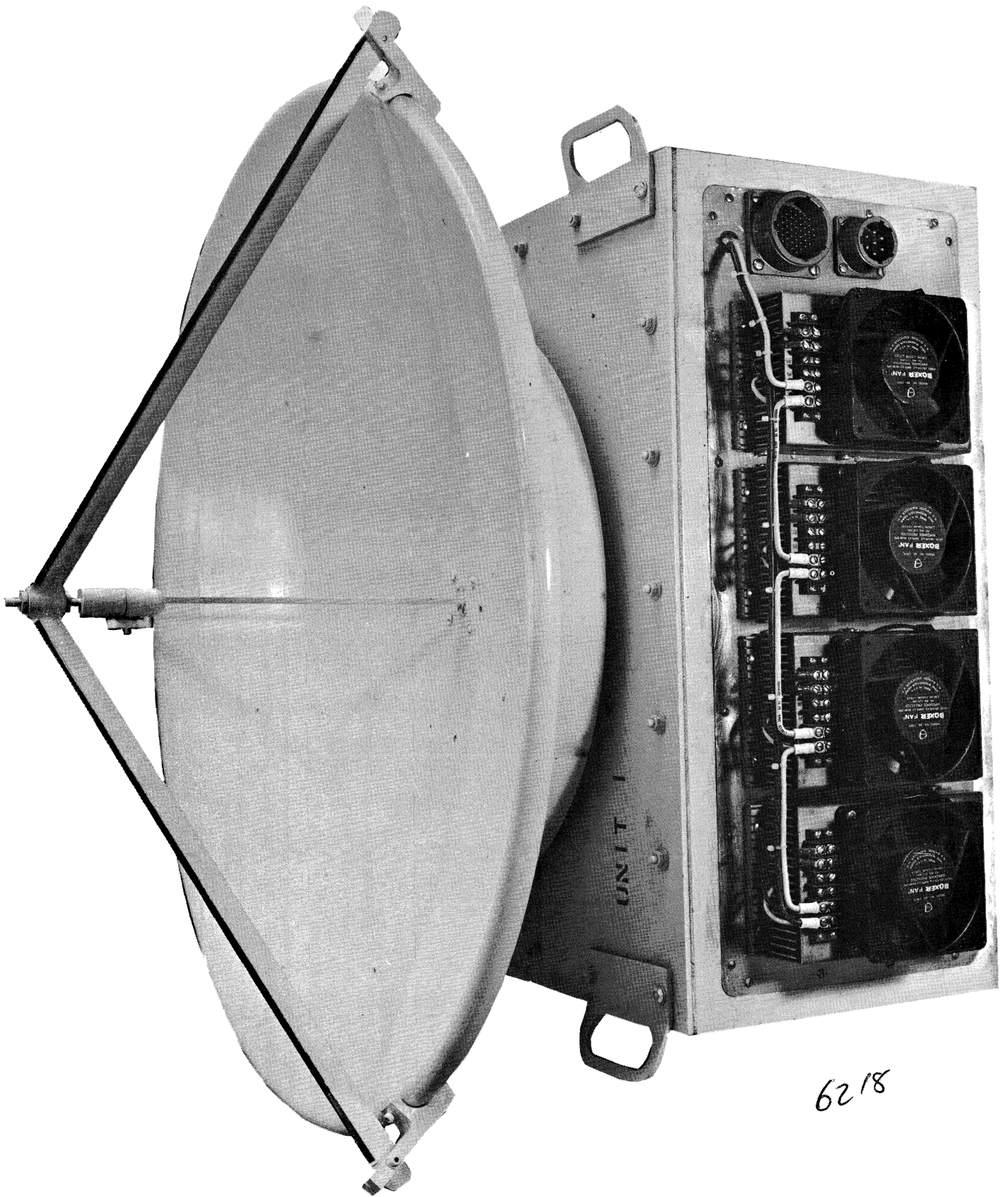

6218

6216

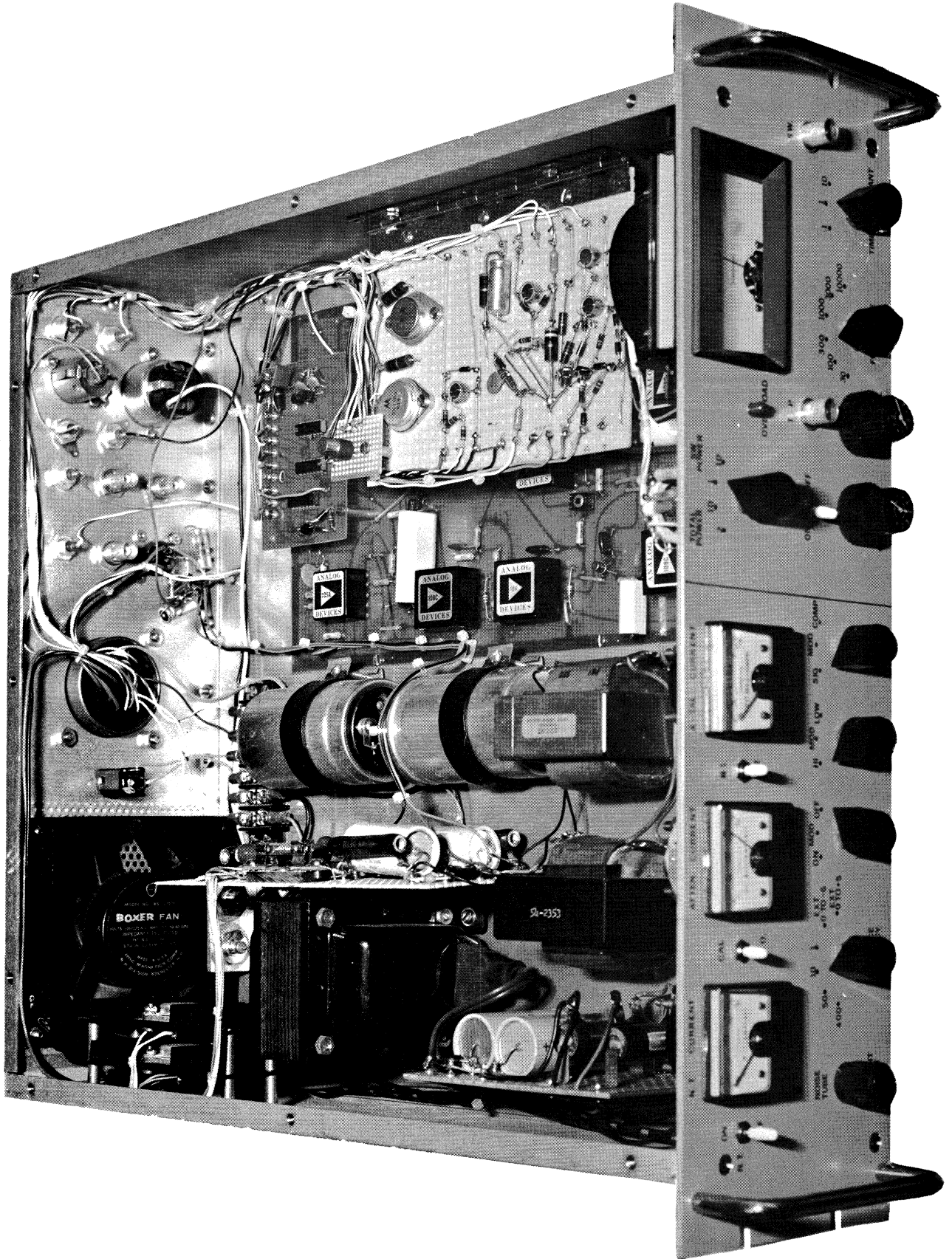

6217

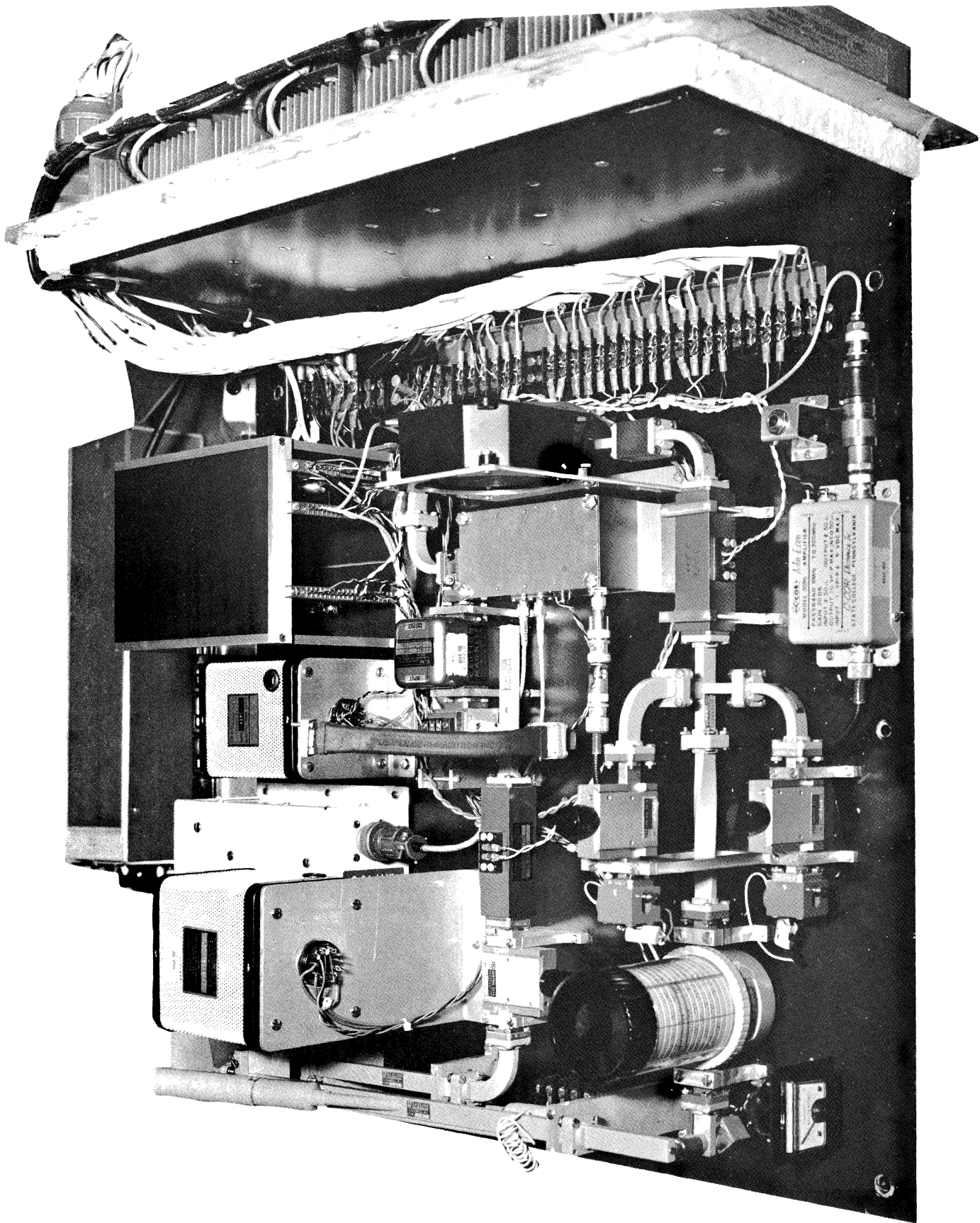

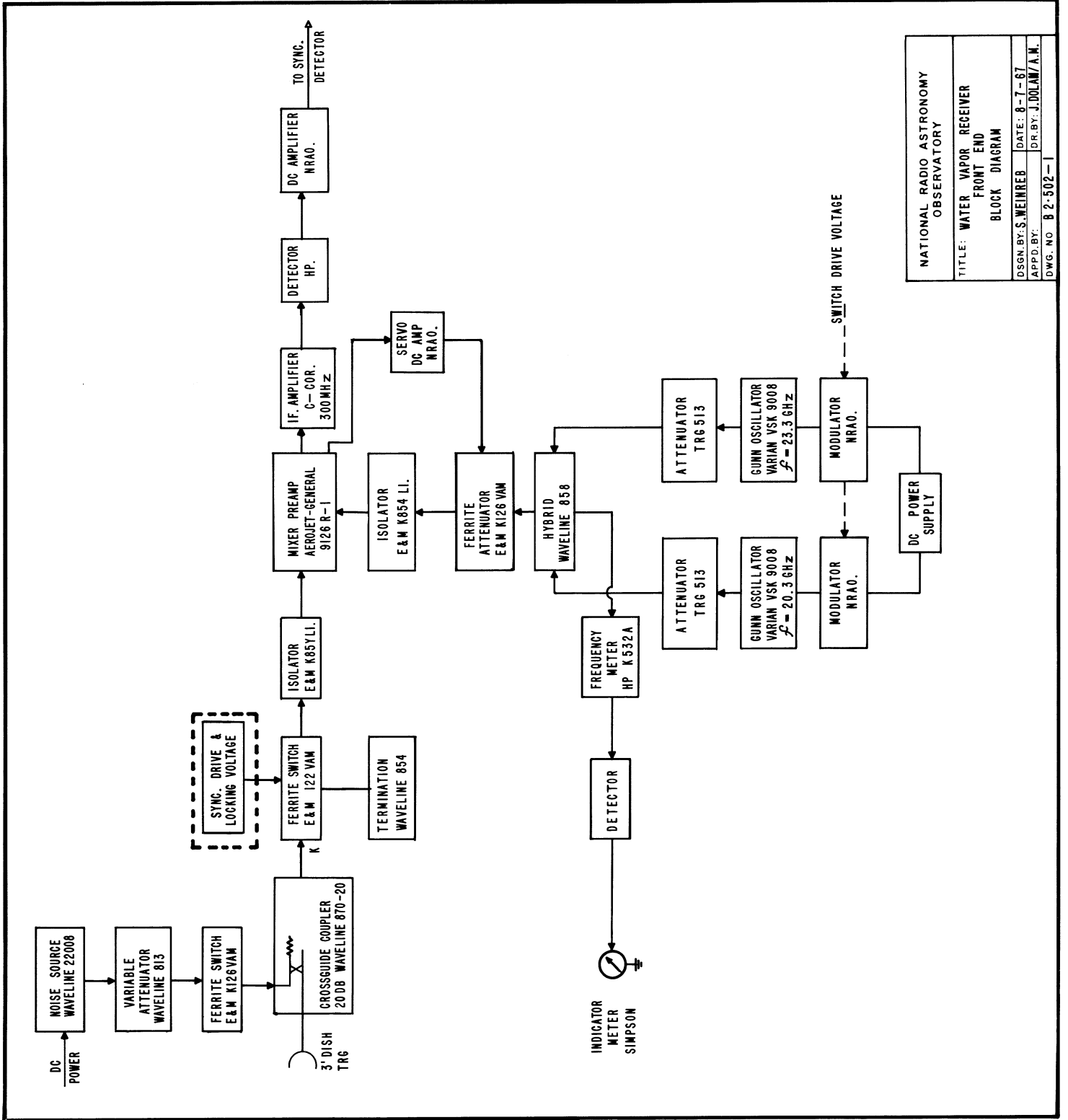

NATIONAL RADIO ASTRONOMY
OBSERVATORY

TITLE: WATER VAPOR RECEIVER
FRONT END
BLOCK DIAGRAM

DSGN. BY: S. WEINREB DATE: 6-7-67
APPD. BY: DR. BY: J. DOLAN/A.M.

DWG. NO. B 2-502-1

50 PIN CONN.
R.P.

6 PIN
POWER CONN.
R.P.

3 PIN CONN.
TEMP. CONTR.
R.P.

R.P. = REAR PANEL
T.S. = TERMINAL STRIP

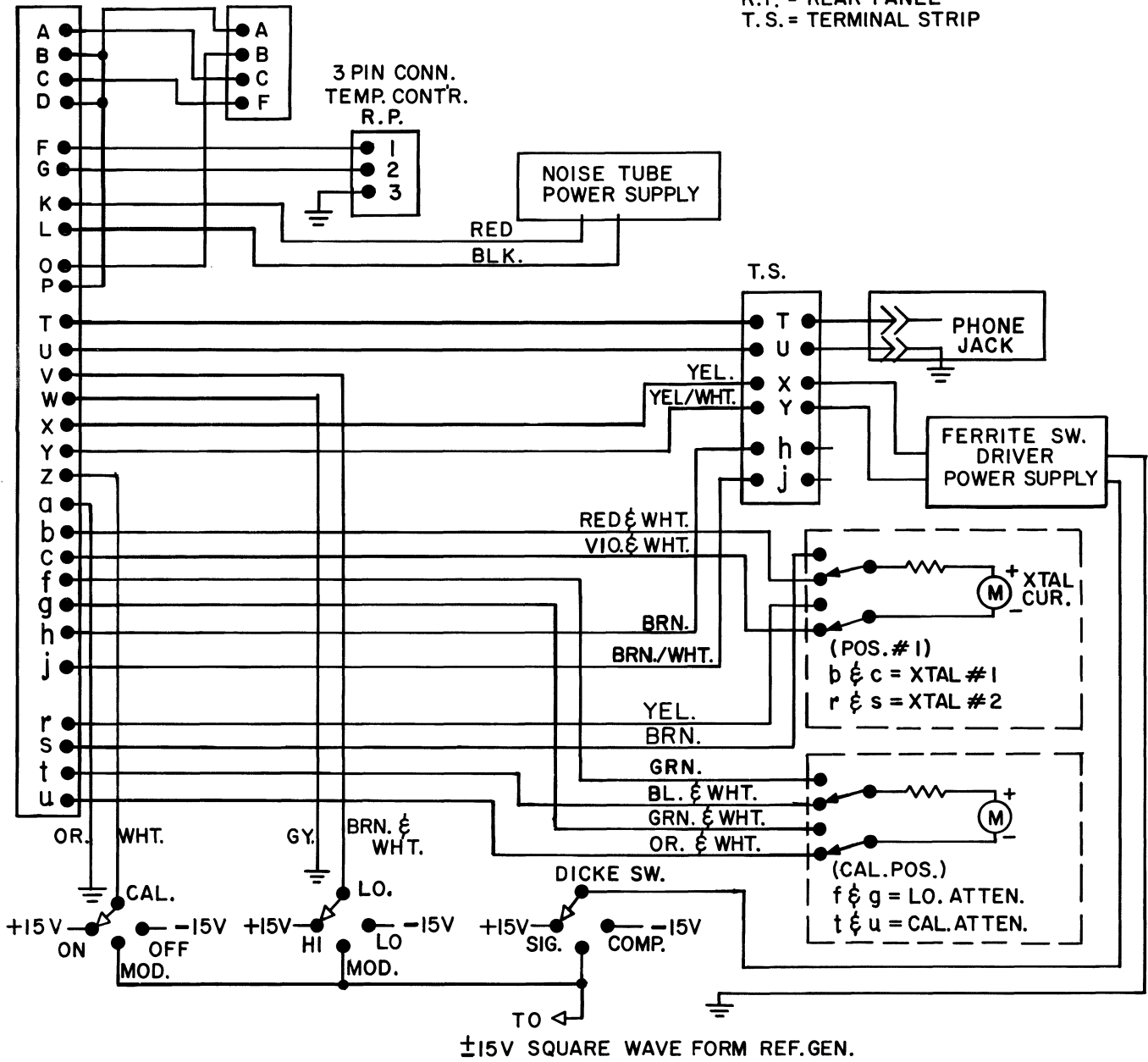

NATIONAL RADIO ASTRONOMY OBSERVATORY	
TITLE: BACKEND CABLE & SWITCH CONNECTIONS FOR WATER VAPOR RECEIVER	
DSGN. BY: THACKER	DATE: 10-30-69
APPD. BY: DOLAN	DR. BY: A.M.
DWG. NO. S 2-502-8	

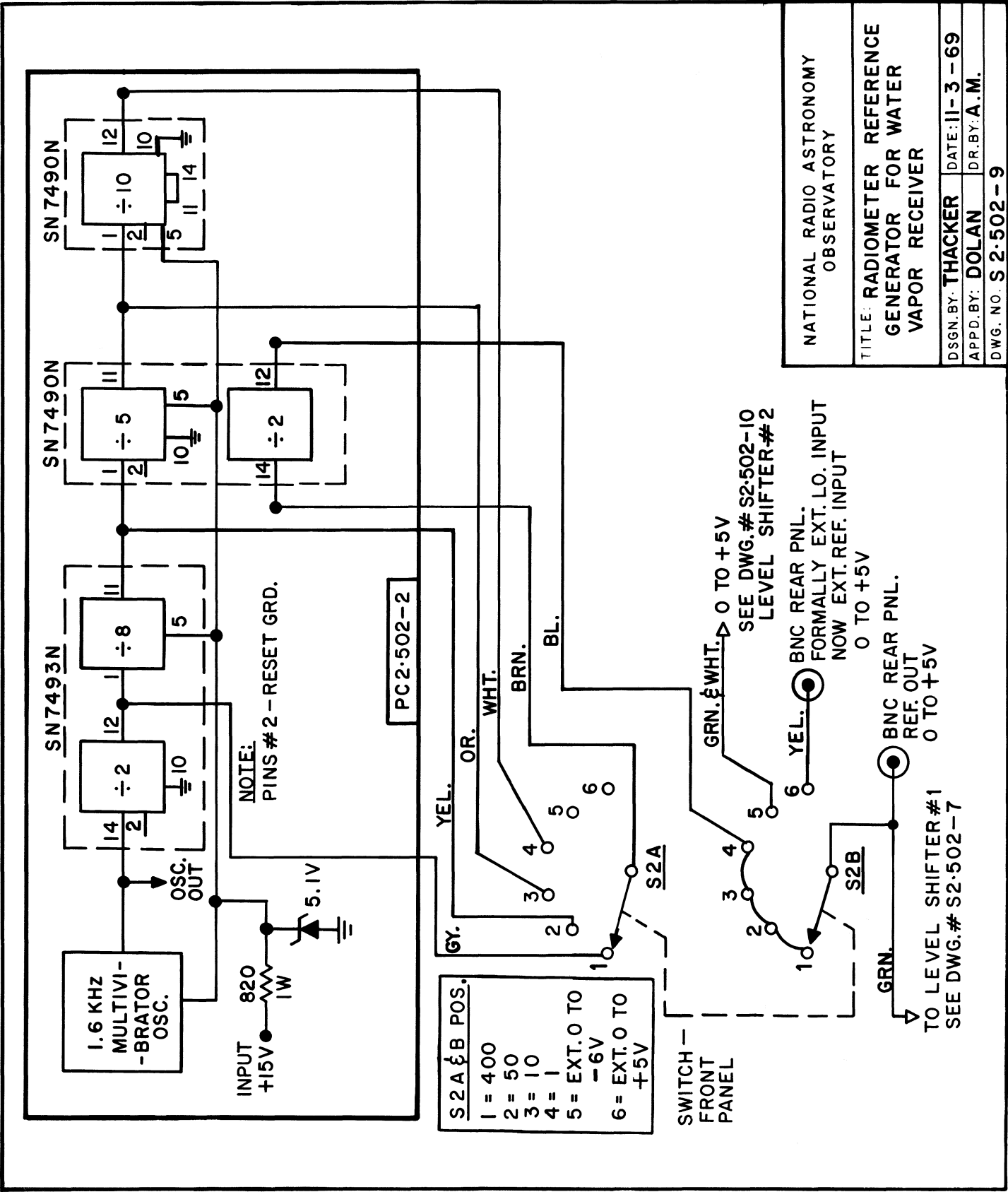

NATIONAL RADIO ASTRONOMY
OBSERVATORY

TITLE: **RADIOMETER REFERENCE
GENERATOR FOR WATER
VAPOR RECEIVER**

DSGN. BY: **THACKER** DATE: **11-3-69**
 APPD. BY: **DOLAN** DR. BY: **A.M.**
 DWG. NO. **S 2.502-9**

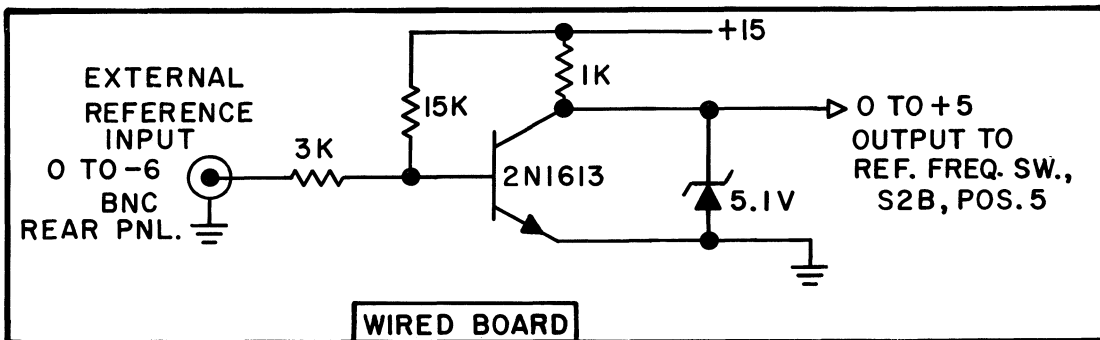

LEVEL SHIFTER # 2

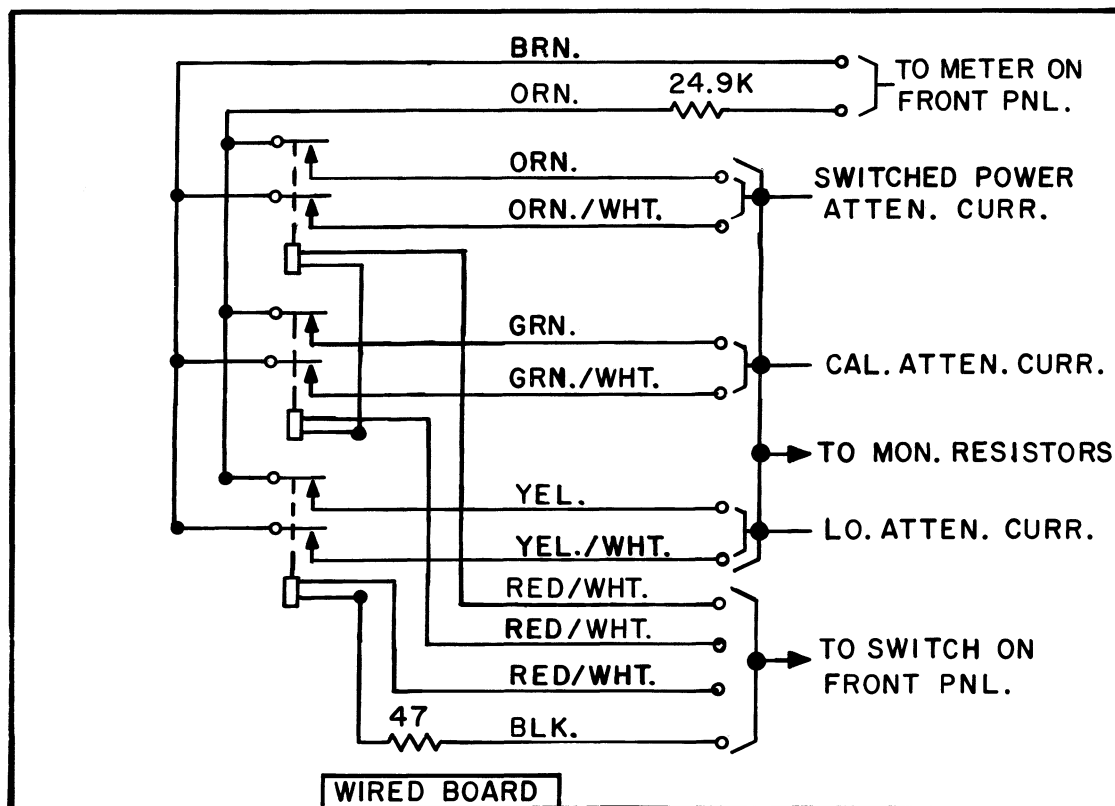

ATTEN. CURR. MON. CKT.

NATIONAL RADIO ASTRONOMY
OBSERVATORY

TITLE: LEVEL SHIFTER # 2 & #
ATTEN. CURR. MON. CKT. FOR
WATER VAPOR RECEIVER

DSGN. BY: THACKER DATE: 11-6-69

APPD. BY: DOLAN DR. BY: A. M.

DWG. NO. S 2-502-10

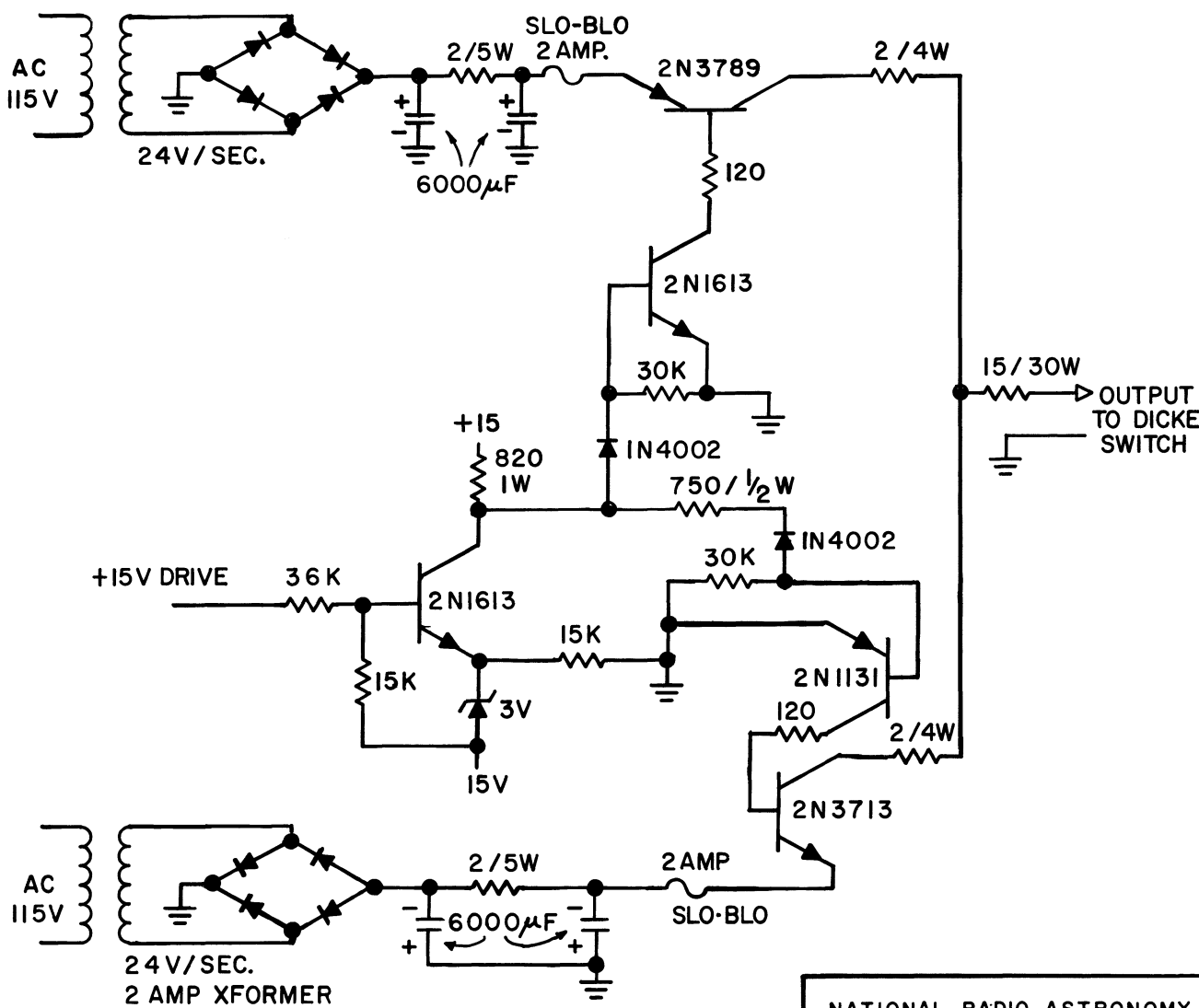

WIRED BOARD

NATIONAL RADIO ASTRONOMY OBSERVATORY	
TITLE: FERRITE SW. DRIVE POWER SUPPLY FOR WATER VAPOR RECEIVER (FRONT END CKT.)	
DSGN. BY: THACKER	DATE: 10-29-69
APPD. BY: DOLAN	DR. BY: A. M.
DWG. NO. S 2-502-6	

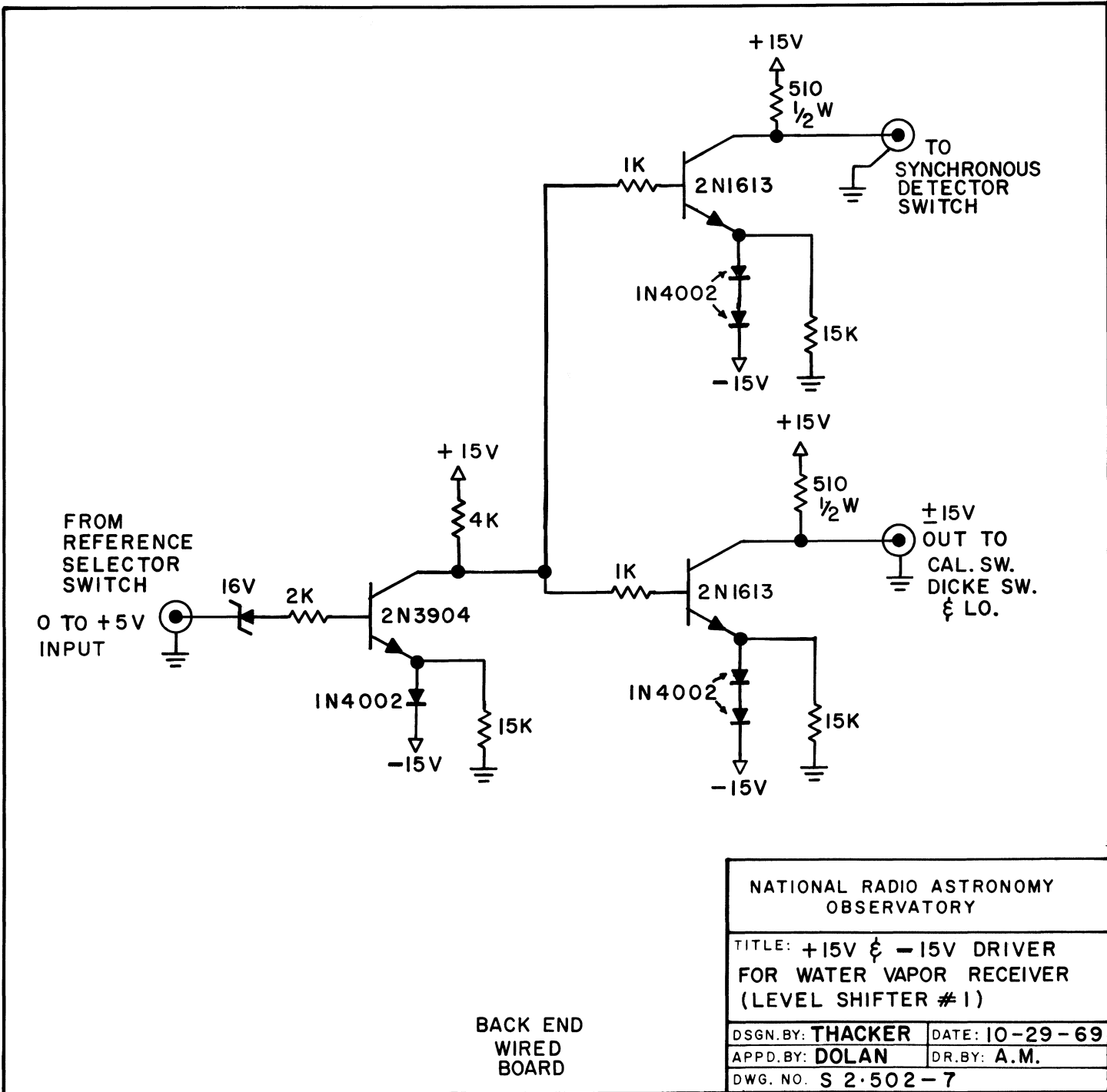

BACK END
WIRED
BOARD

NATIONAL RADIO ASTRONOMY OBSERVATORY	
TITLE: +15V & -15V DRIVER FOR WATER VAPOR RECEIVER (LEVEL SHIFTER #1)	
DSGN. BY: THACKER	DATE: 10-29-69
APPD. BY: DOLAN	DR. BY: A.M.
DWG. NO. S 2.502-7	

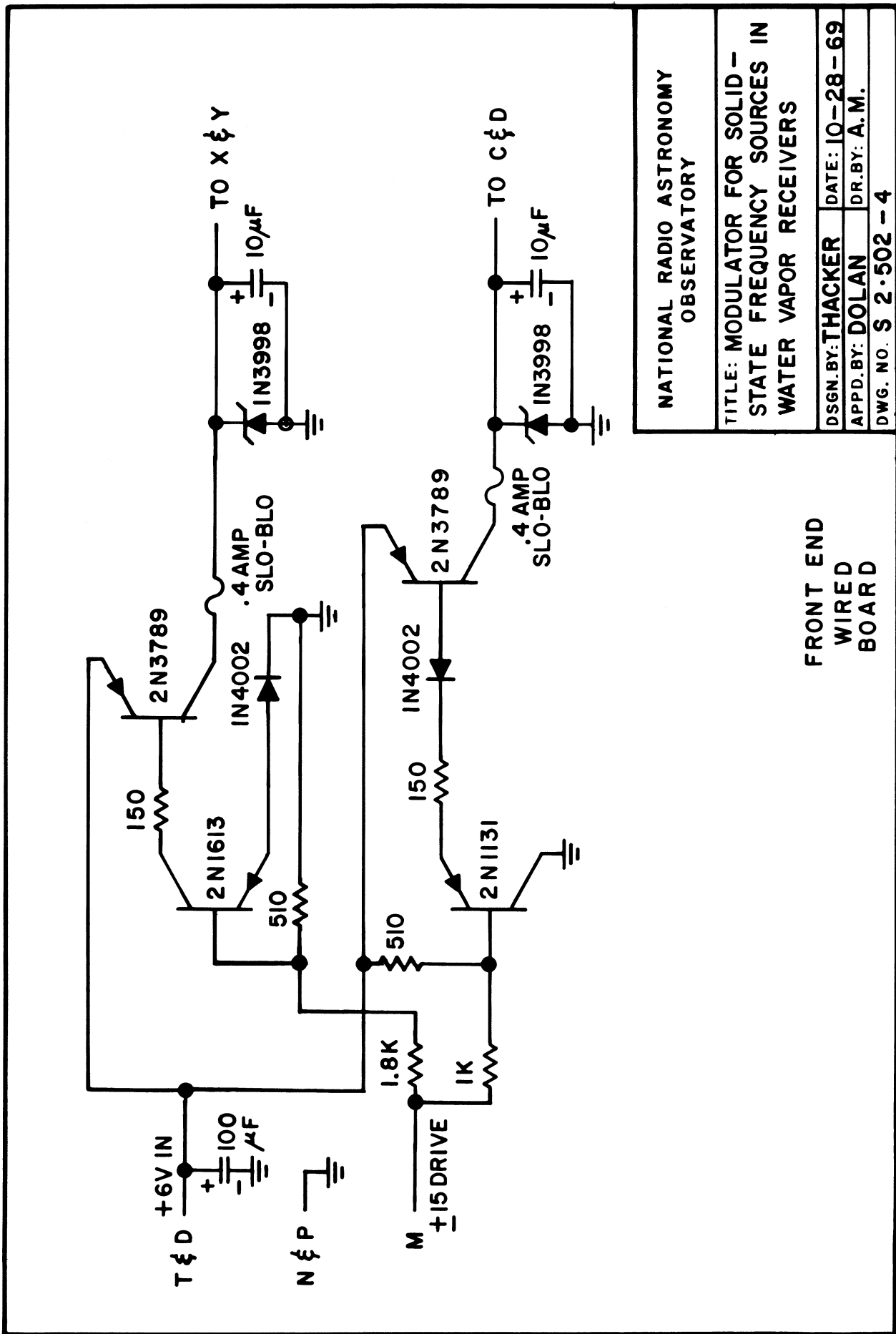

FRONT END
WIRED
BOARD

NATIONAL RADIO ASTRONOMY
OBSERVATORY

TITLE: MODULATOR FOR SOLID -
STATE FREQUENCY SOURCES IN
WATER VAPOR RECEIVERS

DSGN. BY: THACKER DATE: 10-28-69
APPD. BY: DOLAN DR. BY: A. M.
DWG. NO. S 2.502 - 4

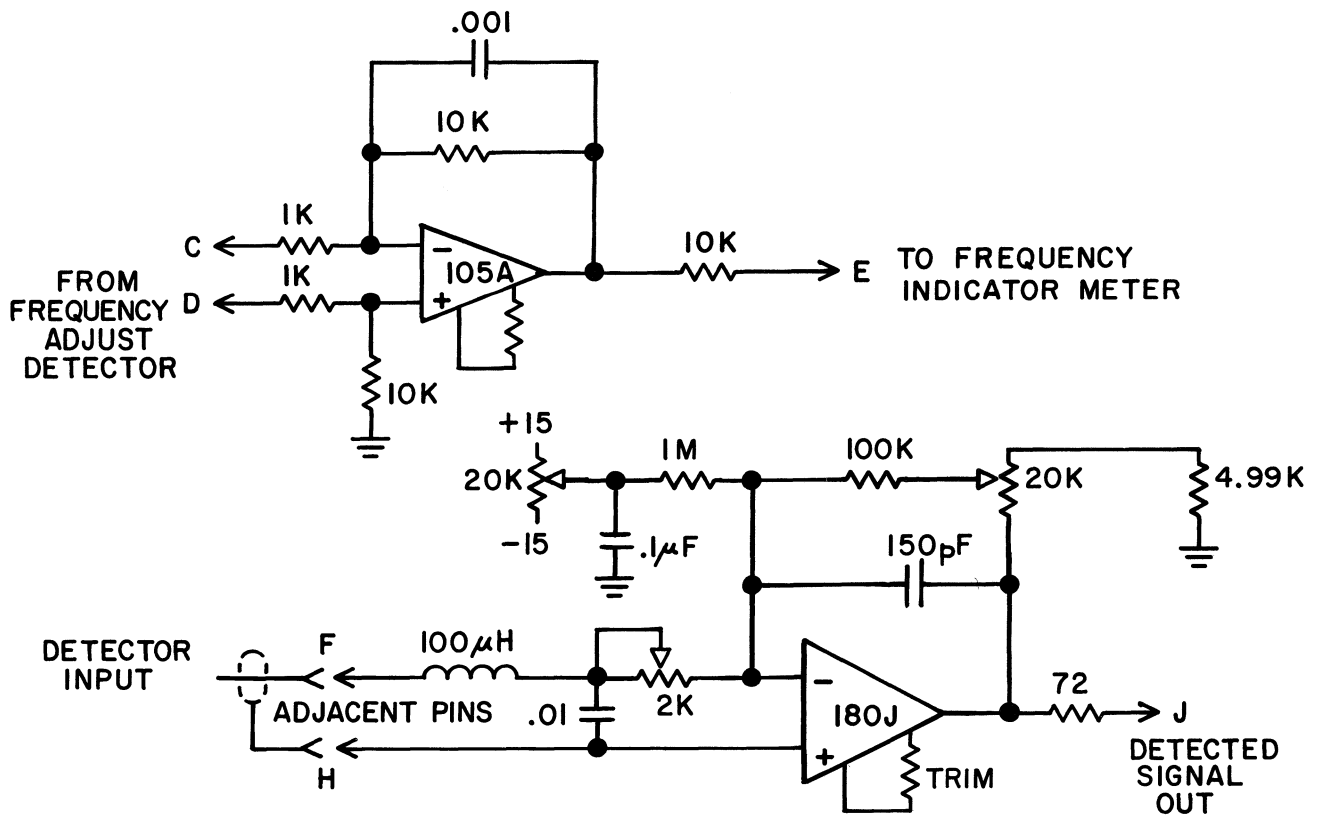

-15V — M
 +15V — L
 GRD. — K

FRONT END
 PRINTED CKT.
 BOARD
 PC 2-502-3

NATIONAL RADIO ASTRONOMY OBSERVATORY	
TITLE: SQUARE LAW DETECTOR & FREQUENCY MONITOR	
DSGN. BY: THACKER	DATE: 10-28-69
APPD. BY: DOLAN	DR. BY: A. M.
DWG. NO. S 2-502-3	

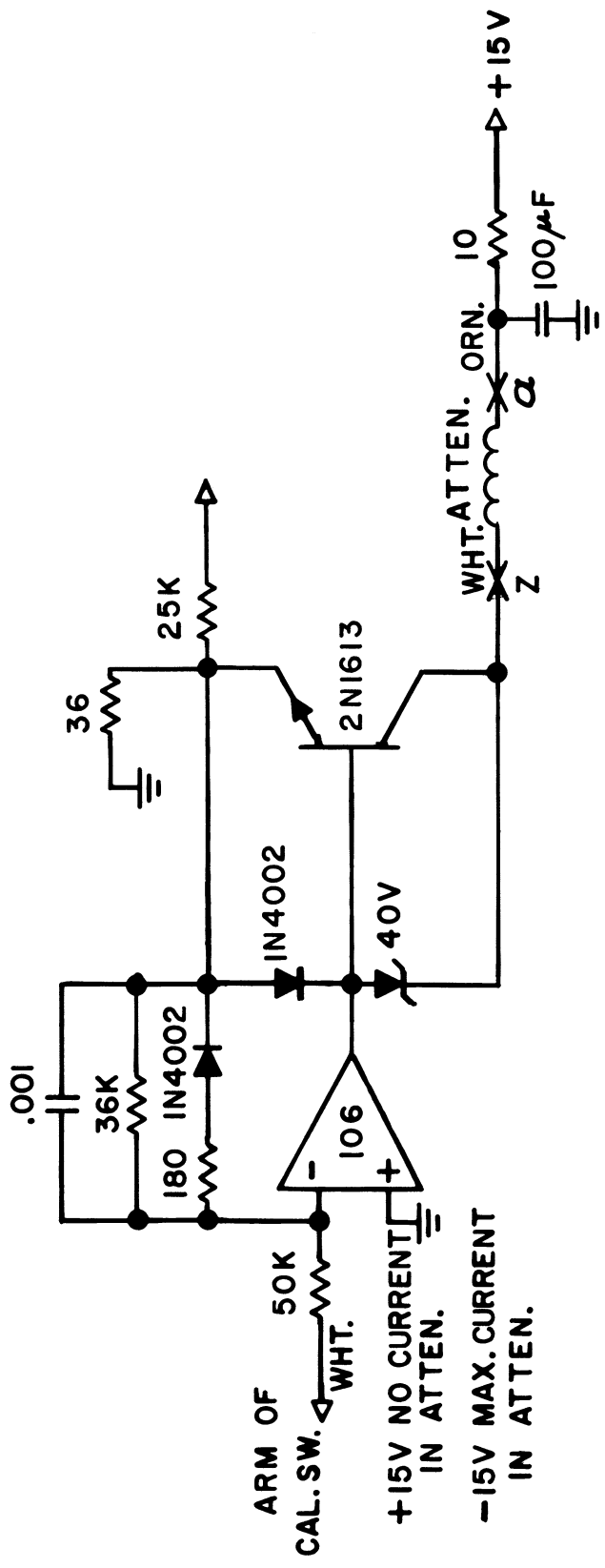

ARM OF
CAL. SW. \triangleleft 50K
WHT.

+15V NO CURRENT
IN ATTEN.

-15V MAX. CURRENT
IN ATTEN.

NATIONAL RADIO ASTRONOMY
OBSERVATORY

TITLE: H₂O RADIOMETER
CAL. SW. (ATTEN.) DRIVER
(BACK END CIRCUIT)

DSGN. BY: THACKER DATE: 10-28-69

APPD. BY: DOLAN DR. BY: A. M.

DWG. NO. S 2-502-5

WIRED BOARD

<u>Color Code Per Pair</u>	<u>Color Code</u>	<u>Pin No.</u>	<u>Remarks</u>	
Blue Tracer	Red	A-1	+15	
	Yellow	B-2	Common	
	Shield	E		
Purple Tracer	Red	C-3	-15	
	Yellow	D-4	Common	
	Shield	J		
Gray Tracer	Red	O-5	+28	
	Yellow	P-6	Common	
	Shield	H		
Green Tracer	Red	F-7)	Thermistor	(Blue)
	Yellow	G-8)	Control	(White)
	Shield	M		
Yellow Tracer	Red	T-9)	Audio	(Blue)
	Yellow	U-10)		(White)
	Shield	N		
Center Pair, No Tracer	Gray	K-11	Noise	(K - Red, 11- White)
	Yellow	L-12	Tube	(L - Black, 12-Red)
	Shield	R		
Center Pair, No Tracer	Blue	X-13	Ferrite Sw.	(Gray)
	Yellow	Y-14	Drive	(Red)
	Shield	Q		
Center Pair, No Tracer	Gray	Z-15)	Op Amp	(Green) (N. T.)
	Red	a-16)	Cal Sig - 7	(Yellow) Attn.)
	Shield	S		
Center Pair, No Tracer	Red	V-17	LO Sig (Card 3)	(Blue)
	Yellow	W-18	(Switch)	(White)
	Shield	d		
Black Tracer	Red	m-19	Det Sig (Card 2)	(Orange)
	Yellow	n-20		(Black)
	Shield	e		
Orange Tracer	Red	b-21	Xtal Curr	(Yellow)
	Yellow	c-22	No. 1	(Black)
	Shield	k		
Red Tracer	Red	r-23	Xtal Curr	(Blue)
	Yellow	s-24	No. 2	(Black)
	Shield	x		
Brown Tracer	Red	t-25	Spare	
	Yellow	u-26		
	Shield	y		
Center Pair, No Tracer	Blue	f-27	LO Atten	(Green)
	Gray	g-28	Current	(Black)
	Shield	p		
Center Pair, No Tracer	Red	h-29	Spare	
	Blue	j-30		
	Shield	q		
Spare Pins (3)		v		
		w		
		z		