

NATIONAL RADIO ASTRONOMY OBSERVATORY
Green Bank, West Virginia

Electronics Division Internal Report No. 88

MULTIFILTER RECEIVERS

D. L. Thacker and Lewis Beale

OCTOBER 1969

NUMBER OF COPIES: 100

MULTIFILTER RECEIVERS

D. L. Thacker and Lewis Beale

TABLE OF CONTENTS

	<u>Page</u>
I. Abstract	(i)
II. General Description	1
III. 40-Channel Receivers — 1 MHz and 5 MHz Channels	4
IV. 50-Channel Receivers — 30 kHz and 10 kHz Channels	17

I. ABSTRACT

- References:
- (1) Electronics Division Internal Report No. 70, "The NRAO 50-Channel Spectral Line Receiver, " by Michael Balister.
 - (2) Electronics Division Internal Report No. 79, "Synchronous Detector and Readout System, " by Kok Chen.
 - (3) Electronics Division Internal Report No. 85, "The 40/50 Channel Integrator/Multiplexer, " by Ray Hallman.
 - (4) Computer Division Internal Report No. 7, "Multi-Channel Receiver On-Line Programs, " by Bob Vance.

This report contains the necessary block diagram and schematics for maintenance and interfacing with the new multifilter receiver plus a general, verbal description to acquaint the users with the filter bank. The above references must be consulted for a complete understanding of the system.

II. GENERAL DESCRIPTION

A set of 5 multifilter banks has been built at NRAO for use on spectral line receivers or pulsar receivers. They are:

1. 50-Channel 100 kHz (hereafter referred to as the old 50-channel) per channel using L. C. tuned amplifier for a contiguous filter bank. For a description of the receiver see EDIR No. 70.
2. 40-Channel 1 MHz per channel using passing L. C. filter (purchased from I-Tel).
3. 40-Channel 5 MHz per channel using passing L. C. filter (purchased from I-Tel).
4. 50-Channel 30 kHz per channel using 10.7 MHz crystal filter and separate LO's for each channel.
5. 50-Channel 10 kHz per channel every 10.7 MHz crystal filters and separate LO's for each channel.

Prototype parts have been ordered for two additional receivers, a 50-channel 100 kHz per channel using 10.7 MHz crystal filter and offset LO's and a 50-channel (300 or 250) kHz per channel using 10.7 MHz L. C. filters and offset LO's.

In building the last four receivers listed above, the output levels, connectors, and input signal conversion that were used on the first 50-channel receiver were followed. (See Table 1.) This allows one to use the same software and interfacing with all systems. There are, of course, minor changes that have to be made when using the 40-channel receiver in place of the 50-channel because of the difference in number of channels. One simple expedient that has been used in the past has been to simulate channels 41-50 by jumping selected channels of the receiver outputs to the 41-50 channel input of the computer interface.

For more information on the integration of the line receiver with the DDP-116 computer, see section 3 of EDIR No. 70.

The following block diagram shows this chief difference between the 40-channel receiver and the new 50-channel receiver and it also should clarify crystal filter offset LO techniques. (See Figure 1 and Table 1.)

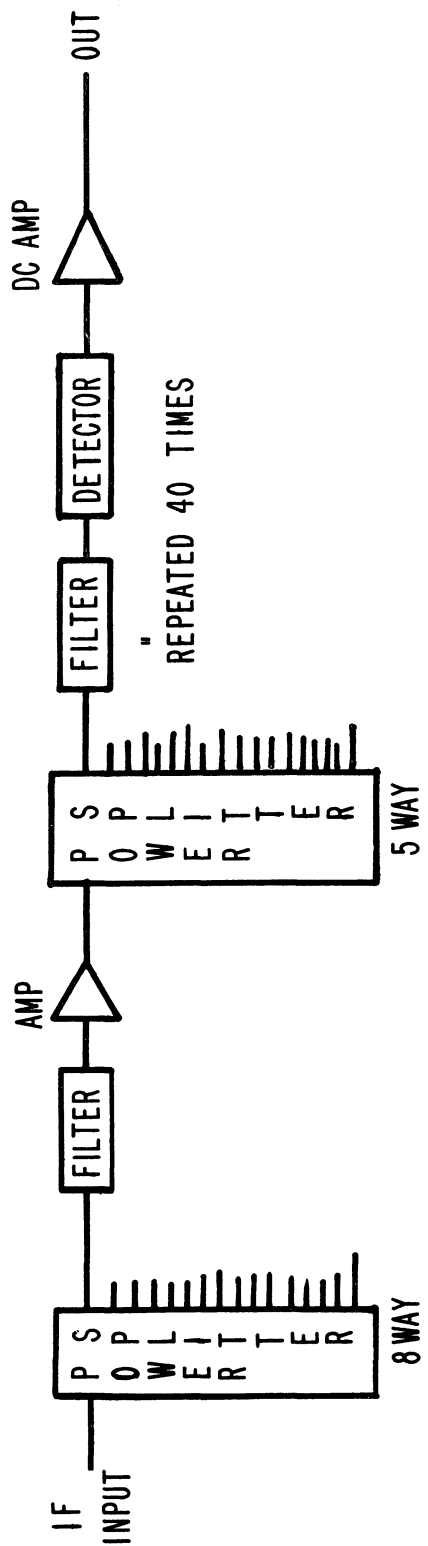

40 CHANNEL

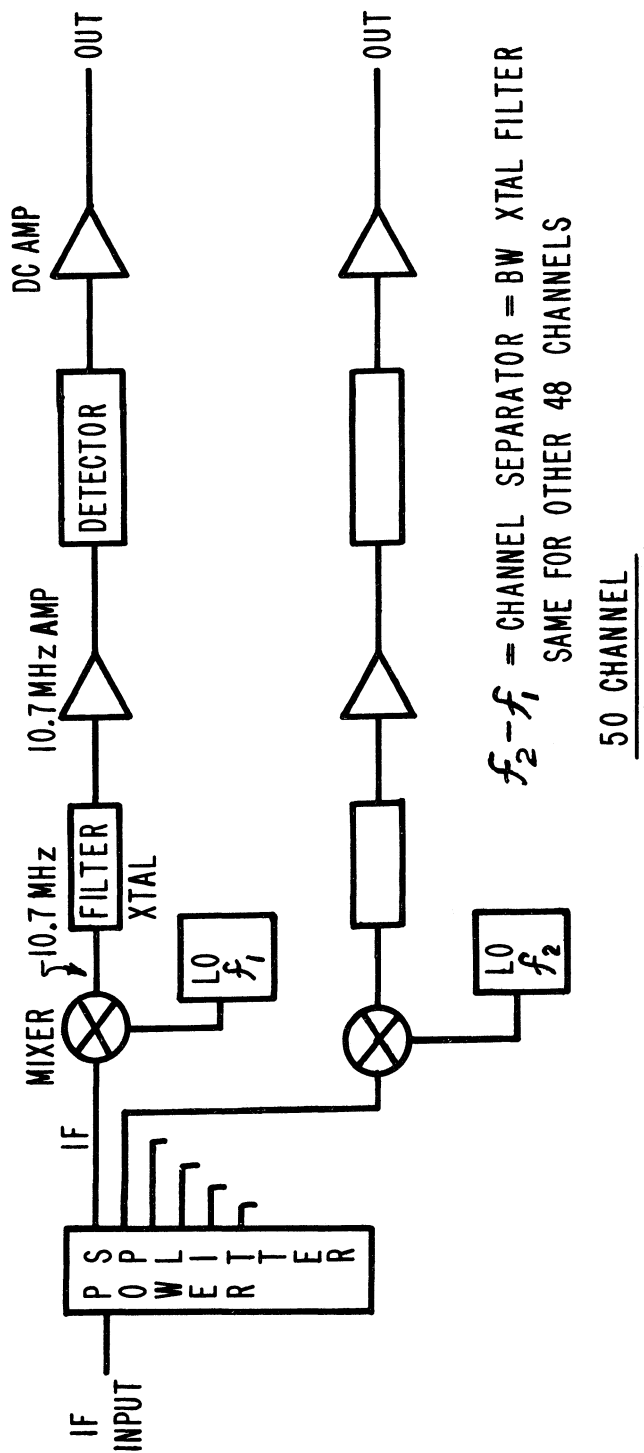

FIG. 1

TABLE 1

Multifilter Receiver	Number of Channels	IF Frequency	Resolution (Channel Width)
1. 50-Channel 100 kHz (old)	50	147.5-152.5	100 kHz (1 dB)
2. 40-Channel 1 MHz	40	70.5-110.5	1 MHz (3 dB)
3. 40-Channel 5 MHz	40	50-250	5 MHz (3 dB)
4. 50-Channel 30 kHz	50	29.25-30.75	30 kHz (6 dB nom.)
5. 50-Channel 10 kHz	50	29.74-30.24	10 kHz (6 dB nom.)

III. 40-CHANNEL RECEIVERS

The two 40-channel receivers show a common IF driven box and therefore cannot be used simultaneously. Change over time from one bandwidth to another is approximately 1/2 hour. Note that the driver unit has a specially keyed DC power connector which prevents plugging in a standard DC power cord. Do not try to defeat its purpose.

Table 2 lists the nominal center frequencies and bandwidths of the fixed, tuned 3-section L. C. filters that are used in the receivers. There is some distortion of the expected filter band shape and center frequency caused by the interaction of adjacent filters. This rarely causes a shift in center frequency of a channel larger than 30 percent of the channel bandwidth. The block diagram, schematics (Figs. 1-5), rear panel connector listings (Tables 3-5), and photographs are self-explanatory. Channels 41-50 on the 40-channel are left open-circuited.

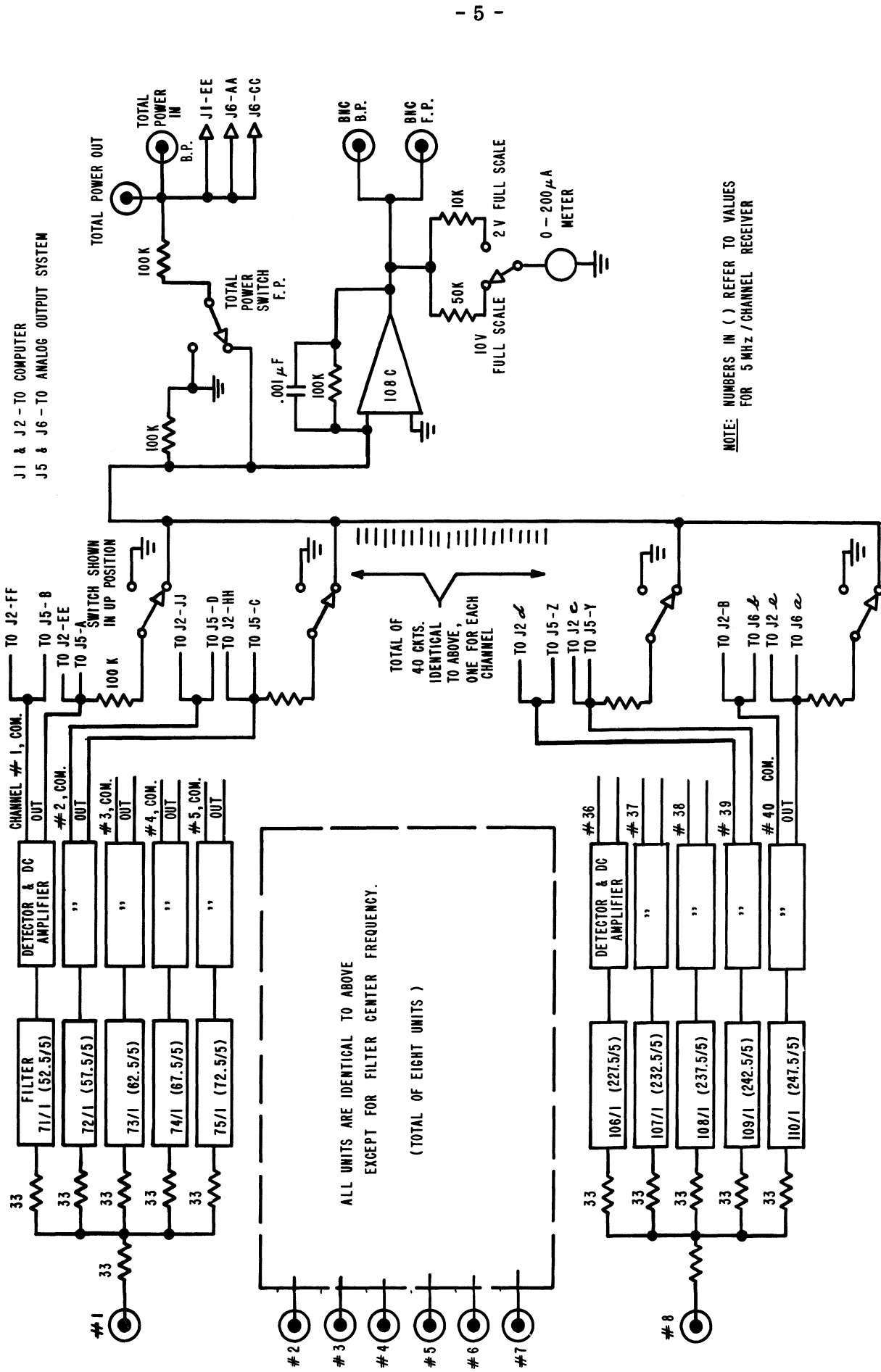

BLOCK DIAGRAM OF 40 CHANNEL MULTIFILTER RECEIVERS FILTER BANK

FIG. 2

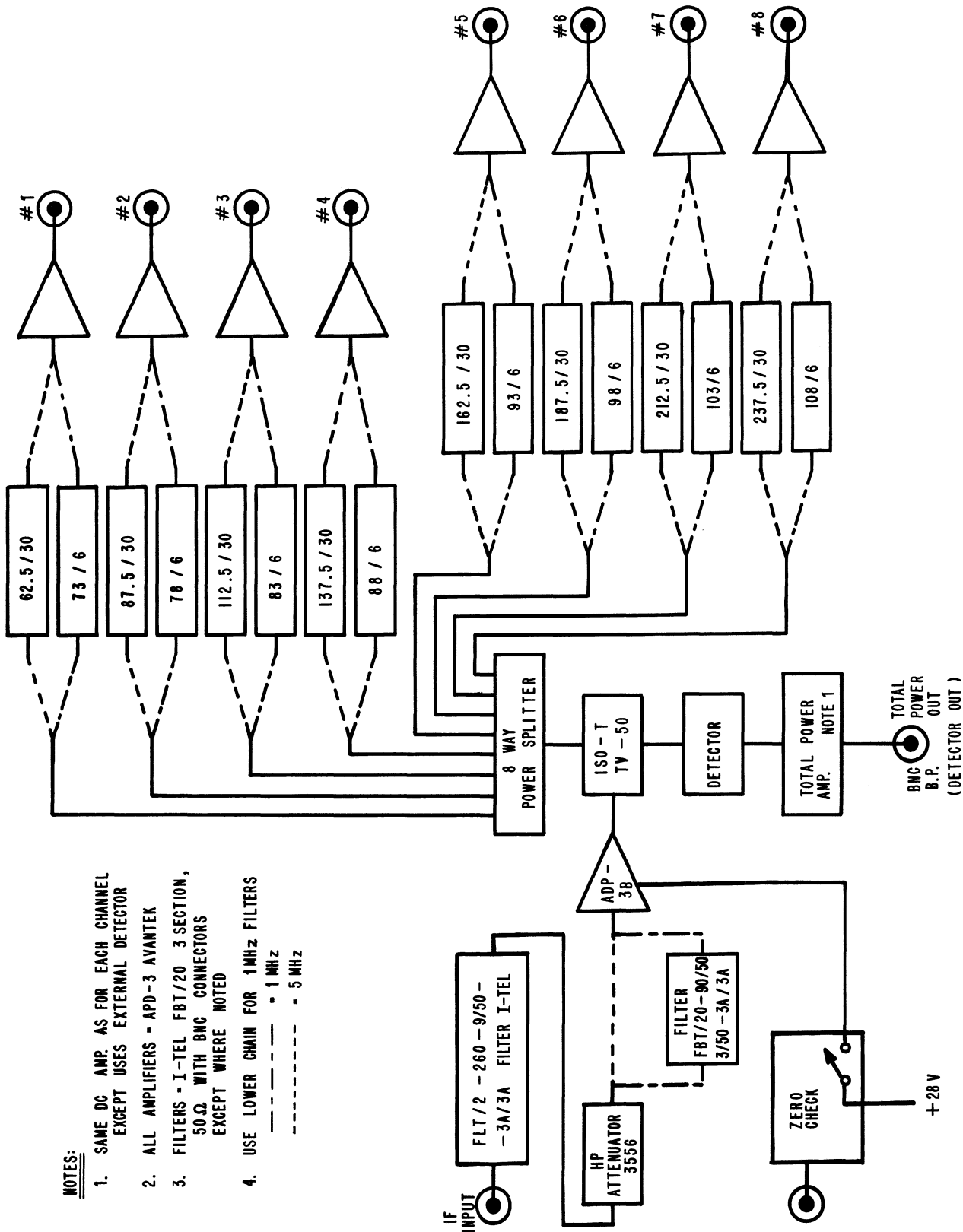

NOTES:

1. SAME DC AMP. AS FOR EACH CHANNEL EXCEPT USES EXTERNAL DETECTOR
2. ALL AMPLIFIERS - APD-3 AVANTEK
3. FILTERS - I-TEL FBT/20 3 SECTION, 50Ω WITH BNC CONNECTORS EXCEPT WHERE NOTED
4. USE LOWER CHAIN FOR 1MHZ FILTERS
 - - - - - 1 MHZ
 - - - - - 5 MHZ

BLOCK DIAGRAM OF 40 CHANNEL MULTIFILTER RECEIVER DRIVER DRAWER

FIG. 3

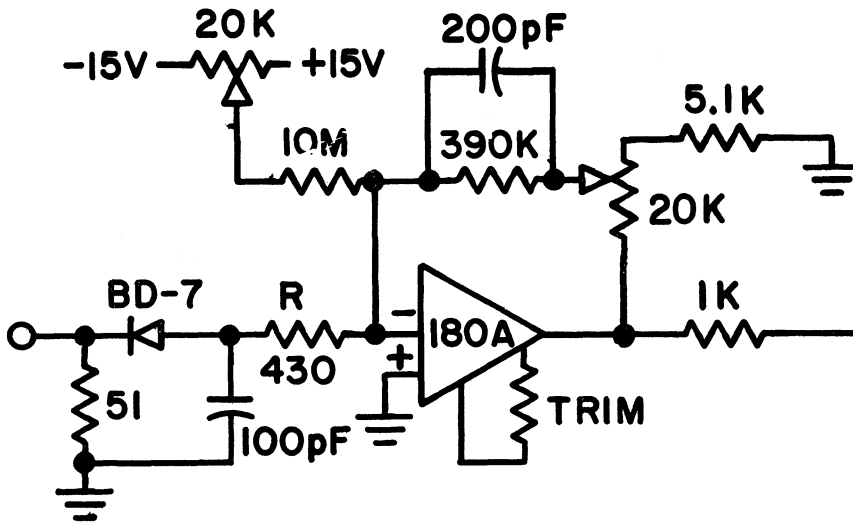

TRIM RESISTOR SUPPLIED WITH AMP.
R - SELECTED FOR BEST SQUARE LAW CHARACTERISTICS,
TYPICAL VALUE ABOUT 430Ω.
CKTS. - SAME FOR 5 & 1 MHz RECEIVERS

DETECTOR & DC AMPLIFICATION FOR
40 CHANNEL RECEIVERS

FIG. 4

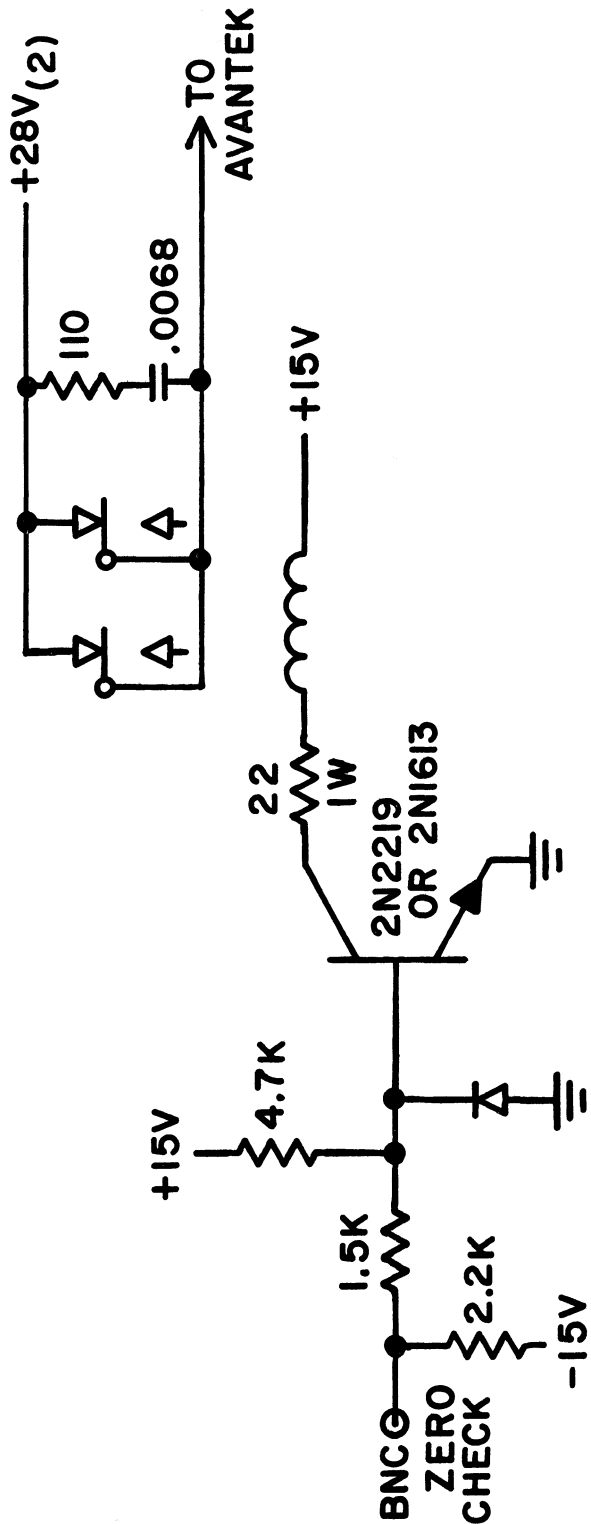

0 VOLTS = 0 (7 mA)
-6 VOLTS OR OPEN CKT. = OPERATE

ZERO CHECK CKT. for 40 CHANNEL DRIVER

FIG. 5

TABLE 2

Channel Number	Center Frequencies		Channel Number
	5 MHz Bandwidth	1 MHz Bandwidth	
1	52.5	71	1
2	57.5	72	2
3	62.5	73	3
4	67.5	74	4
5	72.5	75	5
6	77.5	76	6
7	82.5	77	7
8	87.5	78	8
9	92.5	79	9
10	97.5	80	10
11	102.5	81	11
12	107.5	82	12
13	112.5	83	13
14	117.5	84	14
15	122.5	85	15
16	127.5	86	16
17	132.5	87	17
18	137.5	88	18
19	142.5	89	19
20	147.5	90	20
21	152.5	91	21
22	157.5	92	22
23	162.5	93	23
24	167.5	94	24
25	172.5	95	25
26	177.5	96	26
27	182.5	97	27
28	187.5	98	28
29	192.5	99	29
30	197.5	100	30
31	202.5	101	31
32	207.5	102	32
33	212.5	103	33
34	217.5	104	34
35	222.5	105	35
36	227.5	106	36
37	232.5	107	37
38	237.5	108	38
39	242.5	109	39
40	247.5	110	40

TABLE 3
Back Panel Connectors, Cable Connection, and Color Code for
40 and 50 Channel

J1 Pin	Filter Bank	Channel Number	Analog Buffer Channel No.	Color Code
A	Sig	3	16	Red
B	Ret			Black
C	Sig	4	17	White
D	Ret			Black
E	Sig	5	18	Green
F	Ret			Black
H	Sig	6	19	Blue
J	Ret			Black
K	Sig	7	20	Brown
L	Ret			Black
M	Sig	8	21	Yellow
N	Ret			Black
P	Sig	9	22	Orange
R	Ret			Black
S	Sig	10	23	Green
T	Ret			Red
U	Sig	11	24	White
V	Ret			Red
W	Sig	12	25	Blue
X	Ret			Red
Y	Sig	13	26	Yellow
Z	Ret			Red
a	Sig	14	27	Brown
b	Ret			Red
c	Sig	15	28	Orange
d	Ret			Red

Continued --

Table 5 (continued) —

J5 Pin	Filter Bank	Channel Number	Color Code
h	Sig	15	White
j	Ret		Green
k	Sig	16	Brown
l	Ret		Green
m	Sig	17	Orange
n	Ret		Green
p	Sig	18	Yellow
r	Ret		Green
s	Sig	19	Blue
t	Ret		White
u	Sig	20	Brown
v	Ret		White
w	Sig	21	Orange
x	Ret		White
y	Sig	22	Yellow
z	Ret		White
AA	Sig	23	Brown
BB	Ret		Blue
CC	Sig	24	Orange
DD	Ret		Blue
EE	Sig	25	Yellow
FF	Ret		Blue
HH	Sig	26	Orange
JJ	Ret		Brown
KK	Sig	27	Yellow
LL	Ret		Brown
MM	Sig	28	Red
NN	Ret		Violet

TABLE 6

Back Panel Connectors, Cable Connection, and Color Code for 40 and 50 Channel

J6 Pin	Filter Bank	Channel Number	Color Code	J6 Pin	Filter Bank	Channel Number	Color Code
A	Sig	29	Red	h	Sig	43	White
B	Ret		Black	j	Ret		Green
C	Sig	30	White	k	Sig	44	Brown
D	Ret		Black	l	Ret		Green
E	Sig	31	Green	m	Sig	45	Orange
F	Ret		Black	n	Ret		Green
H	Sig	32	Blue	p	Sig	46	Yellow
J	Ret		Black	r	Ret		Green
K	Sig	33	Brown	s	Sig	47	Blue
L	Ret		Black	t	Ret		White
M	Sig	34	Yellow	u	Sig	48	Brown
N	Ret		Black	v	Ret		White
P	Sig	35	Orange	w	Sig	49	Orange
R	Ret		Black	x	Ret		White
S	Sig	36	Green	y	Sig	50	Yellow
T	Ret		Red	z	Ret		White
U	Sig	37	White	AA	Sig	51	Total power
V	Ret		Red	BB	Ret		from BNC
W	Sig	38	Blue	CC	Sig	52	Total power
X	Ret		Red	DD	Ret		from BNC
Y	Sig	39	Yellow	EE	Sig	53	Spare
Z	Ret		Red	FF	Ret		
a	Sig	40	Brown	HH	Gnd	54	Spare
b	Ret		Red	JJ	Gnd		
c	Sig	41	Orange	KK	Gnd	55	Spare
d	Ret		Red	LL	Gnd		
e	Sig	42	Blue	MM	Gnd		Spare
f	Ret		Green	NN	Gnd		

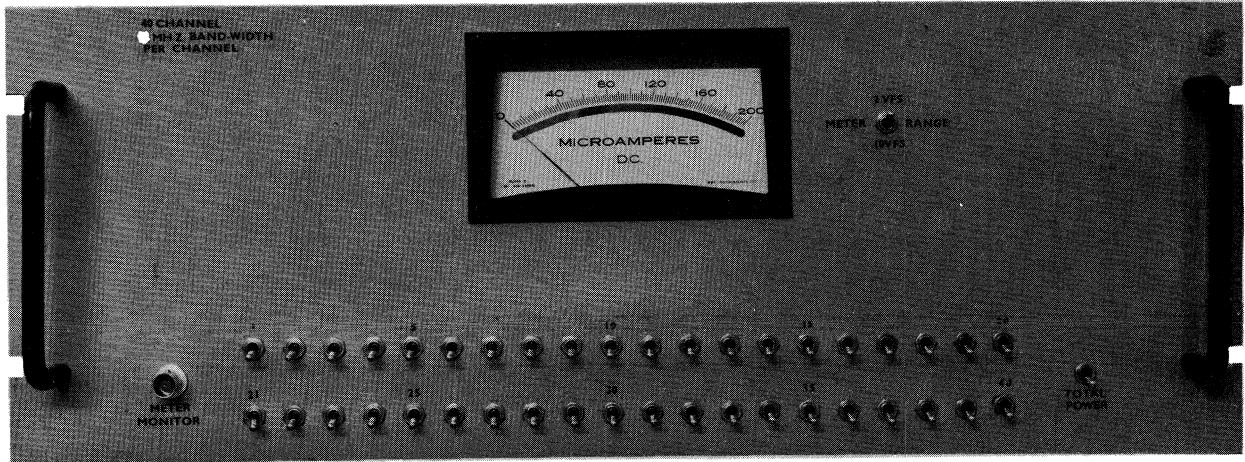

6221

Front Panel of 5 MHz Receiver

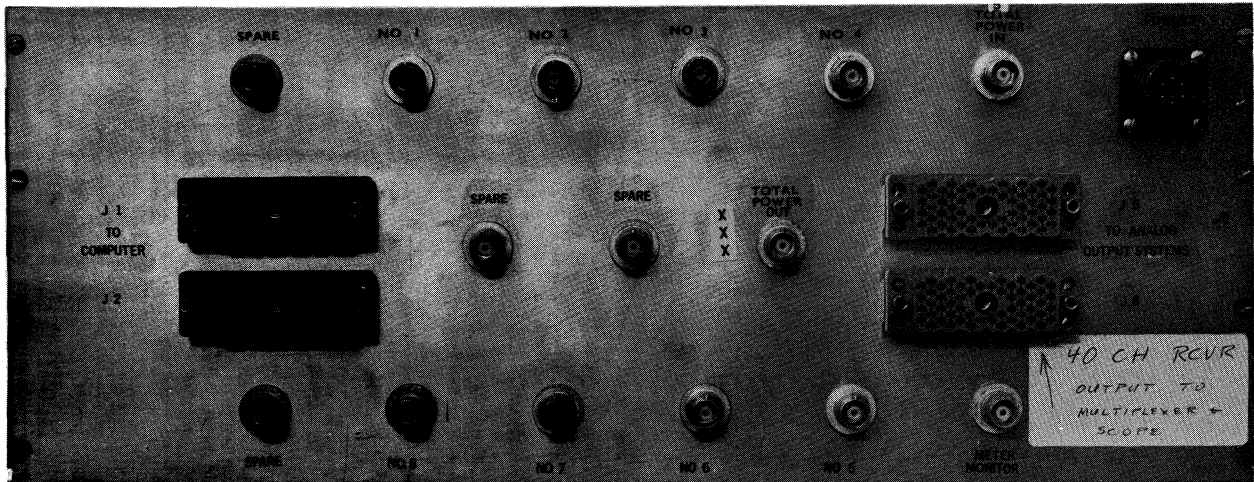

6221

Back Panel of 5 MHz Receiver

IV. NEW 50-CHANNEL RECEIVER

The 10 kHz and 30 kHz 50-channel receivers use the fixed filter, offset LO technique, that is shown in Figure 1. This permits the use of a standard filter to determine the bandpass characteristic of the channel, which results in greater repeatability from channel to channel plus greater economy. The center frequencies of the channels are determined by crystal oscillators, which gives better stability than L. C. filters plus the freedom to easily change center frequencies.

The 10 and 30 kHz receivers are similar in design with the only differences being the crystal filter and its matching resistors and the crystal frequency of the channel LO. Mechanically, the receivers are identical, which allows printed circuit cards to be interchanged or mixed.

Output connectors and zero check levels are the same as on other receivers. Output level is nominally +1 volt DC.

The following diagrams (Figs. 6-9), tables, and photographs are to assist in troubleshooting and repair and are essentially self-explanatory (Figs. 7-8). The cost for parts is approximately \$100 per channel.

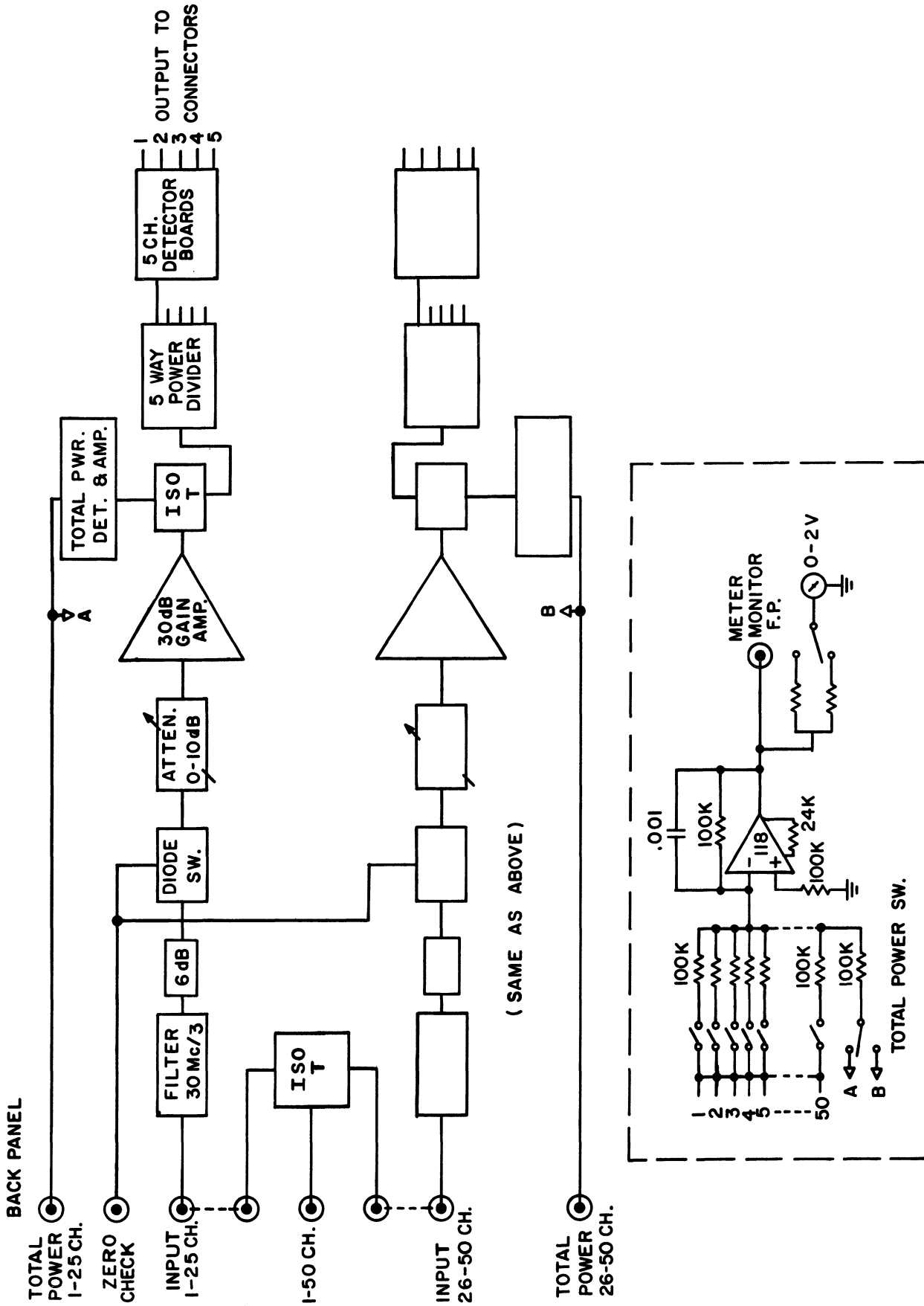

BLOCK DIAGRAM OF 50 CHANNEL RECEIVER

Figure 6

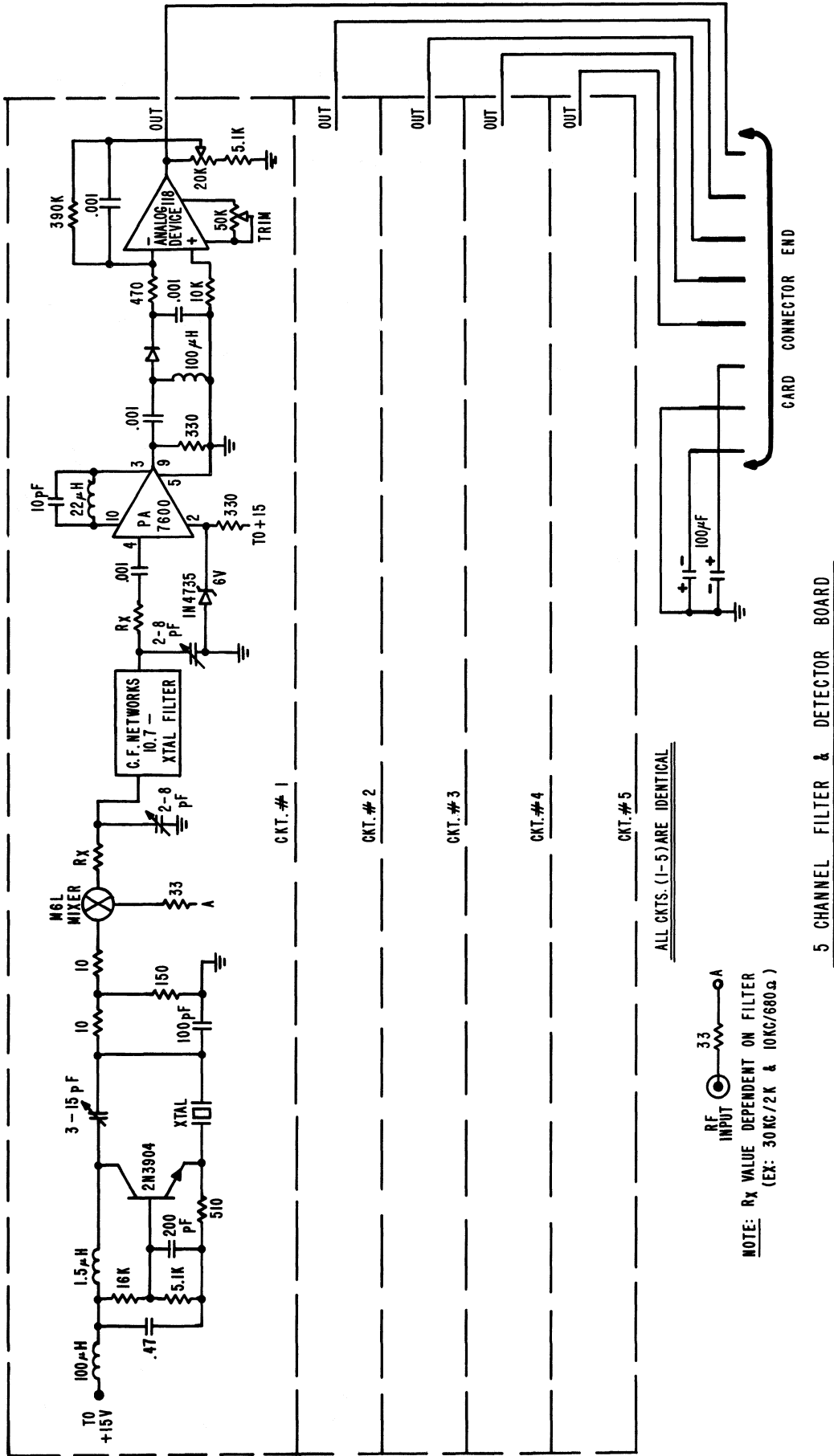
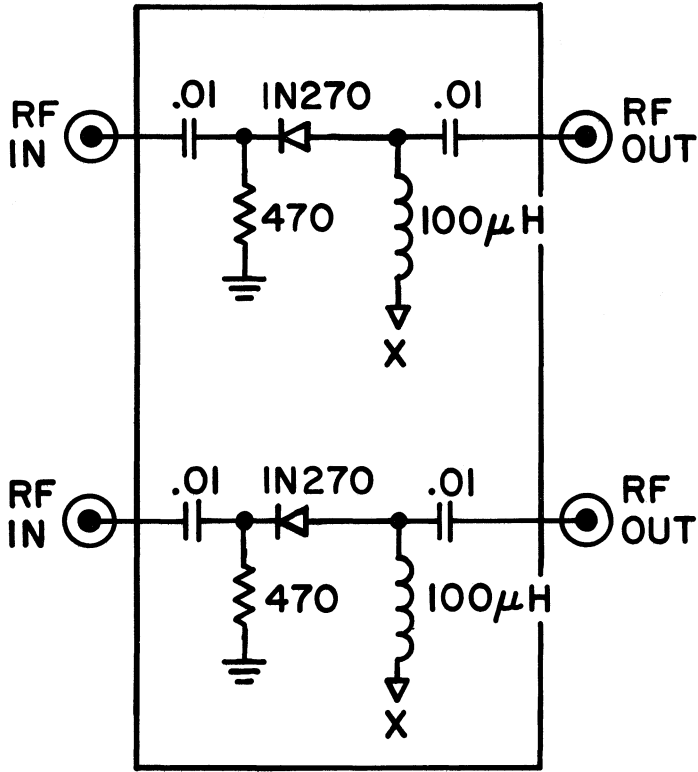
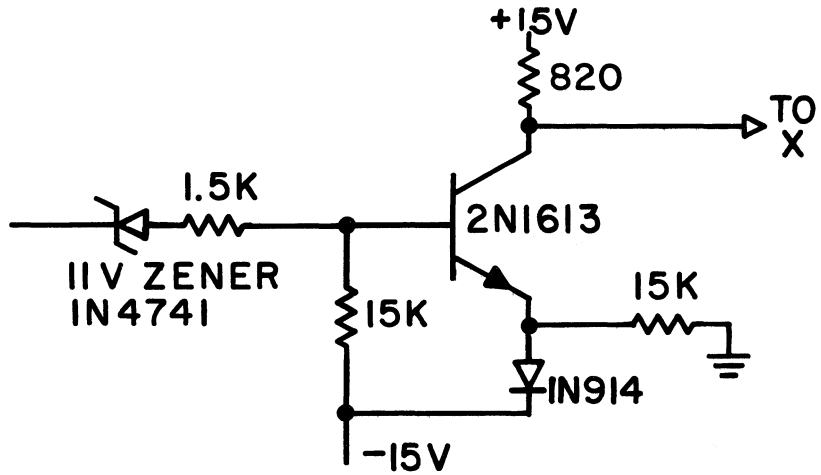

Figure 7



DIODE SWITCH



DIODE SWITCH DRIVER

50 CHANNEL MULTIFILTER 10-30KHz

Figure 8

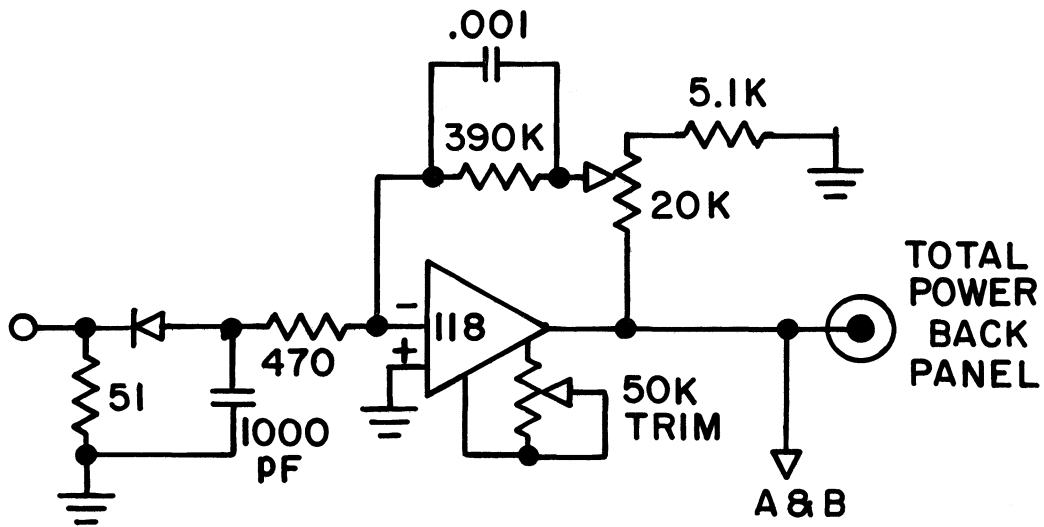

CKTS.-SAME FOR-30 & 10-KHz

TOTAL POWER DETECTOR & DC AMPLIFICATION FOR
50 CHANNEL RECEIVERS

Figure 9

TABLE 7

Crystal Frequency and Channel Center Frequency for the 30 kHz Multifilter Receiver

Channel Number	Channel Frequency Number	Channel LO (Crystal Oscillator Frequency)	Channel Number	Channel Number	Channel Frequency Number	Channel LO (Crystal Oscillator Frequency)	Channel Number
1	29.265	39.965	1	26	30.015	40.715	26
2	29.295	39.995	2	27	30.045	40.745	27
3	29.325	40.025	3	28	30.075	40.775	28
4	29.355	40.055	4	29	30.105	40.805	29
5	29.385	40.085	5	30	30.135	40.835	30
6	29.415	40.115	6	31	30.165	40.865	31
7	29.445	40.145	7	32	30.195	40.895	32
8	29.475	40.175	8	33	30.225	40.925	33
9	29.505	40.205	9	34	30.255	40.955	34
10	29.535	40.235	10	35	30.285	40.985	35
11	29.565	40.265	11	36	30.315	41.015	36
12	29.595	40.295	12	37	30.345	41.045	37
13	29.625	40.325	13	38	30.375	41.075	38
14	29.655	40.355	14	39	30.405	41.105	39
15	29.685	40.385	15	40	30.435	41.135	40
16	29.715	40.415	16	41	30.465	41.165	41
17	29.745	40.475	17	42	30.495	41.195	42
18	29.775	40.475	18	43	30.525	41.225	43
19	29.805	40.505	19	44	30.555	41.255	44
20	29.835	40.535	20	45	30.585	41.285	45
21	29.865	40.565	21	46	30.615	41.315	46
22	29.895	40.595	22	47	30.645	41.345	47
23	29.925	40.625	23	48	30.675	41.375	48
24	29.955	40.655	24	49	30.705	41.405	49
25	29.985	40.685	25	50	30.735	41.435	50

TABLE 8

Crystal Frequency and Channel Center Frequency for the 10 kHz Multifilter Receiver

Channel Number	Channel Frequency Number	Channel LO (Crystal Oscillator Frequency)	Channel Number	Channel Number	Channel Frequency Number	Channel LO (Crystal Oscillator Frequency)	Channel Number
1	29.755	40.455	1	26	40.705	30.005	26
2	29.765	40.465	2	27	40.715	30.015	27
3	29.775	40.475	3	28	40.725	30.025	28
4	29.785	40.485	4	29	40.735	30.035	29
5	29.795	40.495	5	30	40.745	30.045	30
6	29.805	40.505	6	31	40.755	30.055	31
7	29.815	40.515	7	32	40.765	30.065	32
8	29.825	40.525	8	33	40.775	30.075	33
9	29.835	40.535	9	34	40.785	30.085	34
10	29.845	40.545	10	35	40.795	30.095	35
11	29.855	40.555	11	36	40.805	30.105	36
12	29.865	40.565	12	37	40.815	30.115	37
13	29.875	40.575	13	38	40.825	30.125	38
14	29.885	40.585	14	39	40.835	30.135	39
15	29.895	40.595	15	40	40.845	30.145	40
16	29.905	40.605	16	41	40.855	30.155	41
17	29.915	40.615	17	42	40.865	30.165	42
18	29.925	40.625	18	43	40.875	30.175	43
19	29.935	40.35	19	44	40.885	30.185	44
20	29.945	40.645	20	45	40.895	30.195	45
21	29.955	40.655	21	46	40.905	31.205	46
22	29.965	40.665	22	47	40.915	31.215	47
23	29.975	40.675	23	48	40.925	31.225	48
24	29.985	40.685	24	49	40.935	31.235	49
25	29.995	40.695	25	50	40.945	31.245	50

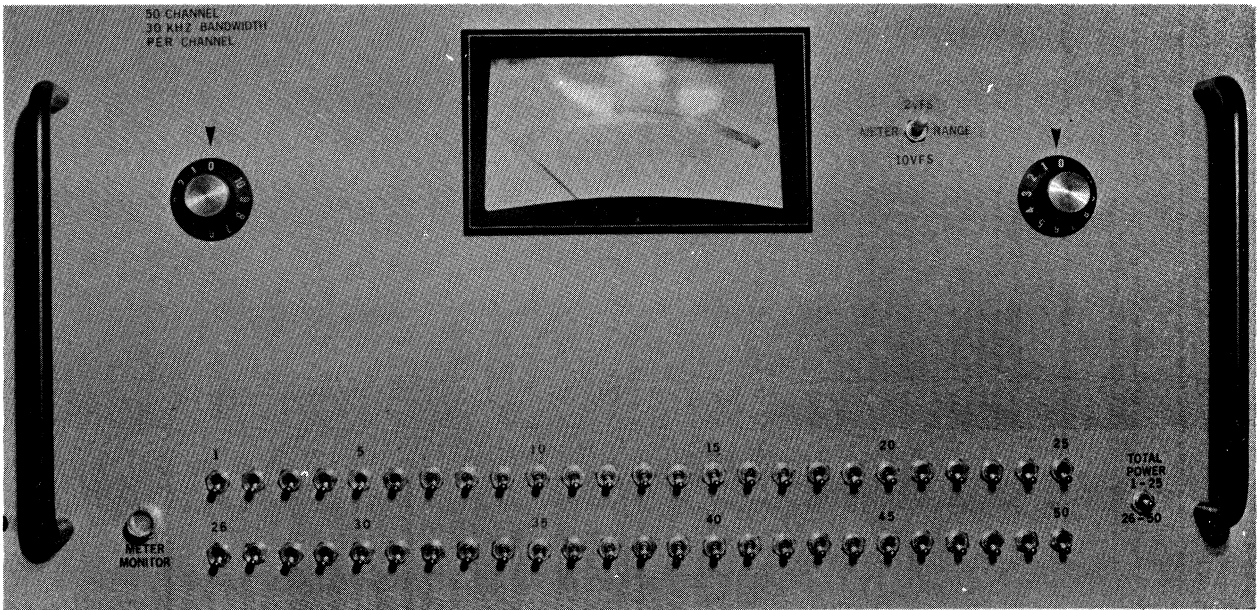

Front Panel of 50-Channel 30 kHz Receiver

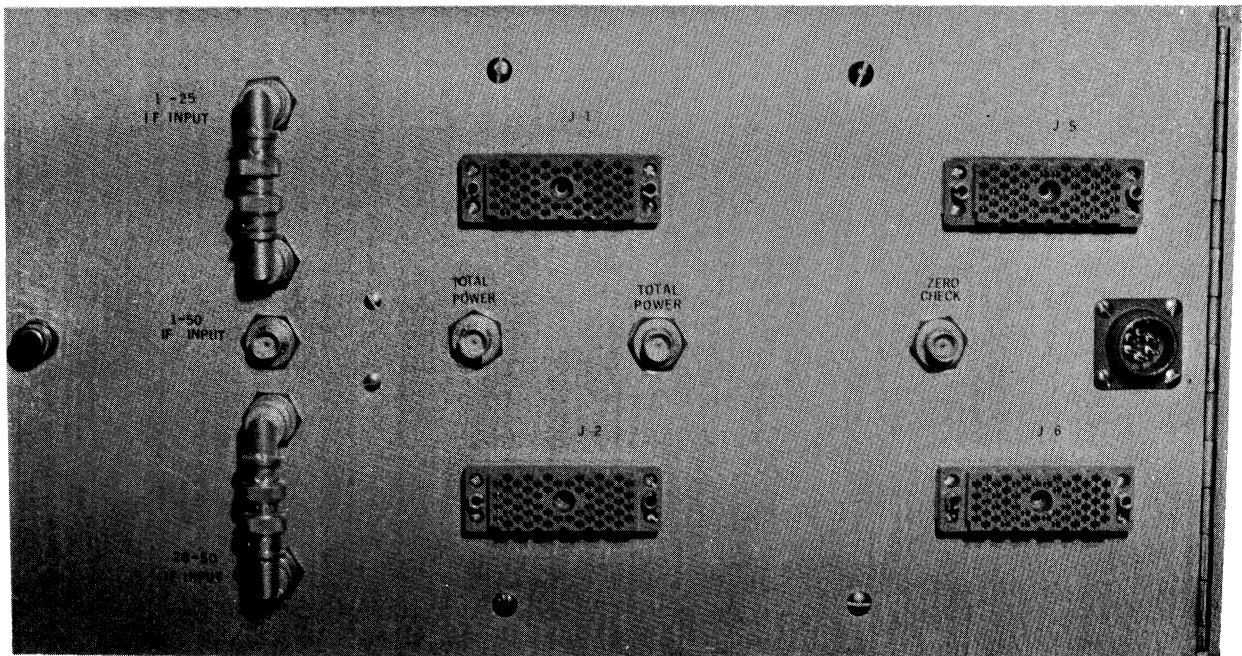

Back Panel of 50-Channel 30 kHz Receiver

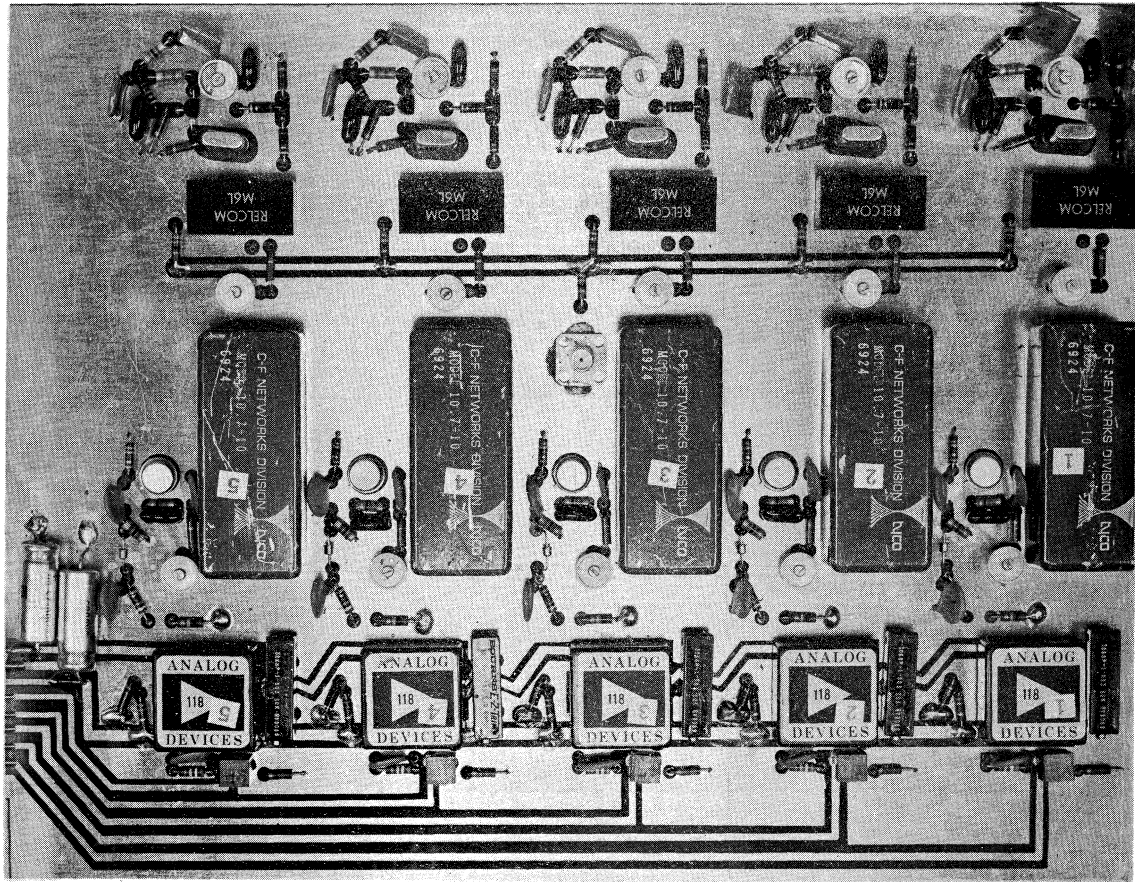

6219

Top View of 30 kHz and 10 kHz Printed Circuit Board

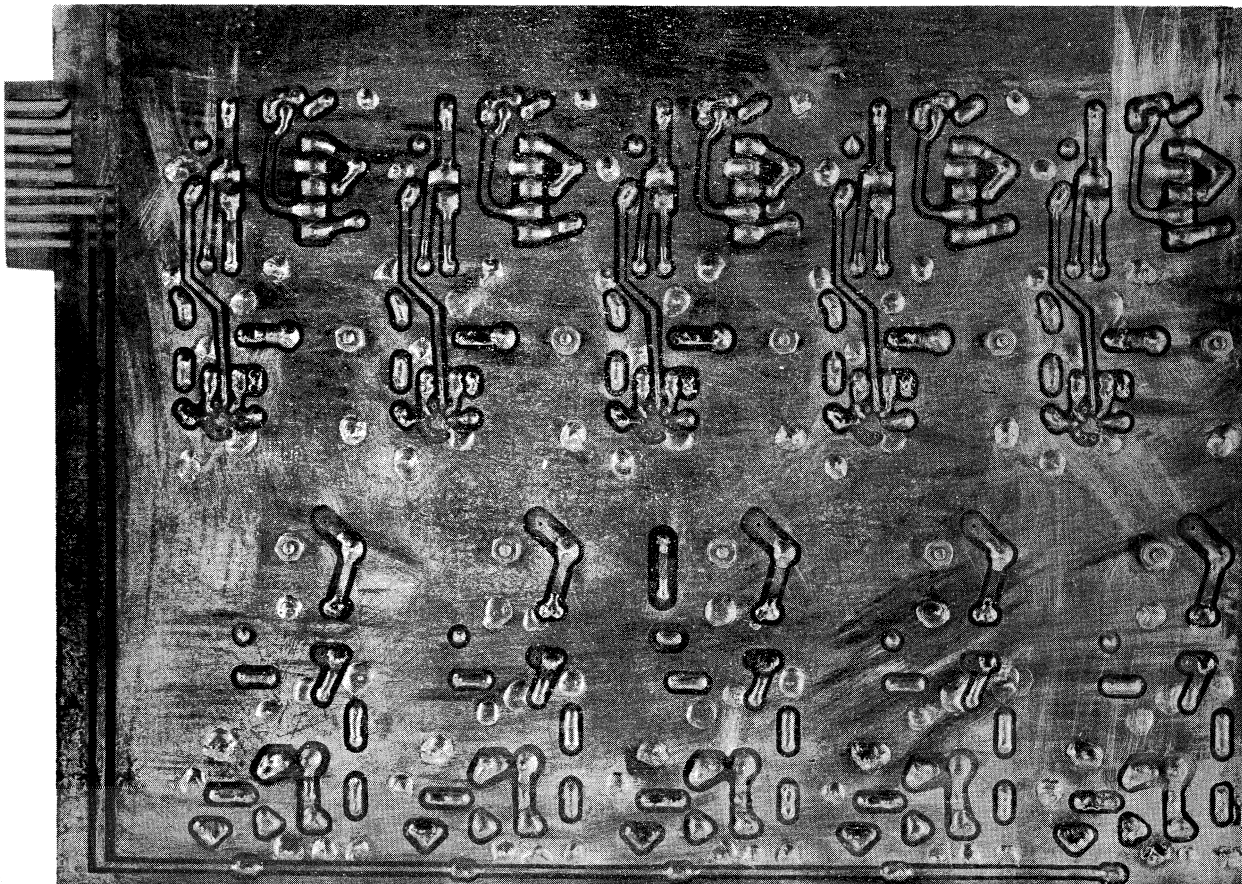

6220

Bottom View of 30 kHz and 10 kHz Printed Circuit Board