

NATIONAL RADIO ASTRONOMY OBSERVATORY  
Green Bank, West Virginia

Electronics Division Internal Report No. 82

NRAO UNIVERSAL LOCAL OSCILLATOR

M. Balister

OCTOBER 1968

NUMBER OF COPIES: 100

# NRAO UNIVERSAL LOCAL OSCILLATOR

M. Balister

## TABLE OF CONTENTS

	<u>Page</u>
1. General .....	1
2. Synthesizer-Frequency Controller .....	2
3. Multiplier Unit .....	3
4. Universal Local Oscillator Installation .....	4
5. Operation of the Universal Local Oscillator .....	5
6. Noise Performance .....	7

## LIST OF FIGURES

Figure 1 — Photograph of the Universal Local Oscillator .....	8
Figure 2 — Block Diagram of the Universal Local Oscillator ...	9
Figure 3 — Control Unit for Hewlett Packard Synthesizer .....	10
Figure 4 — DP 3000 Circuit Board .....	11
Figure 5 — Switch Position Digital Readout to Computer .....	12
Figure 6 — Sweeper Circuit .....	13
Figure 7 — Multiplier Unit Circuit Diagram .....	14
Figure 8 — Multiplier Unit — Printed Circuit Board .....	15
Figure 9 — Spectrum of RF Output .....	16

## NRAO UNIVERSAL LOCAL OSCILLATOR

M. Balister

### General

The NRAO Universal Local Oscillator (ULO) is designed to give any output frequency in the range 1-2 GHz with an accuracy of better than 1 part in  $10^8$ . The system is built around a Hewlett Packard 500 MHz synthesizer which can be remotely controlled to switch between signal and comparison frequencies. A power amplifier with a frequency range 240-300 MHz drives a frequency multiplier, the output cavity of which can be tuned to any frequency in the range 1-2 GHz. The actual multiplication used depends on the output frequency desired; the following table demonstrates this.

Synthesizer Output Frequency - MHz	Multiplier Ratio	Multiplier Output Frequency - MHz
240-300 .....	4	960-1200
240-300 .....	5	1200-1500
240-300 .....	6	1440-1800
240-300 .....	7	1680-2100

The multiplier generally gives at least 100 mW at the output terminal on the rack at all of these multiplication ratios. This is sufficient to drive most of the NRAO front ends which operate in the 1-2 GHz frequency range.

A 1 watt TWT is incorporated in the LO and may be used to drive higher frequency receivers that require more power than is available from the multiplier.

A photograph of the system is shown in Figure 1; the block diagram is shown in Figure 2. Three of these LO systems have been built. Two will be permanently installed at the 140-foot and 300-foot telescopes and the third is for laboratory and emergency use.

## 2. Synthesizer and Frequency Controller

The Hewlett Packard 5105A Frequency Synthesizer and 5110B driver form the basis of the local oscillator. The driver unit contains a temperature stabilized 1 MHz quartz crystal with an aging rate of less than  $\pm 3$  parts per  $10^9$  per 24 hours. The frequency selection is via front panel push-buttons or by remote switch closure and may be in steps of 100 MHz, 10 MHz down to 0.1 Hz. A search oscillator provides continuous variable frequency selection with an incremental range of 1.0 Hz through 10 MHz. Manual or external voltage control is possible.

The remote frequency controller has three adjustable thumbwheel dials for setting the required signal and comparison frequencies. These are designated  $F_1$ ,  $F_0$  and  $F_2$ .  $F_0$  is the signal frequency and  $F_1$  and  $F_2$  are the comparison frequencies. Normally,  $F_1 = F_2$  but it may be sometimes desirable to switch the comparison frequency alternately above and below  $F_0$ , for example,  $F_1 = F_0 + F_2 = F_0 - F_1 = F_0$ , etc. The thumbwheel switch positions may be read and recorded by the DDP-116 computer and the 140-foot and 300-foot telescopes.

The input reference signal (0 V signal and -6 V reference) drives three DI-20 digital modules. (See Figure 3.) Each circuit consists of a 2-input gate, followed by a transistor inverter amplifier. When all inputs are -6 V the gate turns the transistor on, and the output is clamped through the transistor to zero volts. When any input goes to 0 V the transistor is turned off, and the output falls to the clamp voltage of -6 volts. The center ( $F_0$  line) DI-20 circuit drives another which in turn drives a FA-20 flip-flop circuit whose outputs are connected to the alternate DI-20 inputs (in  $F_1 F_2$  lines). This ensures that  $F_1$  and  $F_2$  are selected alternately when the reference input switches to -6 V. A wafer switch is included so that the local oscillator can be switched manually to  $F_1$ ,  $F_0$  and  $F_2$ ; this is useful for system testing of the radiometer. An LD-30 followed by a DP-3000 (homemade, Figure 4) applies -12.6 volts to the digits selected by the thumbwheel switches. Three more LD-30 circuits drive display lights which show which frequency is selected. The synthesizer is capable of changing frequency in  $20 \mu s$ ; the external control circuits will increase this figure somewhat. However, the switching speed is considerably faster than necessary.

The thumbwheel switches have, in addition to the decade switches which are used to control the synthesizer, digital readouts which are used to record frequency with the computer (Figure 5). Since the computer can read a maximum of 16 bits, the switches have to be read sequentially in a total of six steps. All 10 digits of  $F_0$  are read but only six are read for  $F_1 F_2$  since these are of less importance. The position of the mode switch is also read. The input connections to the first DI circuit are shown in full — the other 15 are not shown to avoid confusion. The inputs are listed in Figure 5.

A sweeper is incorporated on a separate panel to enable one or more of the synthesizer decades to be continuously swept at a rate 3-30 Hz. The circuit and output waveforms are shown in Figure 6. The supply voltages are obtained from the synthesizer control unit.

### 3. Multiplier Unit

The multiplier unit (Figure 7) accepts an input in the frequency range 240-300 MHz and converts this to a frequency in the range 1-2 GHz. The conversion is performed by a wide-range tunable multiplier (Resdel Engineering Corp., XV-900/2500). This multiplier is designed to take a maximum input of 5 watts in the frequency range 150-300 MHz. Harmonic outputs in the frequency range 900-2500 MHz can be selected using a 3-cavity tunable filter. The output power is in the range up to 500 mW when driven at the maximum input level of 5 watts. The multiplier is driven by a broadband transistor power amplifier (Microwave Power Devices, 270-60-5-1M) which covers the desired 240-300 MHz range of input frequencies. The amplifier requires approximately 0 dBm input for 5 watts output. The input power to the multiplier is monitored by means of a 50 dB directional coupler and HP 423 detector. An operational amplifier circuit (Figure 8) drives a 0-100  $\mu$ A meter which is scaled to read 0-10 watts. The variable resistor in series with the input is adjusted to get the best square law response (reading proportional to power) and the adjustable feedback resistor sets the correct gain. The RF output is monitored in a similar manner.

The output of the LO system may be adjusted or levelled using an HP 3505 variable diode attenuator. The output power level can be boosted to greater than

1 watt by switching in via RF switches a HP 489A Microwave Amplifier (TWT). A tunable filter with 5 percent bandwidth follows the TWT in order to remove noise and spurious signals that may be present in the output. A 20 dB coupler is incorporated in the output line to provide a convenient point to monitor the RF output. Two circulators are incorporated, one between the multiplier and diode attenuator and the other is between the tunable filter and TWT (if used).

The front panel has a 3-position wafer switch; the output power is un-levelled in position 1. The power level is varied in this position by adjusting the power control potentiometer (maximum output = 10 V); the leveller amplifier (Figure 7) is connected as a unity gain amplifier by S1A. The maximum diode current available is 5 mA (25 dB) and is sufficient provided the multiplier output is maintained below about 100 mW when used in conjunction with the TWT amplifier.

Position 2 is the local level position. The output power monitor circuit provides a voltage ( $10 \text{ V} \equiv 1 \text{ watt}$ ) which feeds the summing junction of the leveller amplifier (connected as integrator) shown in Figure 7. A back-off is supplied to the same point by the power control potentiometer. The output power can be read off the power control potentiometer  $100 \equiv 1 \text{ watt}$ .

Position 3 uses an external voltage — usually a mixer crystal current monitor for levelling the output power. The mixer current monitors (max. 10 V) are brought into the top of the LO rack, and can be read off a front panel meter on the multiplier unit. One of them drives a unity gain differential amplifier, the output of which drives the leveller circuit.

A "levelled" light indicates when the output power is levelled. The driving circuit consists of a RCA CA 3000 integrated DC amplifier which senses when the HP 3505 diode is conducting (i. e., attenuating). When the current drops to zero, the levelled light is extinguished.

Two Lambda LH 125 FM power supplies power the multiplier unit.

#### 4. Universal Local Oscillator Installation

The ULO is expected to become part of the permanent telescope equipment and should remain in position when receivers are changed. There are various top panel connectors which should remain permanently connected to the rest of the receiving system. These connectors are listed below.

- RF output. This is connected via a low loss telescope cable to the LO input on the front-end box.
- Ref input. This signal drives the frequency controller and is normally derived from the autocorrelation receiver or computer if a multichannel filter receiver is to be used (0 V signal, -6 V reference).
- Mixer inputs. These are connected to the front-end equipment rack and enable the mixer crystal currents to be monitored. The input signal should be 5 V/mA crystal current.
- VLB Standard. For programs, e. g. , VLB, that require a better frequency standard than the HP 5110B driver, the required input frequency is 5 MHz.

## 5. Operation of the Universal Local Oscillator

It should be remembered that the ULO is capable of greater than 1 W output power — it is possible under some circumstances that this could damage the mixer crystals if care is not taken.

The 10 dB line loss which exists at the 140-foot and 300-foot telescopes will protect most receivers. It is suggested that a 10 dB fixed attenuator be used between ULO and front-end in the laboratory.

In order to tune up the ULO, the following steps should be followed:

- 1) Ensure that there is 115 V applied to rack. Turn on both synthesizer units and the two Lambda power supplies. The TWT should be off and the TWT switch on the Multiplier Unit should be OUT.

Set  $F_1$ ,  $F_2$  and  $F_0$  on the Frequency Controller Unit to be the required frequencies, and turn selector switch to  $F_0$  position. The REMOTE/LOCAL switch on the synthesizer should be in REMOTE. The RF output control on the synthesizer should be adjusted

so that the multiplier input power meter reads 4-5 watts. Set switch on Multiplier Unit to OPEN LOOP position and power control fully clockwise.

- 2) Set the multiplier micrometer to within 25 MHz of the required LO frequency. (See chart with ULO.) The tunable filter should be set within 10 MHz of the required frequency. Tune the MATCH and TUNE knobs close to the synthesizer output frequency. An output should be observed on the 0-100 mW range of the output power meter. When this occurs the six tuning adjustments should be optimized, taking care to avoid applying an excessive power to the receiver mixer. It may be necessary to use the power control to decrease the output.
- 3) When tuning is accomplished, the output may be levelled internally or externally. The power control should be set to the approximate required power (100 = 1 watt) and then the switch can be tuned to the required levelled position. The mixer current can then be set to the required level with the power control.  
  
When frequency switching, it is important to ensure if either of the "levelled" modes is used that the output power is levelled at  $F_1$ ,  $F_2$  and  $F_0$ . If not, some further tuning of the multiplier may be required. The bandwidth is sufficient to allow switching  $\pm 5$  MHz in the range 1-2 GHz, unless the output power is marginal. If this is the case, the TWT will have to be used.
- 4) It is important to note that tuning the multiplier in the levelled configuration can only be done by noting the attenuator current, i. e. , measured power out is compensated by more current (attenuation). This can only be satisfactorily done if there is a reasonable current  $\geq 0.5$  mA.



A final test which should be done is to confirm that there is sufficient power margin when running levelled. This can be checked by increasing the power control by 10-20 percent; the levelled light should not go out.

## 6. Noise Performance

The power output has exhibited no spurious output signals when the multiplier is correctly tuned, i. e. , all six adjustments optimized for maximum power output.

Harmonically related frequencies are at least 80 dB down on the desired output. The noise sidebands close in to the carrier are at least 60 dB down on an HP 8551B spectrum analyzer (Figure 9). No deterioration in mixer noise figure has been observed in the 1-2 GHz frequency range.

When the output power is multiplied by 6 to X-band (10.545 GHz), a considerable proportion of the output power is in the sidebands (10 percent or more). The highest frequencies used for VLB and line work from the ULO (with extra multiplication in receiver) have been 5000 MHz and  $\approx$  9000 MHz. The noise sidebands did not interfere seriously with the experiments at either of these frequencies. The noise sidebands which become more obvious on multiplication result from the noise sidebands on the synthesizer output. For higher frequency requirements where the noise may well be troublesome, one solution could be to phase lock a VCO cavity oscillator operating in the frequency range 240-3000 MHz to the synthesizer output. One test which was made to verify this consisted of replacing the synthesizer with a 3200B oscillator. The output spectrum at 10.545 GHz showed no evidence of noise sidebands using the HP spectrum analyzer.

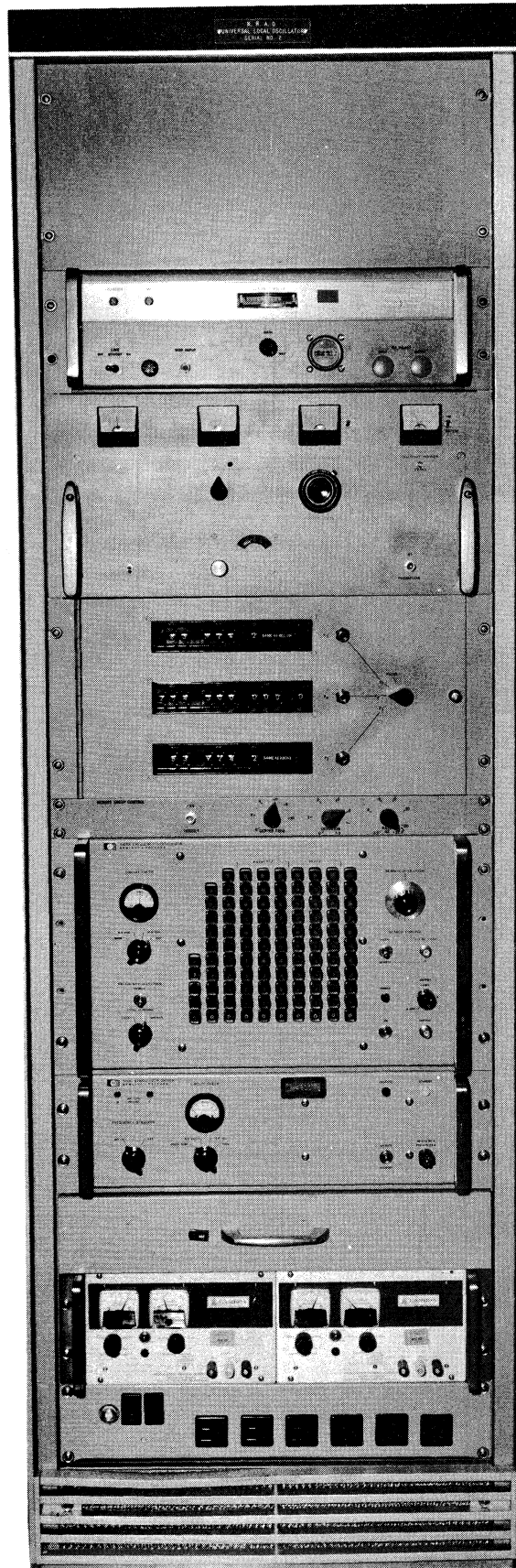
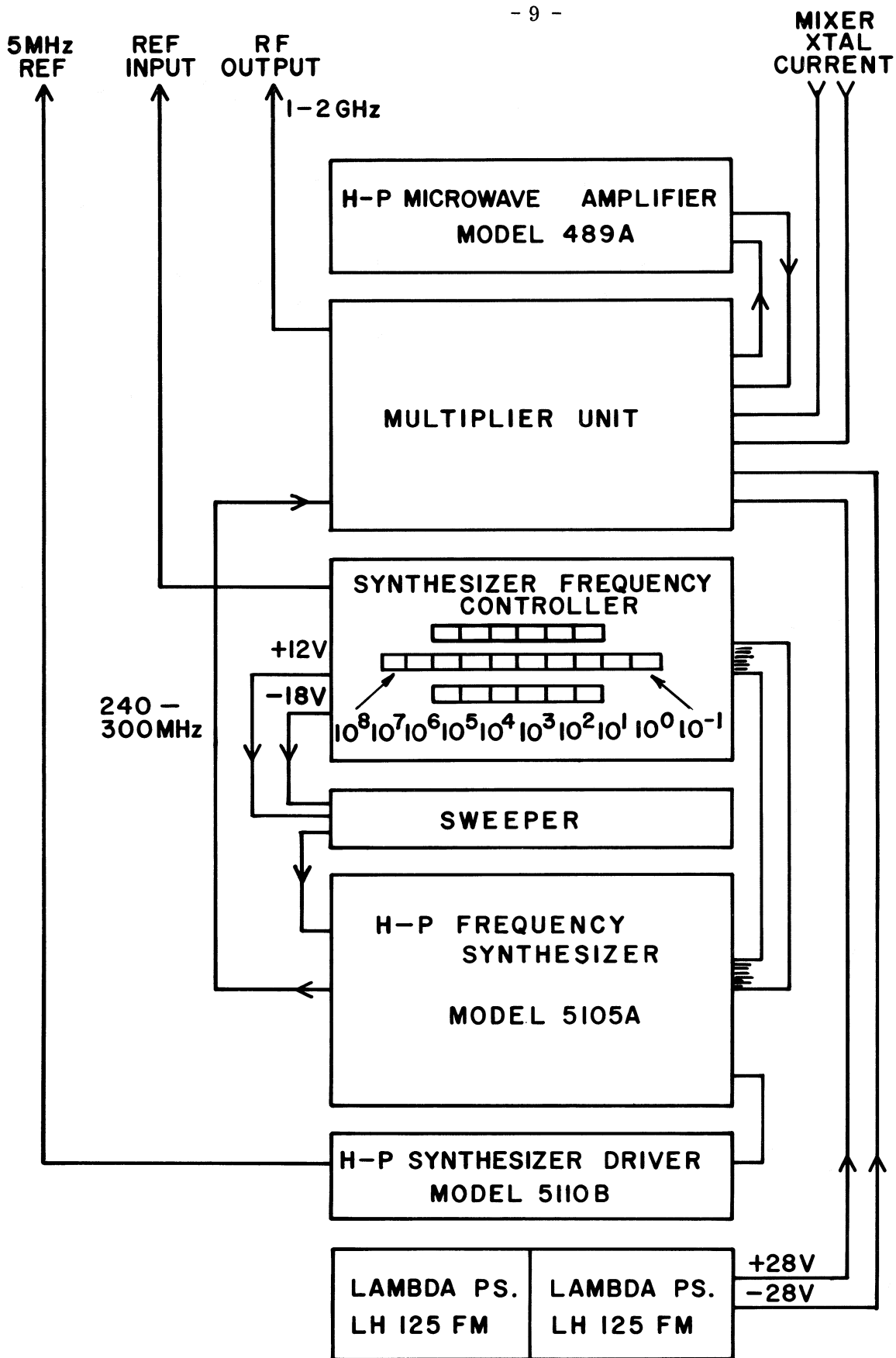
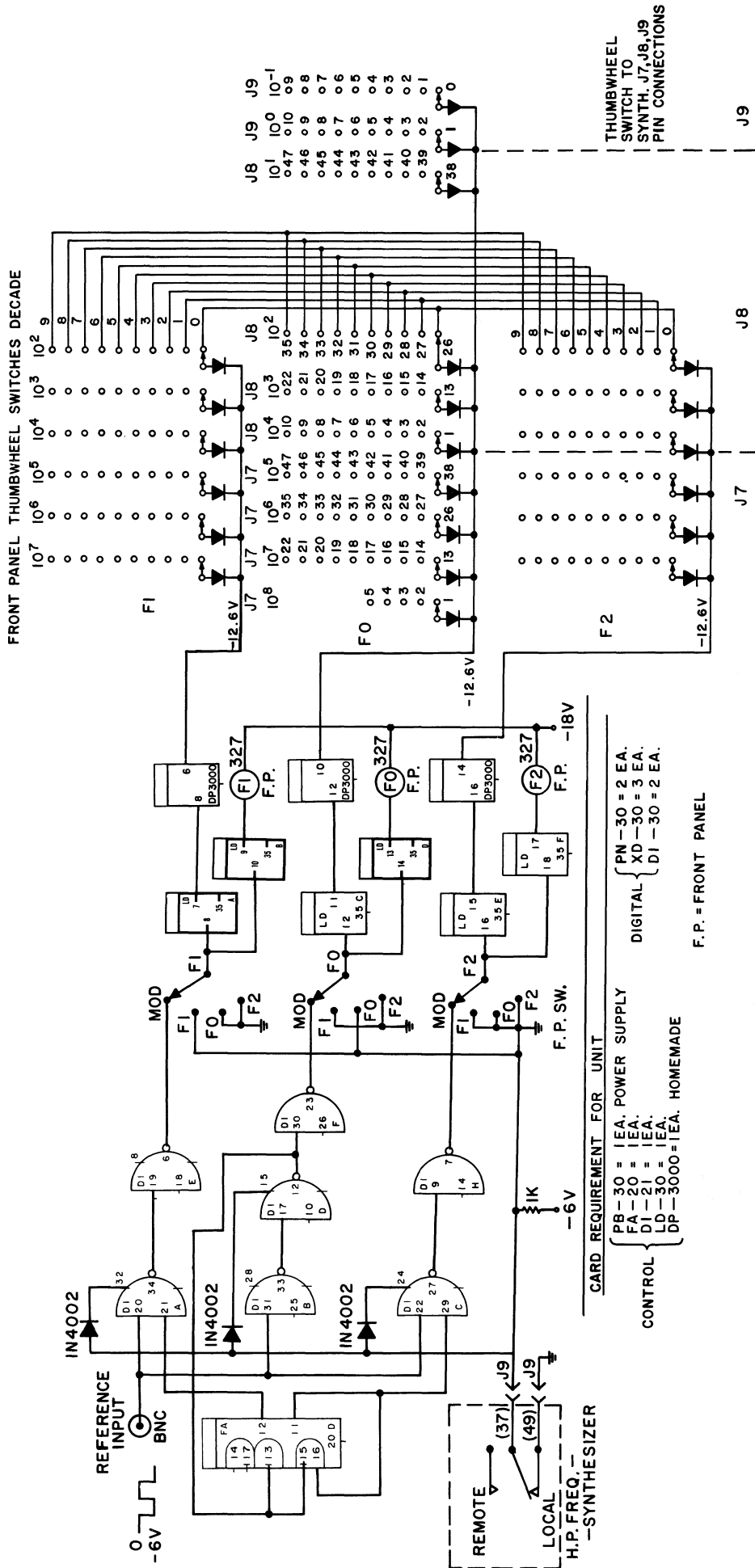

Figure 1



BLOCK DIAGRAM OF UNIVERSAL LOCAL OSCILLATOR  
FIG. 2



CONTROL UNIT FOR H.P. SYNTHESIZER

FIG. 3

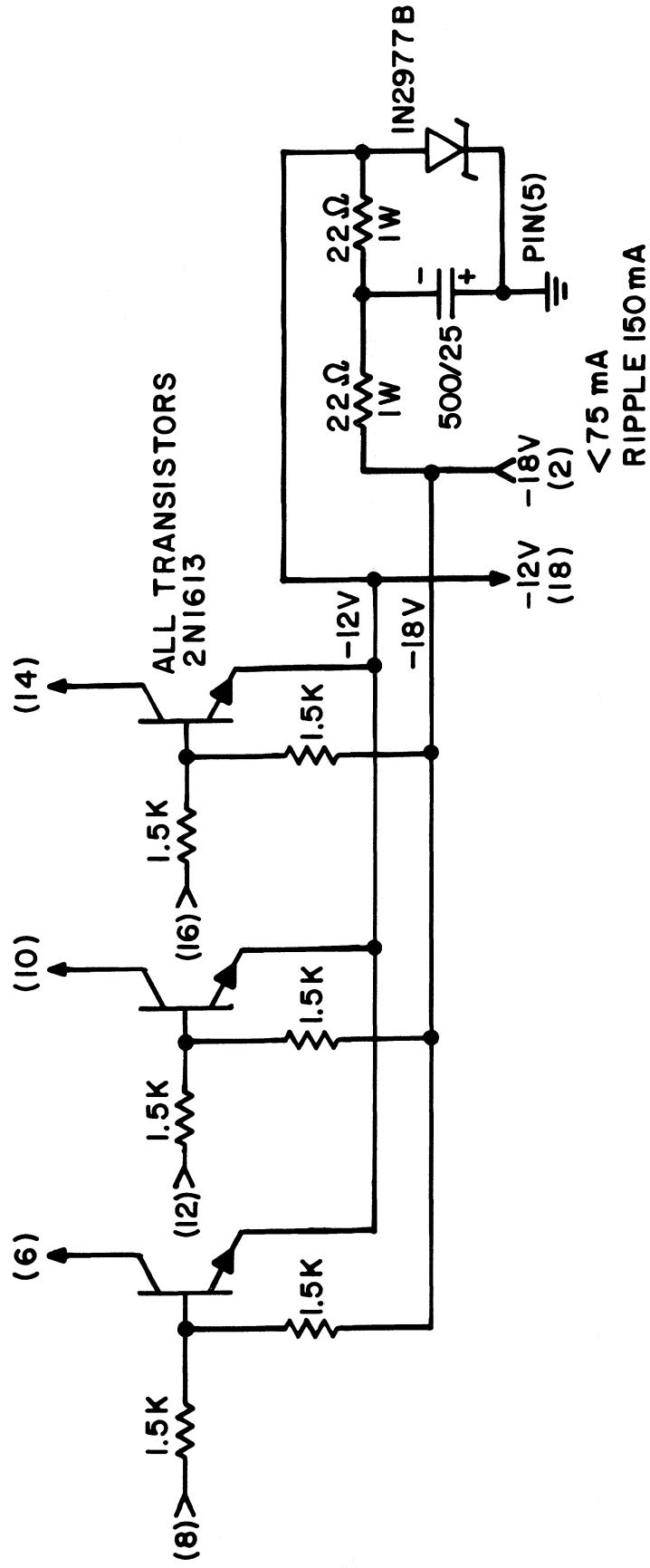

DP 3000 CIRCUIT BOARD

FIG. 4

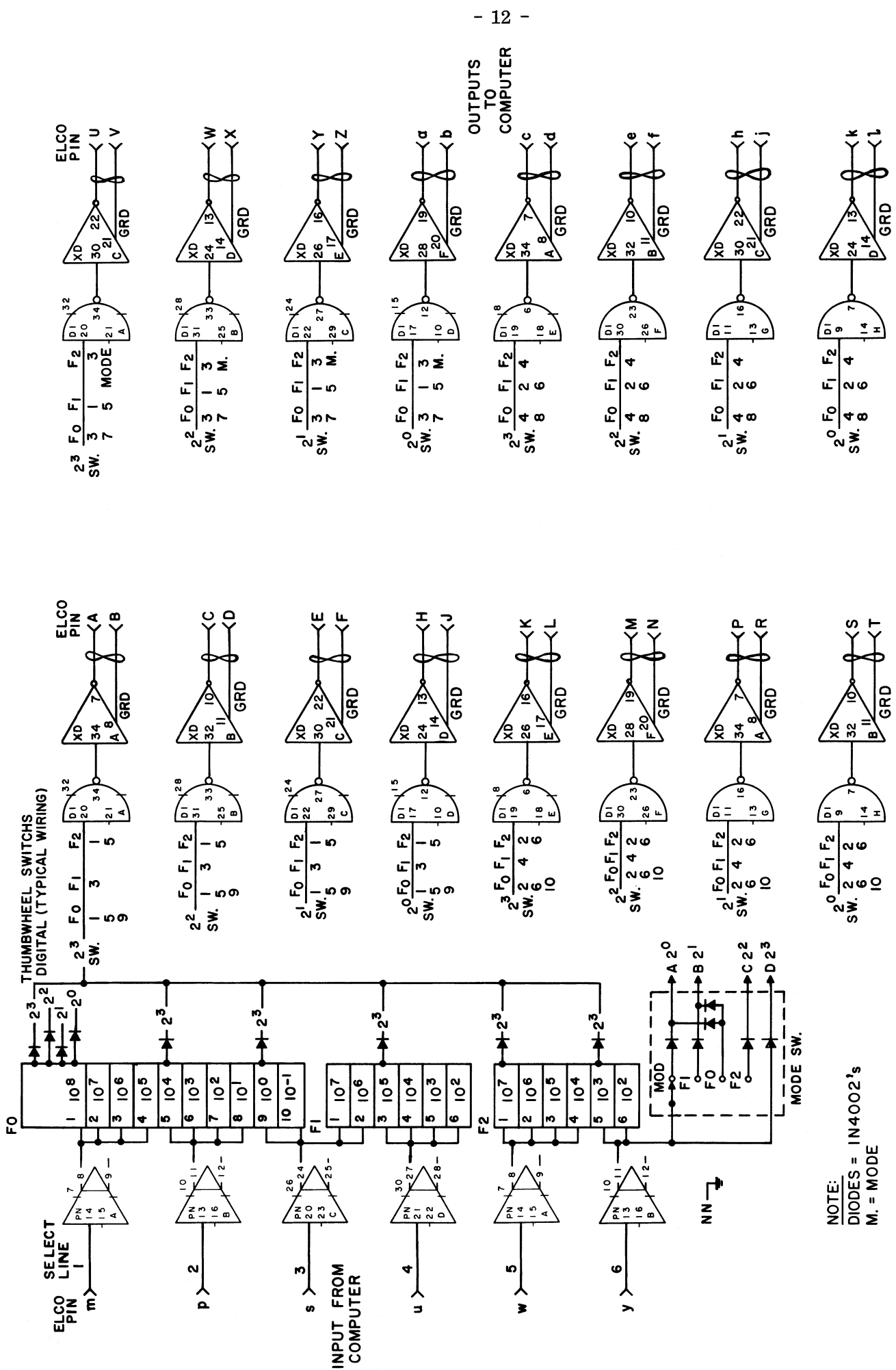

SWITCH POSITION DIGITAL READOUT TO COMPUTER

FIG. 5

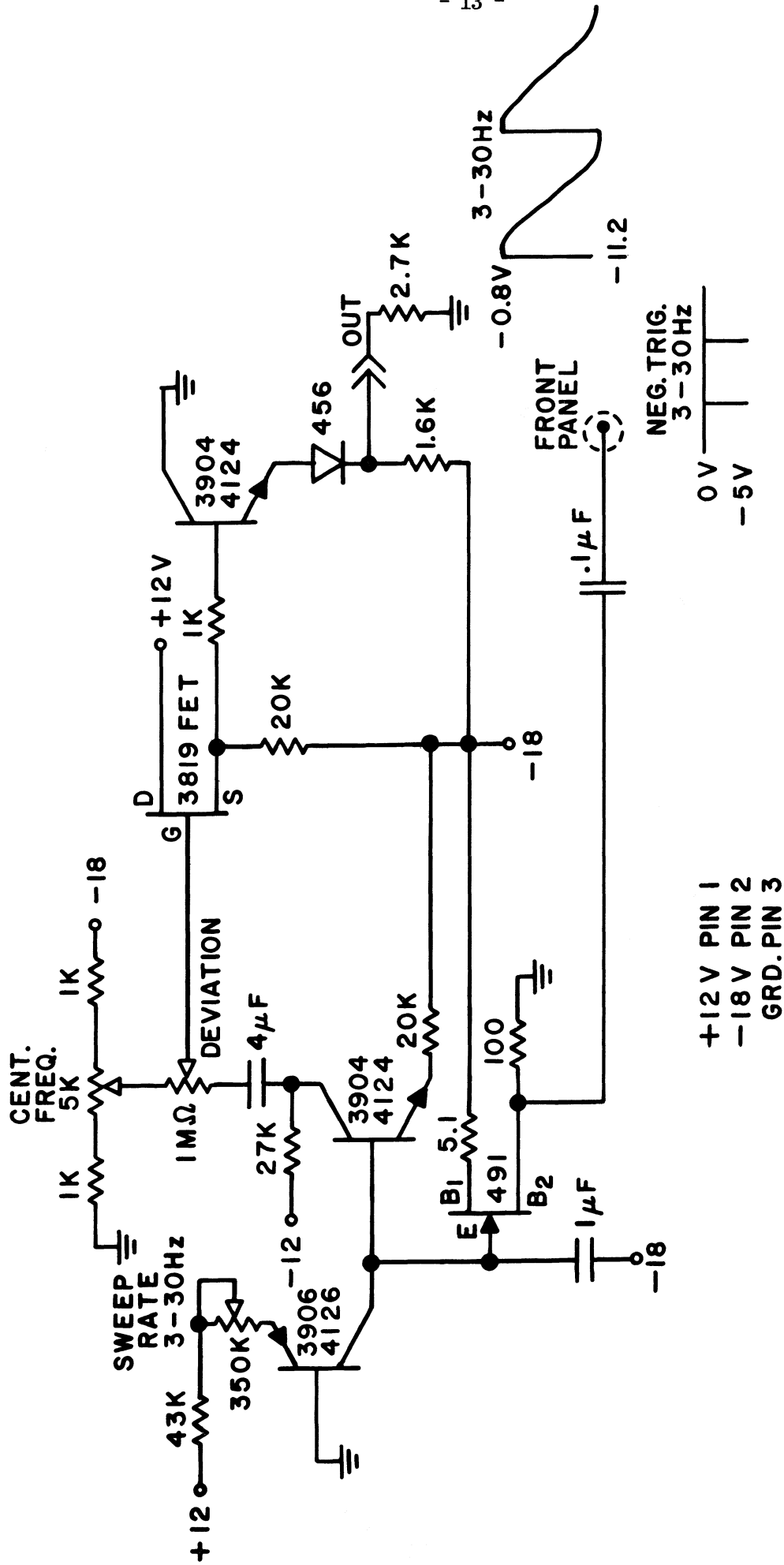

SWEEPER CIRCUIT  
FIG. 6

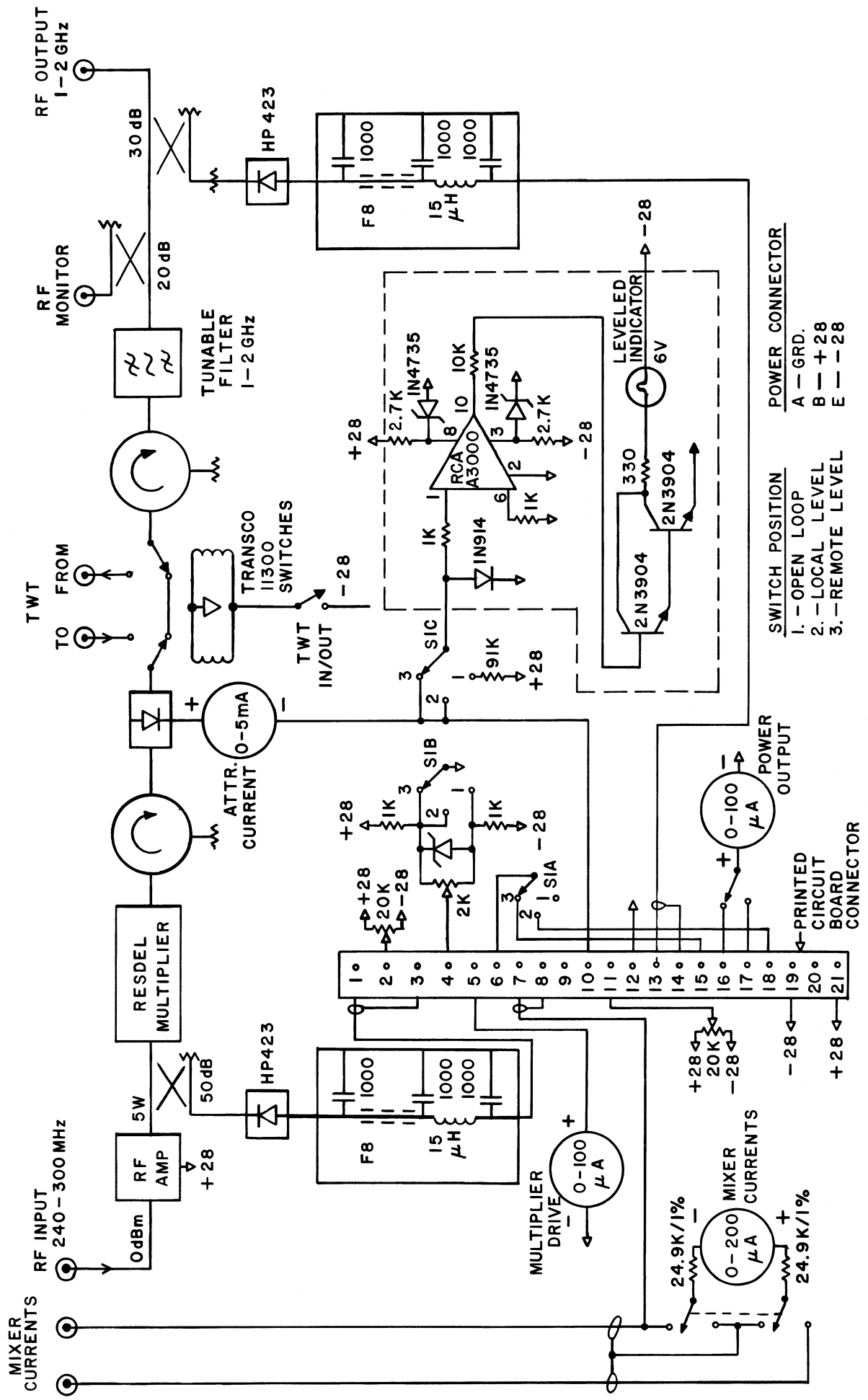

MULTIPLIER UNIT CIRCUIT DIAGRAM

FIG. 7

- SWITCH POSITION**
- 1. - OPEN LOOP
  - 2. - LOCAL LEVEL
  - 3. - REMOTE LEVEL
- POWER CONNECTOR**
- A - GRD.
  - B - +28
  - E - -28





Vertical: 10 dB/cm

Horizontal: 30 MHz/cm

IF Bandwidth: 100 kHz

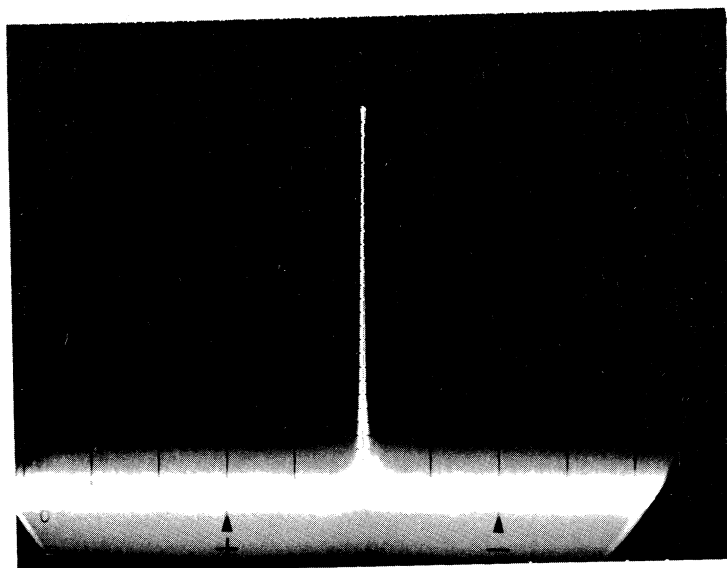

FIGURE 9  
SPECTRUM OF RF OUTPUT