

NATIONAL RADIO ASTRONOMY OBSERVATORY  
Green Bank, West Virginia

Electronics Division Internal Report No. 60

PERFORMANCE OF NARROWBAND 9mm RADIOMETER

Rama C. Menon  
Neil Albaugh and Donald Logan

May 1967

## 1. Description of the System

It is customary to separate the components of radiometer into two groups and designate them as "front end" and "back end". The "front end" consists of the Dicke switch, local oscillator, mixer and IF preamplifier. The "back end" of the radiometer refers to the section after the intermediate frequency. Figures 1 and 2 show the block diagrams of the front and back end of 9mm narrow band radiometer. This is basically a Dicke switched superhet system with no rf amplification.

The radiometer can switch with a ferrite device between the feedhorn and comparison channel which can be selected to be either an offset feedhorn or an ambient temperature termination. Comparison channel inputs are selected by a remotely controlled Ramcor waveguide switch. For versatility in beam switching techniques, the two feed horns can be physically separated by 3, 4 and 5 cms (corresponding to 3, 4 and 5 of 36 ft HPBW separation) by using different waveguide bends between the solenoid switch and the offset feedhorn. The isolator minimizes the load mismatches as seen by the mixer.<sup>1</sup> The IF output from the mixer preamp is transmitted to the IF post amplifier detector and associated signal processing circuits in the back end via 50 ohm co-axial cable. There is no broadband gain modulator in the present system.

Sander Weinreb has designed a more versatile standard back end incorporating operational amplifiers, which will be used later in conjunction with present front end. For completeness the new standard back end block diagram is shown in Figure 3. Here one has the choice to use either the IF gain modulator or a post detection DC gain modulator. A bandpass of DC to 1 KC is used between the square law detector and the synchronous detector, thus covering a wide range of switch frequencies and increasing the radiometer sensitivity by 11% (since

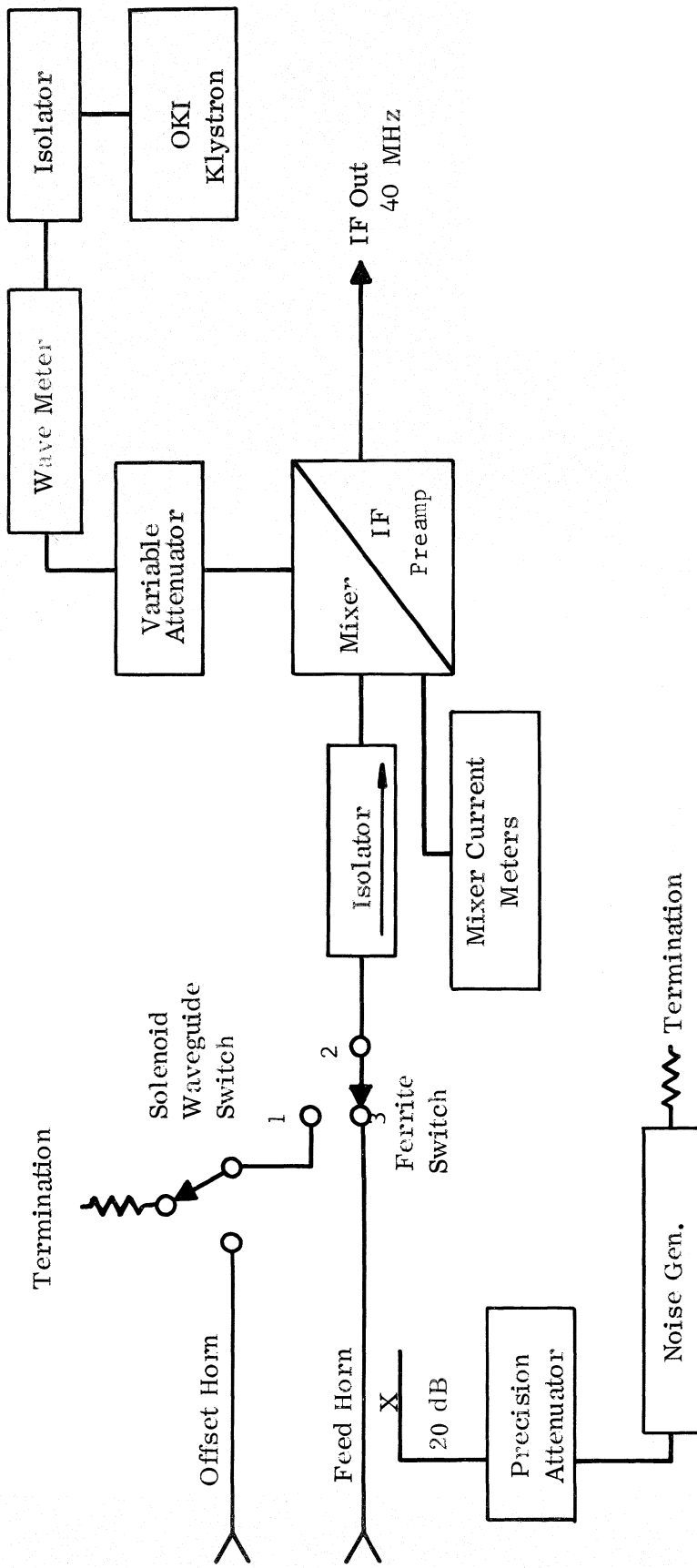

FIG. 1. 9.5 mm RECEIVER FRONT END

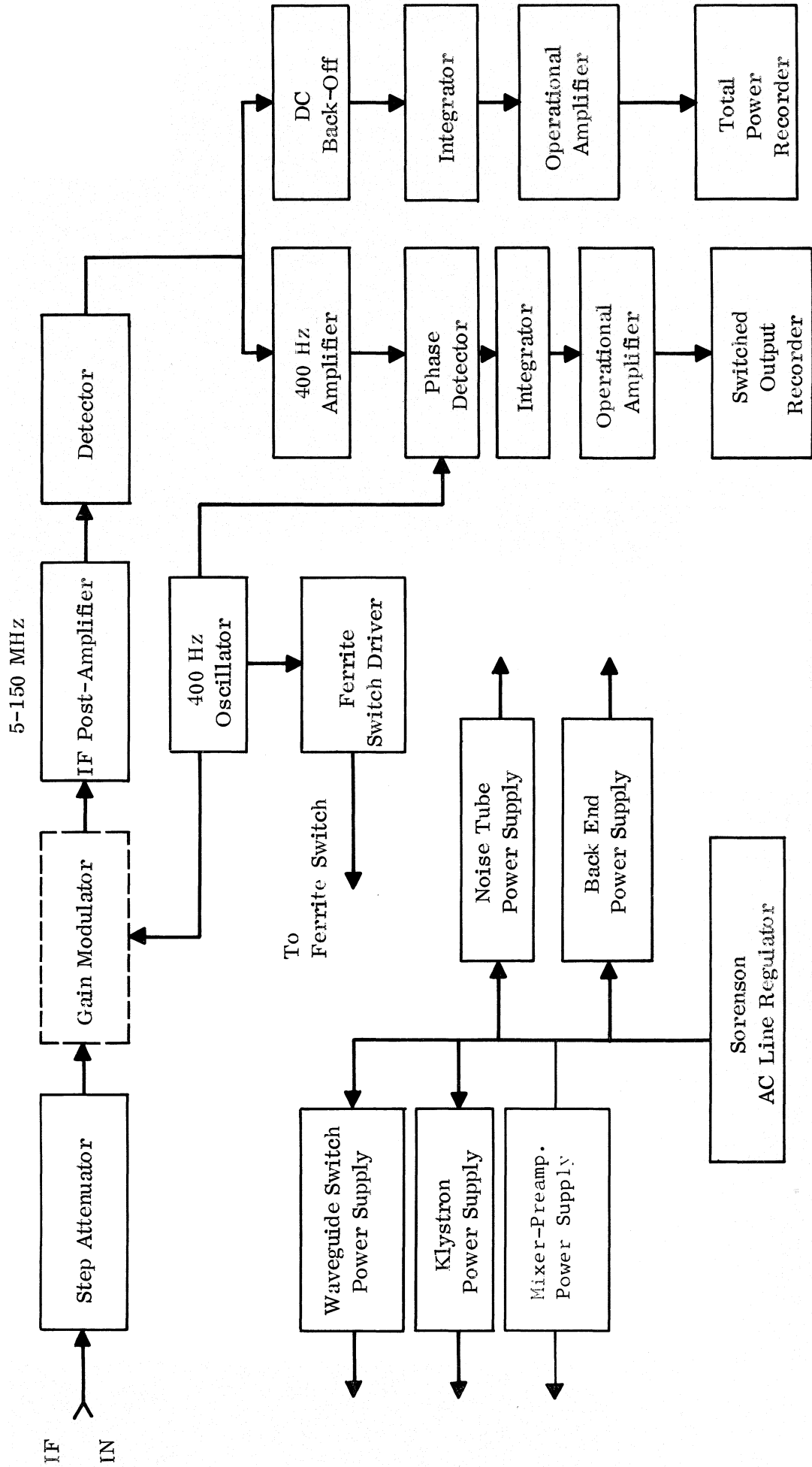

FIG. 2. RECEIVER BACK END

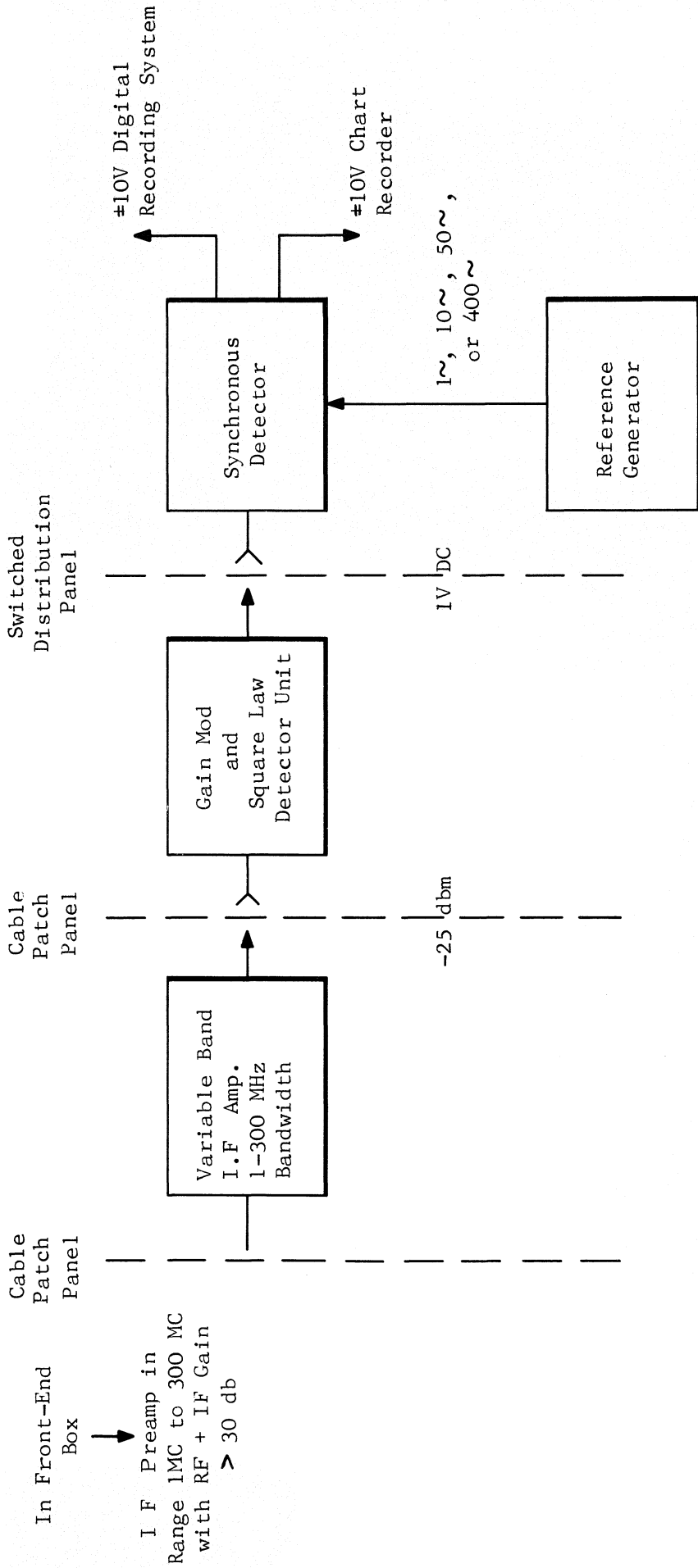

FIG. 3. STANDARD RECEIVER CONTROL ROOM CONFIGURATION

higher switch harmonics will be included). This wide dynamic range also is expected to give an accuracy of  $.01^\circ$  at  $100^\circ$  full scale.

## 2. Characteristics of Front End Components

### a. Feedhorns

The feedhorns for the 36 ft (11m) with  $F/D=0.8$  and for the 140 ft (42.7m) with  $F/D=0.43$  are from TRG with maximum gain consistent with a sidelobe level  $\geq 20$ db down the main lobe. TRG feedhorns for 36 ft dish have H-plane feed patterns with an edge taper 10.4 and 10.9 db at an aperture angle  $68^\circ$  and E-plane feed patterns with an edge taper 13.8 and 14.0 db at the same aperture angle for both the horns. However, the feed horns are connected to receive one linearly polarized radiation. The sweep vswr measurements over  $31.4 \text{ GHz} \pm 150 \text{ MHz}$  agree with the specifications (under 1.2) as shown in Table I (S.No. stands for serial number).

TABLE I. Measured VSWR of TRG Feed Horns

<u>FREQUENCY</u>	<u>MEASURED VSWR</u>				
		A894-25 (36 ft)		S318-12 (140 ft)	
GHz	S.No. 1	S.No. 2	S.No.1	S.No. 2	
31.2	1.05	1.035	1.106	1.07	
31.3	1.055	1.03	1.12	1.09	
31.4	1.06	1.04	1.13	1.10	
31.5	1.06	1.05	1.15	1.11	
31.6	~1.06	1.06	1.18	1.125	

### b. Ferrite Switch

The ferrite dicke switch is a four-port ferrotec switch based on the Faraday rotation principle. This unit can be used as a single pole double throw

switch if one port is permanently connected to a termination. The cyclic order of the ports 1, 2, 3, 4 (with "0" dc current) represents the easy propagation path, the reverse direction (with 180 ma) providing isolation. At present, terminals 1 and 3 are used for input and 2 for output with terminal 4 connected to a TRG load. It switches between the two current limits of 0 and 180 dc for off and on conditions. The insertion loss and isolation are measured at each frequency in the band (31.4 GHz  $\pm$  150 MHz) by the substitution method. The listed vswr values are obtained by the slotted line method and agree well with the reflectometer sweep measurements. All the ports other than the one at which measurements were made, are connected to terminations. The average measured values over 31.4 GHz  $\pm$  150 MHz are shown in Table II.

TABLE II. Characteristics of Ferrotec Switch

<u>PORT</u>	<u>Insertion Loss (db)</u>	<u>PORT</u>	<u>Isolation (db)</u>	<u>PORT</u>	<u>VSWR</u>
1-2 (0ma.)	0.4	2-1 (0ma.)	24.2	1	1.2 to 1.24
1-3 (0ma.)			22	2	1.24 to 1.30
3-2 (180ma)	0.5	2-3 (180ma)	24	3	1.14 to 1.25
3-1 (180ma.)			20	From 0 to 180 ma current range	

The Solenoid operated on and off mechanical switch has very low loss (0.2) db and low vswr (< 1.1) in the entire waveguide band.

c. Isolator

The measured values (Table III) of vswr, insertion loss and isolation of the TRG A 110 (s. No. 154) agree with specifications. Sweep measurement showed a resonance in vswr at 31.5 GHz as tabulated.

TABLE III. Measurements on TRG Isolator

<u>Frequency</u> (GHz)	<u>VSWR</u>	<u>Isolation</u> (db)	<u>Insertion</u> <u>Loss</u> (db)
31.2	1.11	18.0	0.43
31.3	1.13	20.0	0.43
31.4	1.14	22.5	0.43
31.5	1.15 to 1.125	24.0	"
31.6	1.13	25.0	"

#### d. Mixer Preamplifier

The mixer-preamplifier is a custom built unit by the LEL division of Varian Associates. The configuration is a balanced mixer with matched reverse 1N 53 CMR type crystals requiring 1-2 mw local oscillator power. The preamplifier is a multistage transistor amplifier with 50 db gain and with a noise figure of about 3 db. The specified bandwidth is 150 MHz but the measured bandwidth between the 3 db points is only 40 MHz (Fig. 4). The entire unit has a double channel NF of  $12.0 \pm 0.5$  db for optimum local oscillator power injection (crystal currents  $\sim 1.0$  ma dc). The vswr of the mixer was measured at L.0 port (1.18) and signal port, (1.60) for rated crystal current while the other was connected to a load, with a slotted line.

#### 3. IF Bandpass and Detector Response

The entire front end bandpass (Fig. 4) is swept with a sweep generator connected through an attenuator to the feed horn input port. The IF output through a HP 423A detector is fed to an X-Y recorder. The same characteristic curve is redrawn with 3 db pad inserted before the detector to accurately determine the 3db bandwidth. As all the other front end components including the



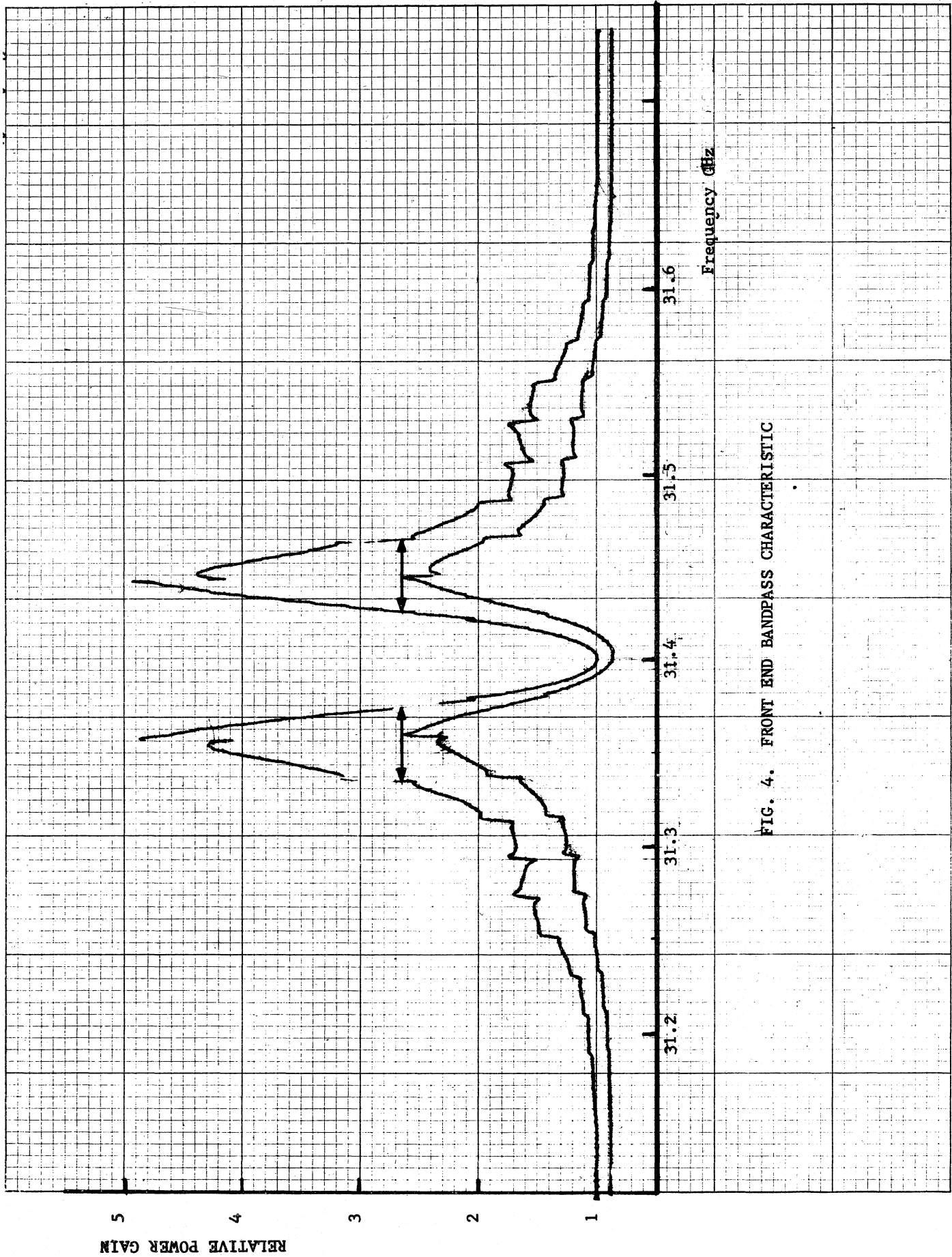

FIG. 4. FRONT END BANDPASS CHARACTERISTIC

ferrite switch have a very large bandwidth, and also from the symmetry of the characteristic around L.O frequency, one can attribute the narrow bandwidth to mixer preamp unit alone. The actual integrated 3 db bandwidth is about 40 MHz. The same front end bandpass has been measured earlier (Fig. 5) with open radiation in the laboratory using a sweep generator and a spectrum analyzer. The characteristic does compare favorably giving an appropriate bandwidth of 45 GHz.

The IF-detector used in the present back-end is a Sylvania IN270 whose measured sensitivity is 0.22 mv/ $\mu$ w. The output voltage is measured with a high impedance voltmeter and the output current measured with a low resistance current meter and these values are plotted as function of IF attenuation (Fig. 6). The characteristic is linear over 8 db input range with a detector law, of 1.62 instead of a square law. However, the range of antenna temperatures at very high frequencies, being at the most of 100:1 ratio, it is not necessary to correct for the lack of square law detector performance. At the extreme even the sun's temperature (same order as radiometer noise) can be measured within the dynamic range of the detector.

#### 4. Radiometer Calibration

An AIL noise tube with about 10,000<sup>o</sup>K (15.28  $\pm$  .25 db above ambient) is used as usual as secondary calibration. This secondary calibration signal is compared with absolute standard calibration<sup>2</sup> from the Adtec loads (77<sup>o</sup> to 373<sup>o</sup>K). In the standard calibration procedure, two calibration loads - one at liquid nitrogen temperature and/or hot water, the other at room temperature - are alternately connected to the radiometer input to provide a known temperature difference (Fig. 7). The hot and cold load calibrations should be repeated several times consecutively to eliminate random measurement errors.

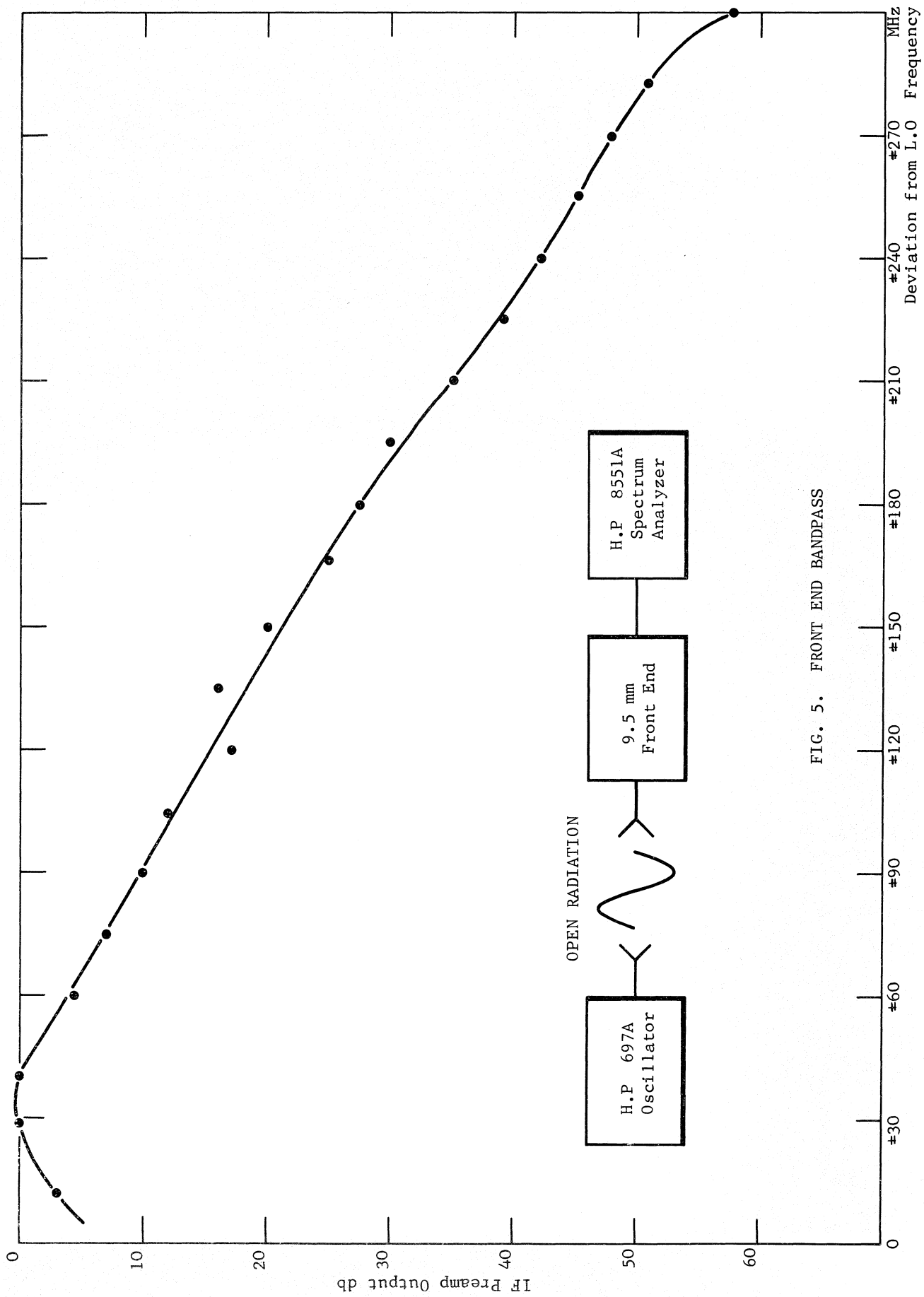

FIG. 5. FRONT END BANDPASS

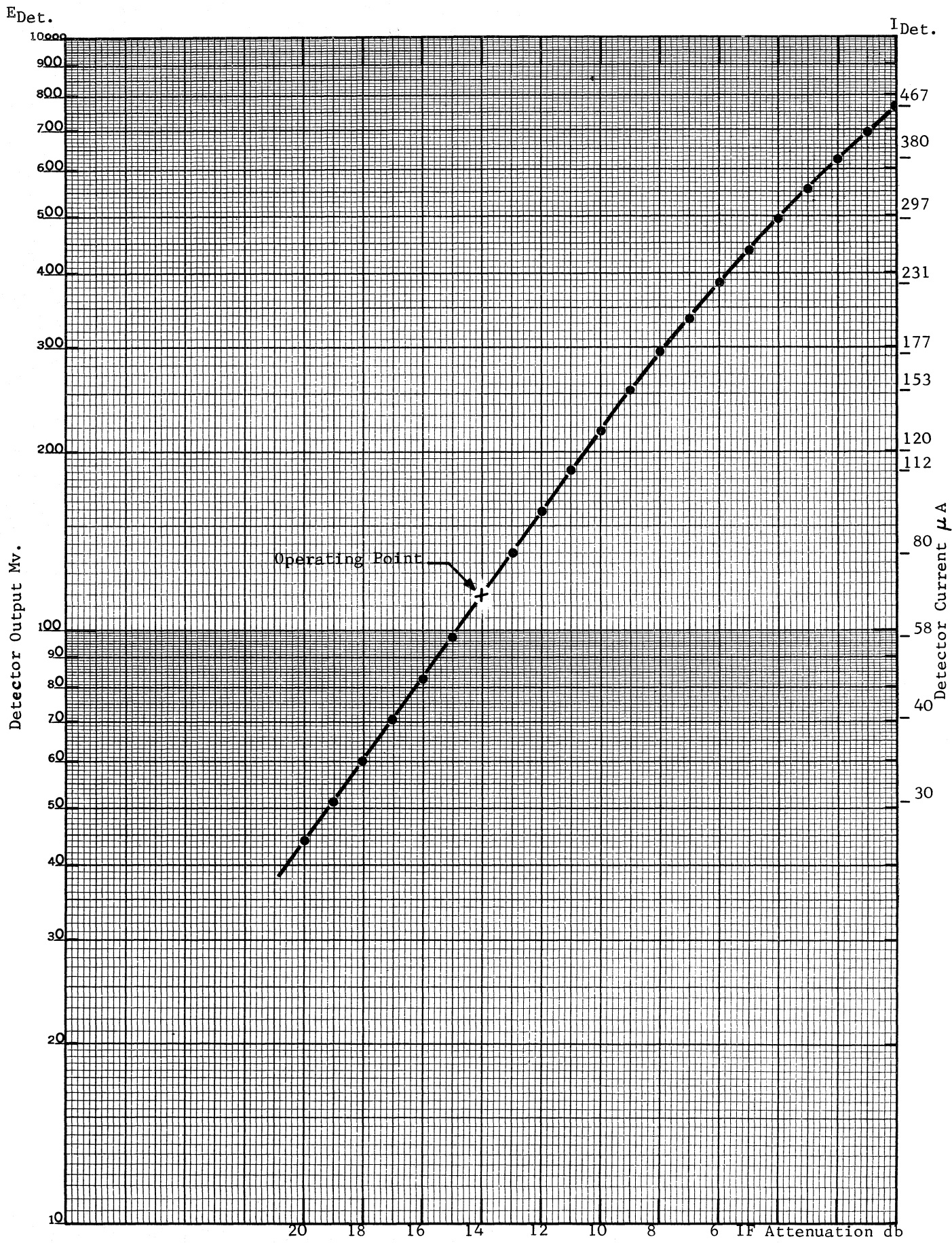

FIG. 6. BACK END DETECTOR CHARACTERISTIC

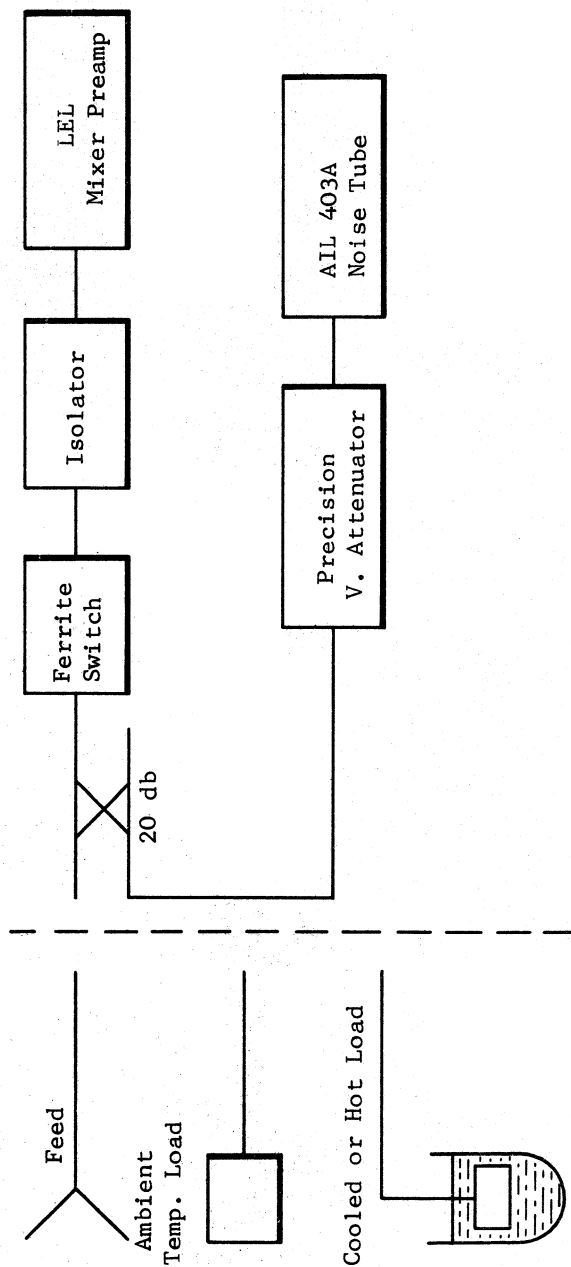
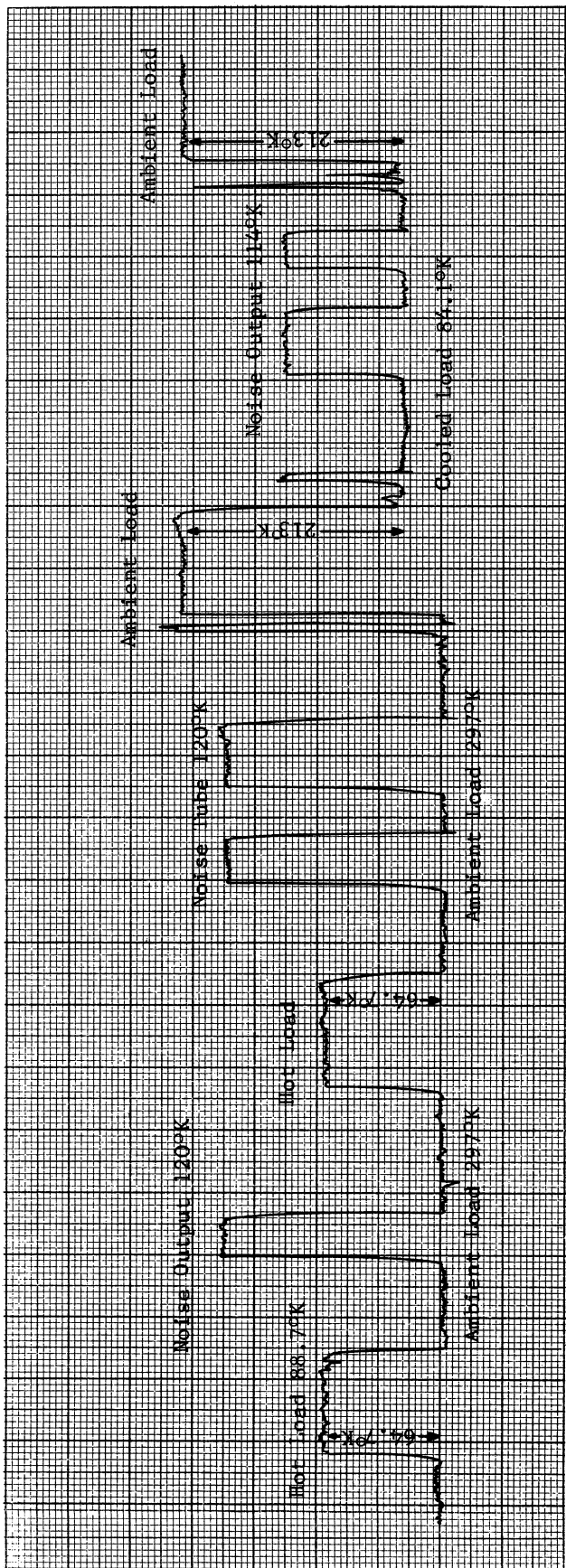

FIG. 7 CALIBRATION SETUP AND RECORD

The measured temperatures of liquid nitrogen and hot water (from tap) are 77°K and 364°K. It should be more accurate to simmer boiling water and use as hot load to maintain constant temperature. However, these measured temperatures have to be corrected for the load waveguide losses, for actual atmospheric pressure and load mismatch. The later two effects are small relative to the first<sup>1</sup> and the corrections applied here are only due to waveguide losses and are +7.1°K for the cooled load and -2.3°K for the hot load (364°K). In microwave radiometers, it is found convenient to switch between liquid nitrogen and ambient temperature loads to cover the temperature range of calibration signals. However, it is more accurate to check against both hot and cooled load above and below room temperature and take their average (117°).

To get an idea of the actual output from the noise tube, one can make the following computation: Assuming the noise tube output as 10,000°K and the measured insertion loss of the FXR attenuator 0.8 db (1.2 ratio), the output at the attenuator is  $\frac{10,000}{1.2} + \frac{(1-1)}{1.2} 297 = 8386$ °K. The average coupling of the directional coupler over the band is 19.5 db when measured at individual frequencies. In order to agree with the absolute calibration value 117°, the coupling should be 18.5 db. This may as well be so, since the noise spectrum is integrated over a wide band width.

##### 5. Noise Figure Evaluation

The LEL mixer preamp unit has a double channel noise figure of 12.0±0.5 db depending on the crystal pair used. Assuming a noise figure of 11.5 db gives an equivalent temperature of 3800°K. The total loss of the waveguide transmission line from the feed horn input to the input of the mixer preamp is 1.2db (1.32 ratio). Thus  $T_r$  referred to mixer input = 3800 (1.32) + 0.32 (297) = 5100°K.

However, the best noise figure of the radiometer, measured by Y factor method, for a particular set of crystals was  $5000^{\circ}\text{K}$ , giving

$$\Delta T_{\text{rms}} = \frac{1.57 (5300)^{\circ}\text{K}}{\sqrt{40 (10^6 \tau)}} = \frac{1.32}{\sqrt{\tau}}$$

For  $\tau = 10$  sec,  $\Delta T_{\text{rms}} = 0.416^{\circ}\text{K}$ . Assuming  $\Delta T_{\text{pp}} = 5\Delta T_{\text{rms}}$ ,  $\Delta T_{\text{pp}} = 2.08^{\circ}\text{K}$

Figure 8a shows one recorder run for this system with a calibration of  $5.8^{\circ}\text{K}$  (37mm) and  $\Delta T_{\text{pp}}$  (12mm)  $1.86^{\circ}\text{K}$ . Another run (Fig. 8b) with different crystal pair gives a calibration of  $11.6^{\circ}\text{K}$  and  $\Delta T_{\text{pp}}$  of  $1.93^{\circ}\text{K}$  as shown. The system noise measured and calculated from mixer noise figure and transmission line loss agrees as shown above. Assuming the best system noise  $5000^{\circ}\text{K}$ , the  $\Delta T_{\text{pp}}$  estimated also corresponds favorably with that from the laboratory test record. Since the performance is effected by gain instabilities as in Fig. 7, one should compare only the proper averaged sampling over short time intervals of digital output for accurate results.

## 6. Radiometer Performance

The noise temperature of the radiometer system was measured by the Y factor method with different local oscillator powers. The mixer crystal current is shown (Fig. 9) as an indicator of oscillator power. These measurements were made with four crystal pairs and show a range of crystal current values with fairly flat noise temperature. Figure 10 shows one of the total power runs with the cooled load connected. This indicates the gain stability over 3 hours (as nitrogen lasts only for 4 hours). OKI klystrons are used with regulated power supplies for all their electrodes and filaments. A technipower (0.005%) regulated d.c supply is used for the mixer preamp unit.

9.5 mm Receiver Switched between ambient loads (no gain modulator) 0.5 mm/min,  $\tau = 10$  Sec

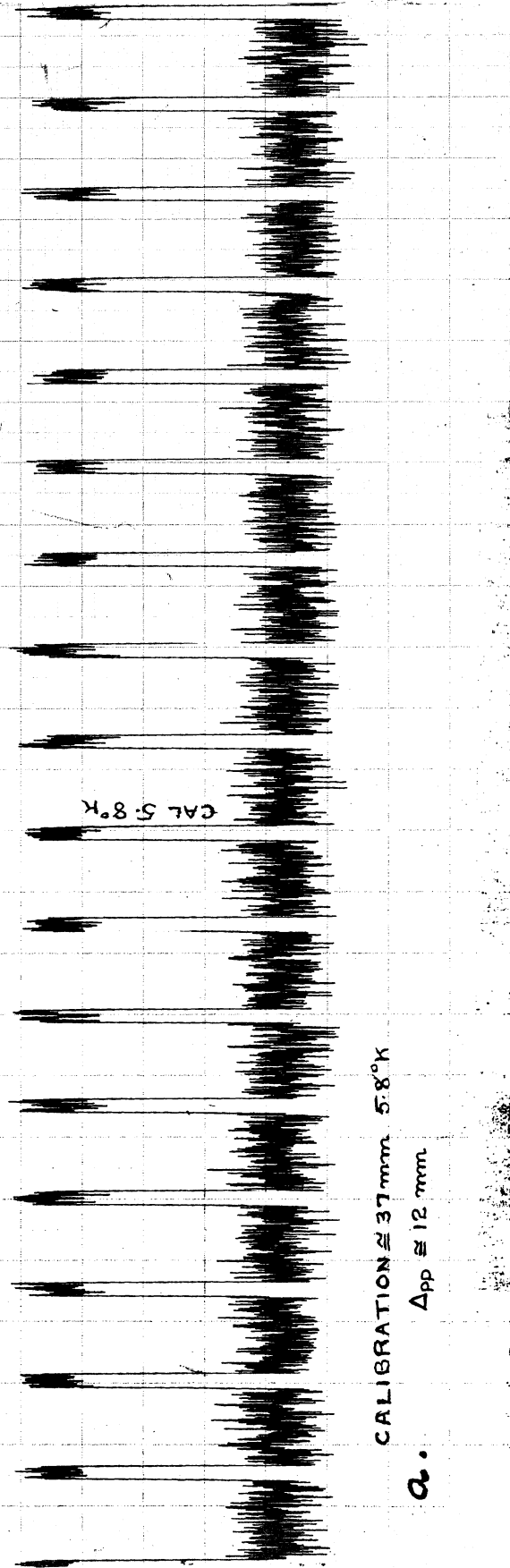

CALIBRATION  $\approx 37$  mm 5.8°K

App  $\approx 12$  mm

a.

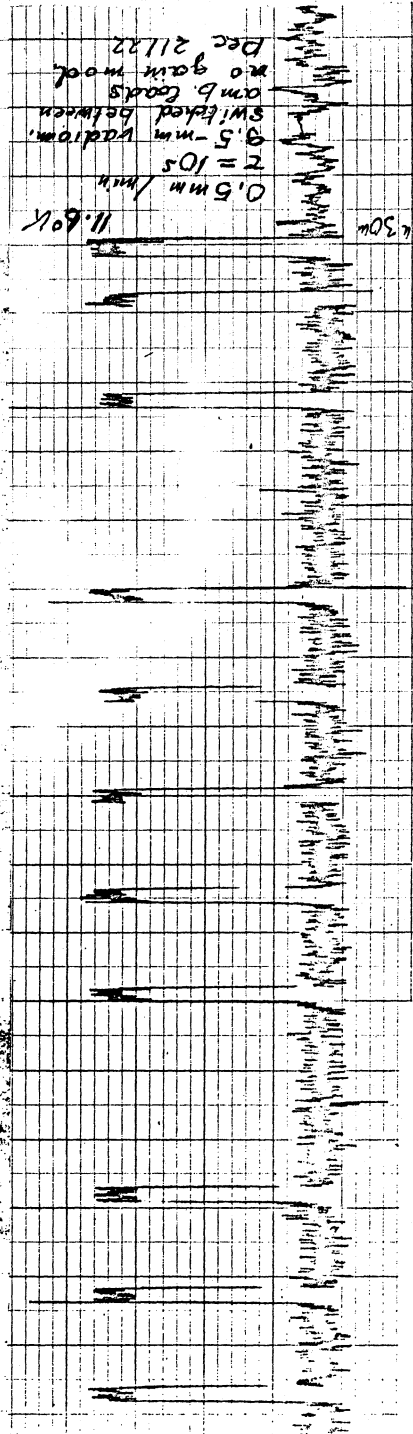

b. CAL  $\approx 30$  mm : 11.6°K

$\Delta p p \approx 5$  mm

FIG. 8. PERFORMANCE OF SWITCHED RADIOMETER



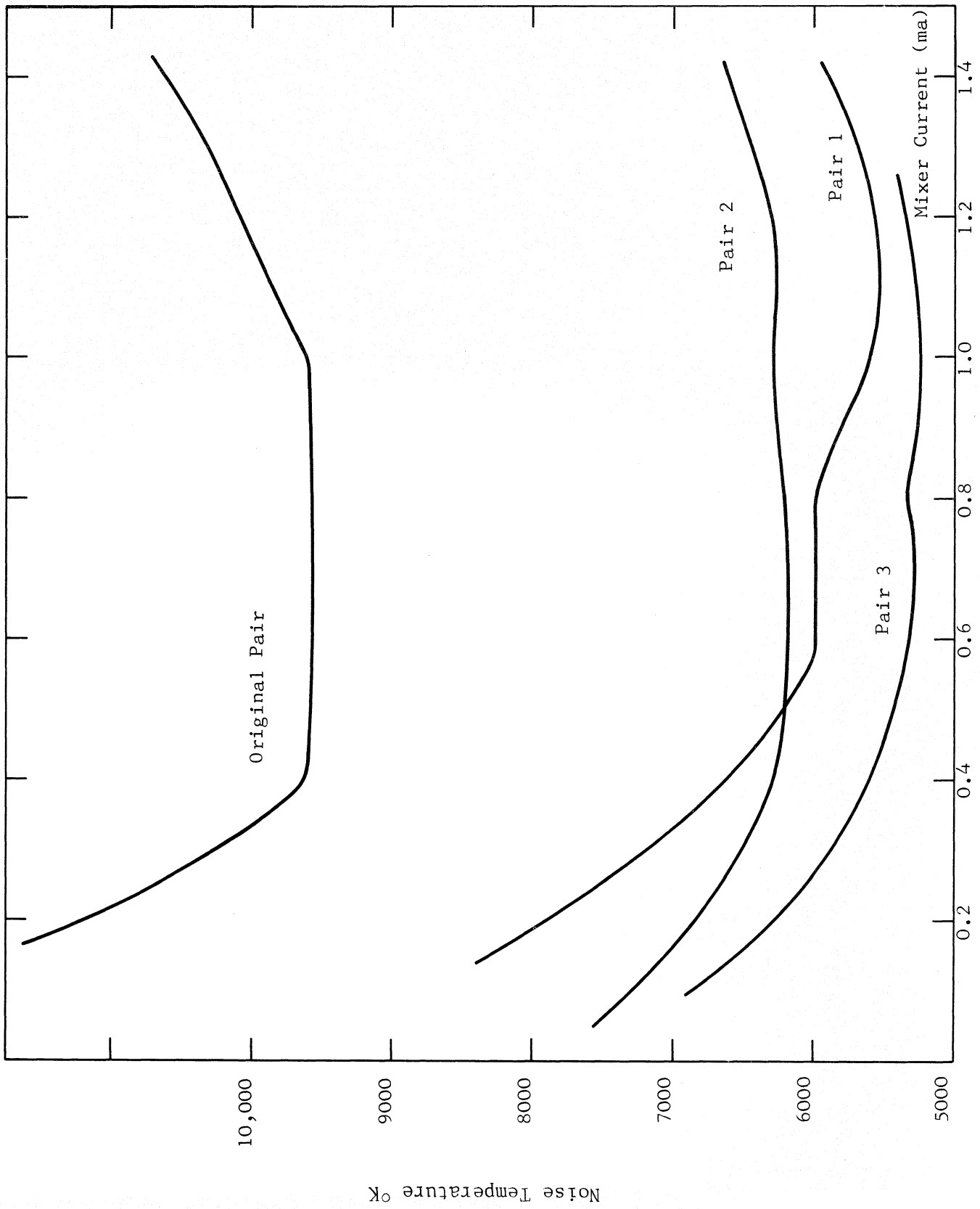

FIG. 9. NOISE TEMPERATURE VARIATION WITH L.O. POWER FOR VARIOUS CRYSTAL PAIRS

FIG. 10. PERFORMANCE OF TOTAL POWER RADIOMETER

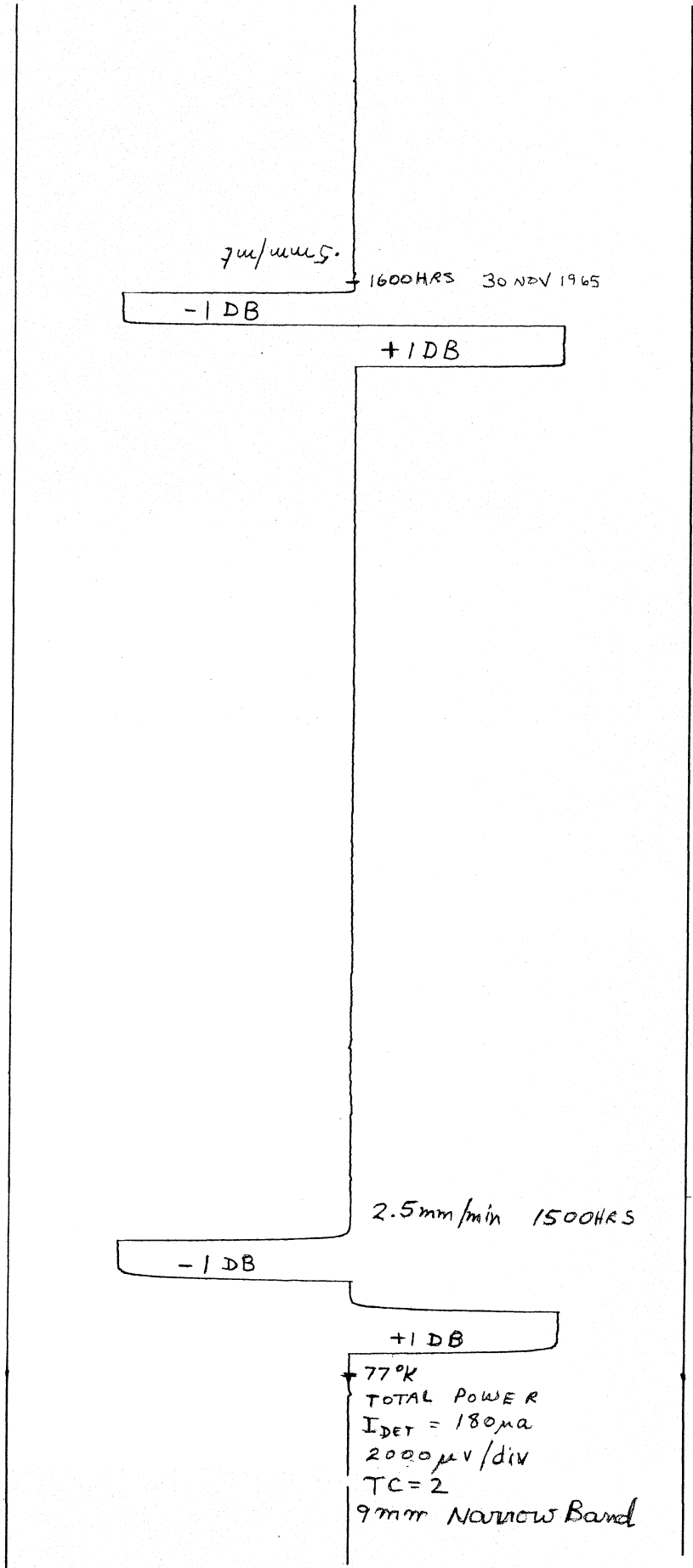

Figure 11 shows the radiometer output variation with variable backend temperature. In this experiment the front end temperature is held fairly constant and the room temperature is varied by heating and cooling the room over a 12<sup>o</sup>F range. Even though the telescope control room temperature is controlled over a smaller range, it is interesting to note the considerable output power changes till it finally settles to a steady value as shown, when the ambient temperature is held constant. Figure 12 shows the packaged 9.5 mm front end in one of the standardized temperature controlled boxes which fit the focusing and polarization mount of the 36-ft telescope. The box size is 11" x 11" in cross section and 34" in length. It needed quite a careful layout and design to assemble all the components in such light and small boxes.

We compute the minimum detectable flux density with 36-ft dish using the 9mm narrow band radiometer. Assuming an aperture efficiency of 55 % at this frequency and system noise temperature of  $T_s = 6300^{\circ}\text{K}$  one obtains

$$S_{\min} = \frac{2K\Delta T A(pp)}{A \sqrt{\tau}} = \frac{415}{\sqrt{\tau}}$$

(f.u)

Large integration times of the 100 second order are necessary to detect the weak sources at very high frequencies. This will set the minimum flux limit around 50 f.u with 36-ft.

$T_F$  : FRONT END TEMP  
 $T_A$  : AMBIENT  
 $T_B$  : BACK END TEMP

N 50°K CAL

TOTAL POWER  
 500  $\mu$ V/div  
 $T = 2$  SEC

$T_B = 71^\circ F$   
 $T_A = 16.4^\circ C$   
 $T_F = 75^\circ F$

$T_B = 75.5^\circ F$   
 $T_A = 25.6^\circ C$   
 $T_F = 76^\circ F$

$T_B = 70.5^\circ F$   
 $T_A = 23.2^\circ C$   
 $T_F = 76^\circ F$

$T_B = 65^\circ F$   
 $T_A = 15.0^\circ C$   
 $T_F = 75^\circ F$

$T_B = 86^\circ F$   
 $T_A = 27.4^\circ C$   
 $T_F = 77^\circ F$

N 50°K

$T = 2$  sec  
 500  $\mu$ V/div  
 2.5 mm/sec

$T_B = 69^\circ F$   
 $T_A = 16.3^\circ C$   
 $T_F = 74^\circ F$

FIG. 11. RADIONETER OUTPUT VARIATION WITH VARYING BACK END TEMPERATURE

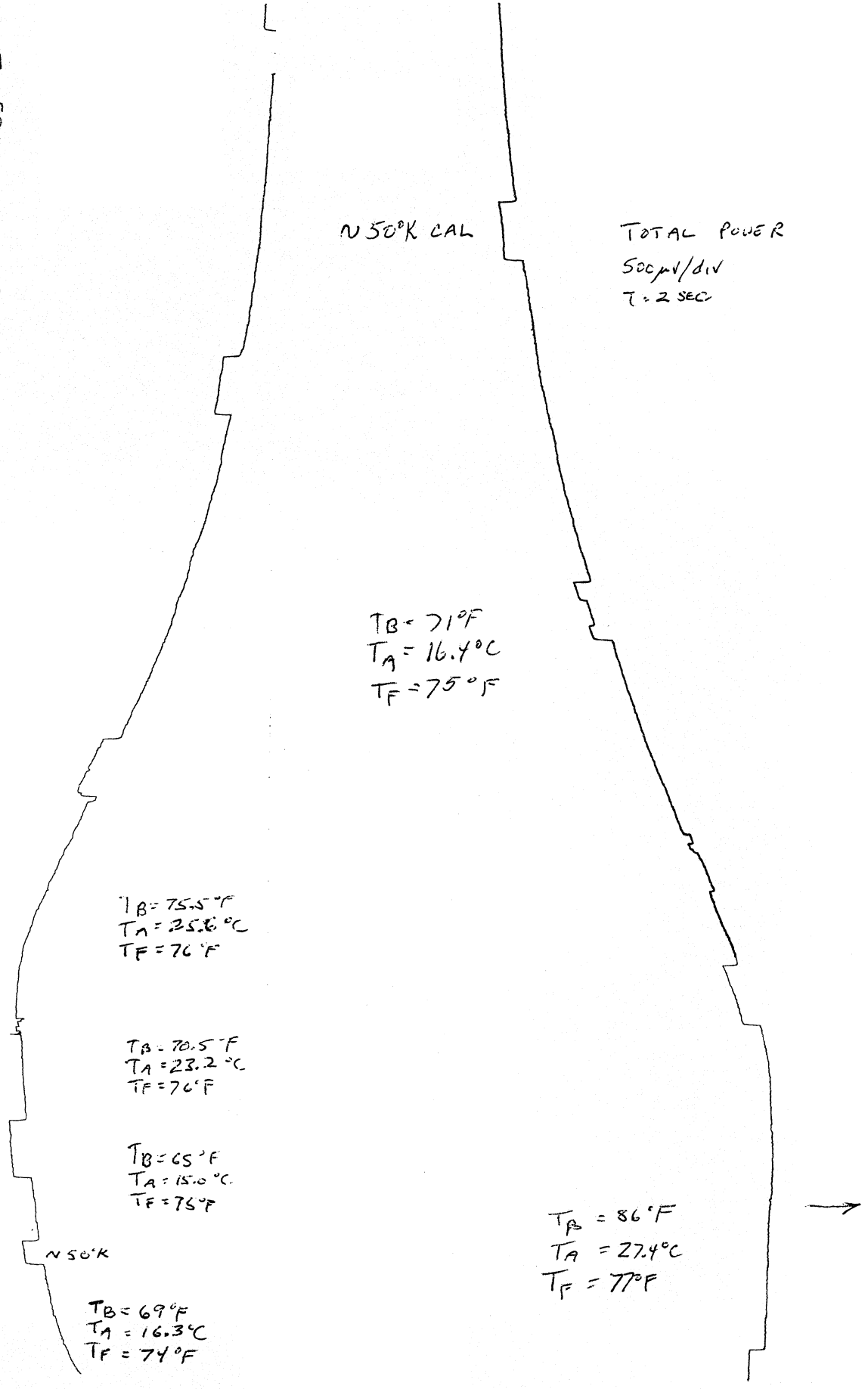

$T_B = 84^\circ F$   
 $T_A = 25.8^\circ C$   
 $T_F = 78^\circ F$

→  
20 IS HRS  
20 Jambit

$T_B = 66^\circ F$   
 $T_A = 15.0^\circ C$   
 $T_F = 73^\circ F$

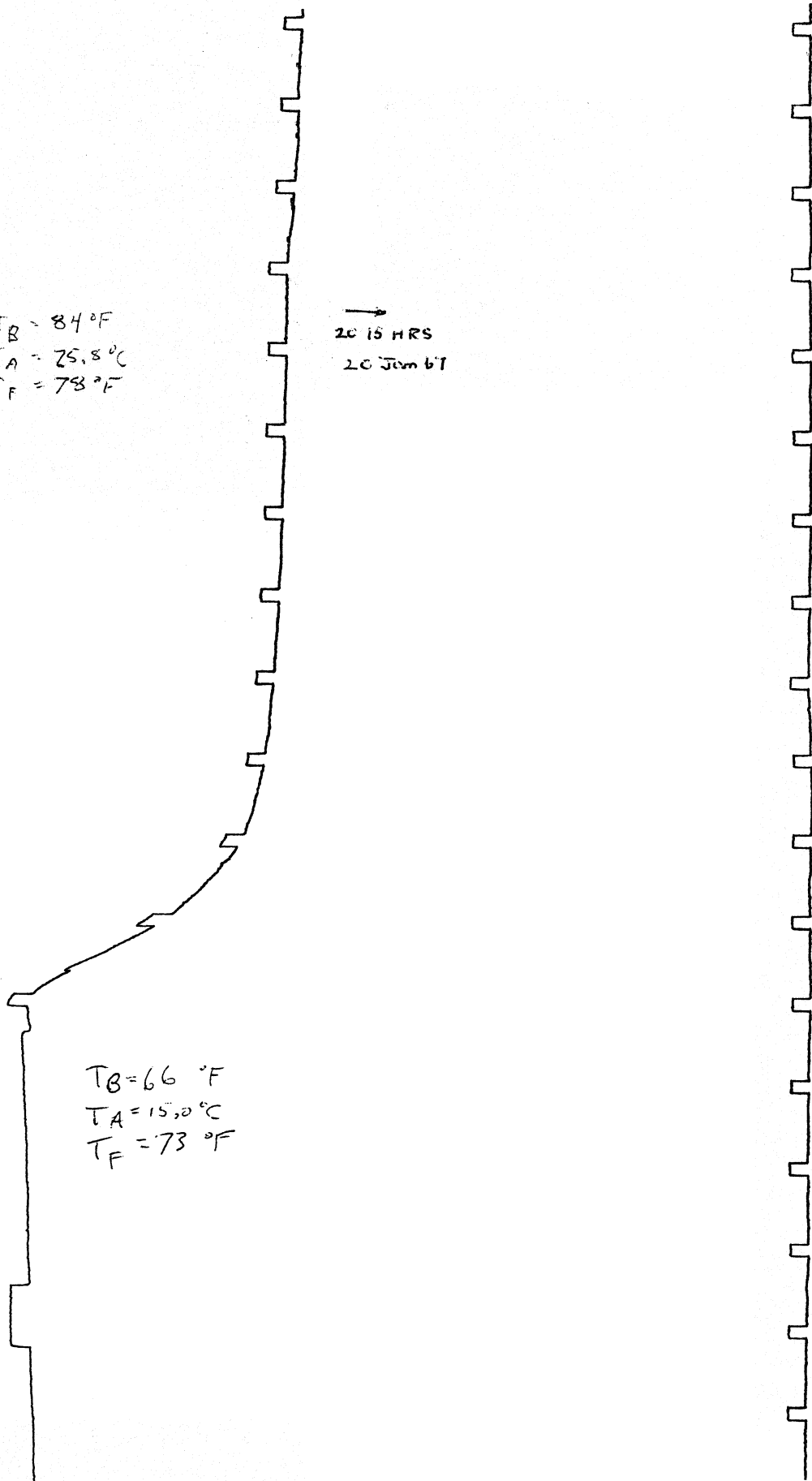

2144

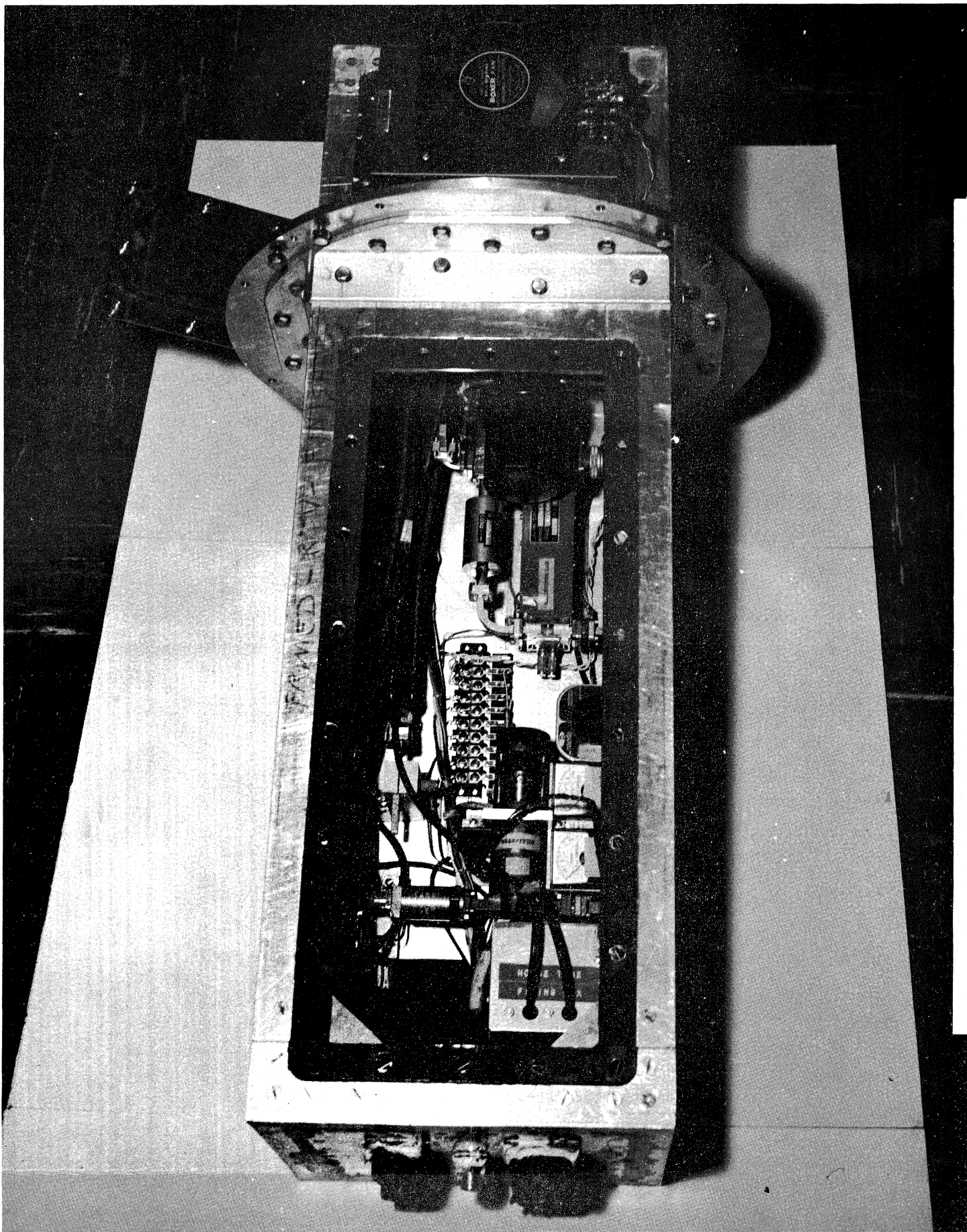

FIG. 12. PACKAGED FRONT END IN STANDARDIZED TEMPERATURE CONTROLLED BOX

## References

1. Rama C. Menon and Neil P. Albaugh, Advanced Technology Calibration Loads for the 2 cm, 9.5 mm and 3.5 mm Wavelength Range.  
Electronics Division Internal Report No. 54.
2. R. C. Menon, N. P. Albaugh and J. W. Dozier, "Cooled Loads as Calibration Noise Standards for the mm - Wavelength Range", Proc. IEEE, Oct. 1966, Vol. 54, No. 10, pp. 1501-1503.