

NATIONAL RADIO ASTRONOMY OBSERVATORY
Green Bank, West Virginia

Electronics Division Internal Report No. 59

PERFORMANCE CHARACTERISTICS
OF WJ-268 SERIES TWT'S

Rama C. Menon and Neil P. Albaugh

March 1967

INTRODUCTION

We have four WJ-268 series TWT's for use as IF amplifiers in 3.5 and 9.5 mm radiometers. We have encountered several types of unforeseen difficulties in the repeatability of their performance characteristics. The output power of the TWT is a product of noise temperature and gain, which in turn are functions of frequency. Experience has shown that the changes in output noise power are mainly due to gain changes rather than noise temperature changes. Thus the output power is found to vary with the initial warm-up time, the AC voltage fluctuations, the proximity of the tubes and with average or spot frequency measurements. The measurements on these tubes are discussed here under normal operating conditions considering various factors.

I. GENERAL CHARACTERISTICS

a. Factory Specifications

<u>Input Voltage:</u>	114 to 120 VAC ⁵	48 to 400 cps.
	105 - 125 VAC ¹	
	117 ±3 VAC ²	48 to 62 cps.
	115V ±10V ³	48 - 420 cps.
<u>Input Power:</u>	19 - 29 watts ¹	
	10 watts typical 8.w ²	
	10w max. ⁷	
<u>Ambient Temperature:</u>	20 to 30°C ⁵	
	-54°C to 85°C ^{2, 6}	
<u>Small Signal Gain:</u>	1.0 to 2.0G _c 25 db min. ^{2, 7}	
	0.95 - 2.1 G _c 22 db min. ⁷	
<u>Noise Figure:</u>	1.0 to 2.0 G _c	
	4.5 db typical ² 5.0 db max. ^{2, 3, 7}	
	0.95 - 2.1G _c 7.0 db max. ⁷	
<u>Saturated Output Power:</u>	-8dbm ⁷ min.	
	-5 dbm typical ²	
<u>Life:</u>	12 month shelf life: G _{ss} = 24 db min., NF = 7.0 db max. ⁸	
	3500 hrs. : G _{ss} = 24 db min., NF = 7.0 db max. ⁸	
<u>Magnetic Shielding:</u>	See Note 9	
<u>Input Impedance:</u>	See Note 5, pp. 3	

¹Final Data Sheet; WJ-268, serial No. 482.

²Technical Bulletin Vol. 5, No. 2, March, 1963, pp. 3.

³Quick Reference Catalog, March 1965.

⁴Appendix IV Qualification and Acceptance Test Specification and Test Procedure Manual for Watkins-Johnson Types WJ-268-3, WJ-269-3, WJ-271-3, and WJ-276-3, 7 May 1963, pp. 8.

⁵Test Specification Electron Tube Type WJ-268-3, pp. 6, Revision 2, 20 May 1963.

⁶Same as 4, pp. 11 and 12.

⁷Same as 5, pp. 4.

⁸Same as 5, pp. 5.

⁹Publication cited in Note 5, pp. 7, and Note 2, pp. 1.

b. Bandpass

Measurements of the bandpass of TWT # 667 are plotted in Fig. 1. The gain of the TWT was measured point by point every 100 MHz from 250 MHz to 2 GHz using the set up Fig. 2a. In the range 2 GHz to 4 GHz, a sweep measurement was made by the method shown in Fig. 2b. The gain curve in Fig. 1 is typical of the four WJ-268 TWT's at N. R. A. O. and has been found to be within the manufacturer's specifications in 1 to 2 GHz frequency range.

c. Saturation Power Output

The actual input and output powers of each tube are measured at three different frequencies within the band with the setup shown in Fig. 3a. This characteristic, plotted in Fig. 4, permits us to determine the dynamic range and the saturation output power of the amplifier. At lower input levels comparable to the tube noise, the linearity of the characteristic is influenced by the noise level of the TWT. The point at which maximum output is reached with increasing input power is known as the saturation output. For the radiometer system, it is of interest to see the broadband saturation power. This measurement is done with the setup similar to the one shown in Fig. 3b. A noise tube source is connected through the amplifier to make sure the TWT under test gets into saturation. The actual input power level with the test setup components is measured and varied to plot the saturation curve of tube 303 in the 1-2 GHz band. (Fig. 3b) Table I summarizes the measured values on all the tubes.

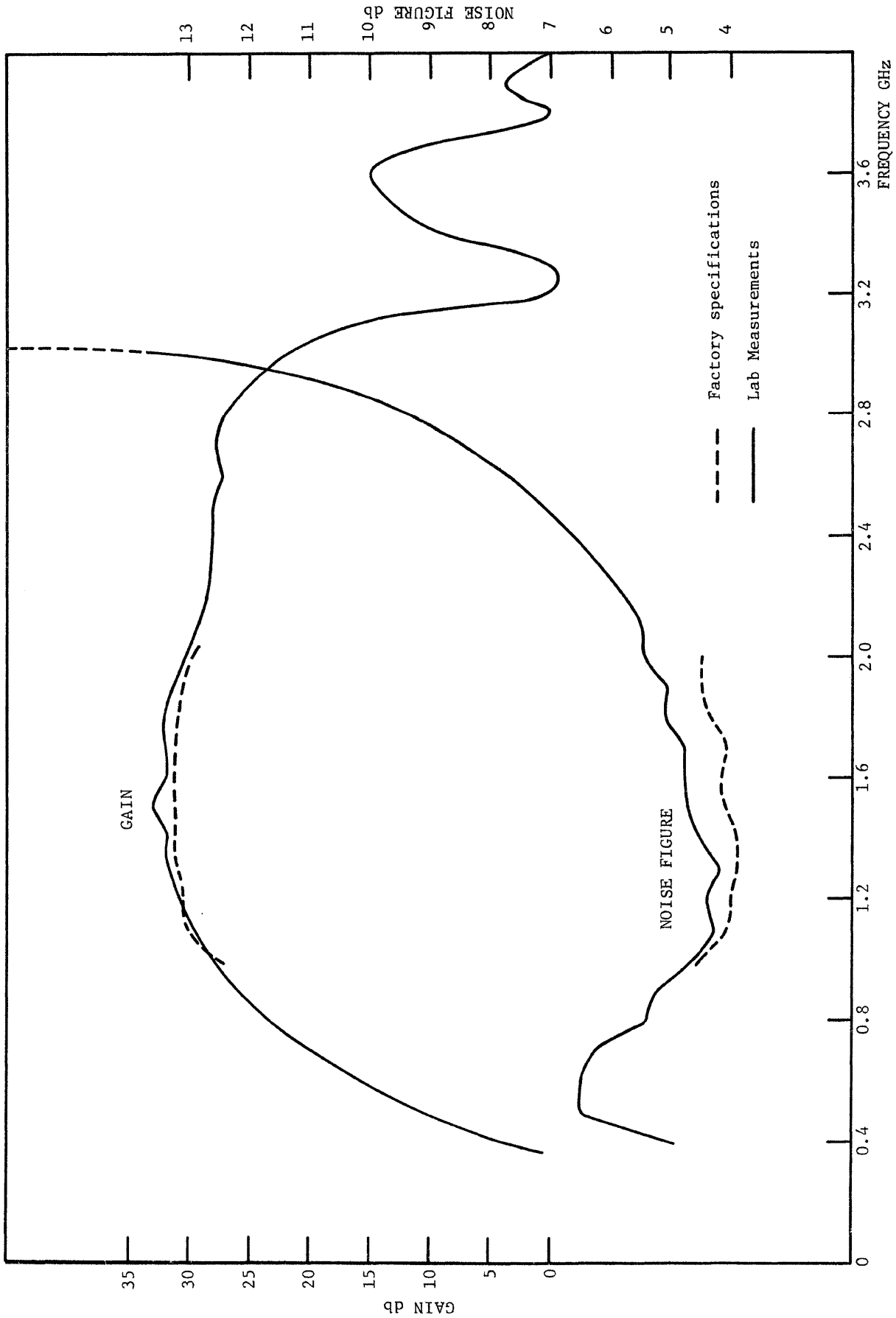

FIG. 1 GAIN AND NOISE FIGURE RESPONSE OF TWT 667

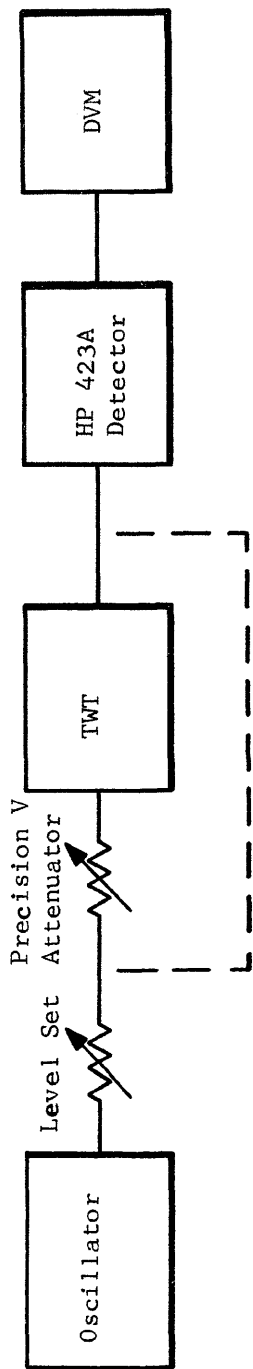

FIG. 2a SETUP FOR GAIN MEASUREMENT AT SPOT FREQUENCIES

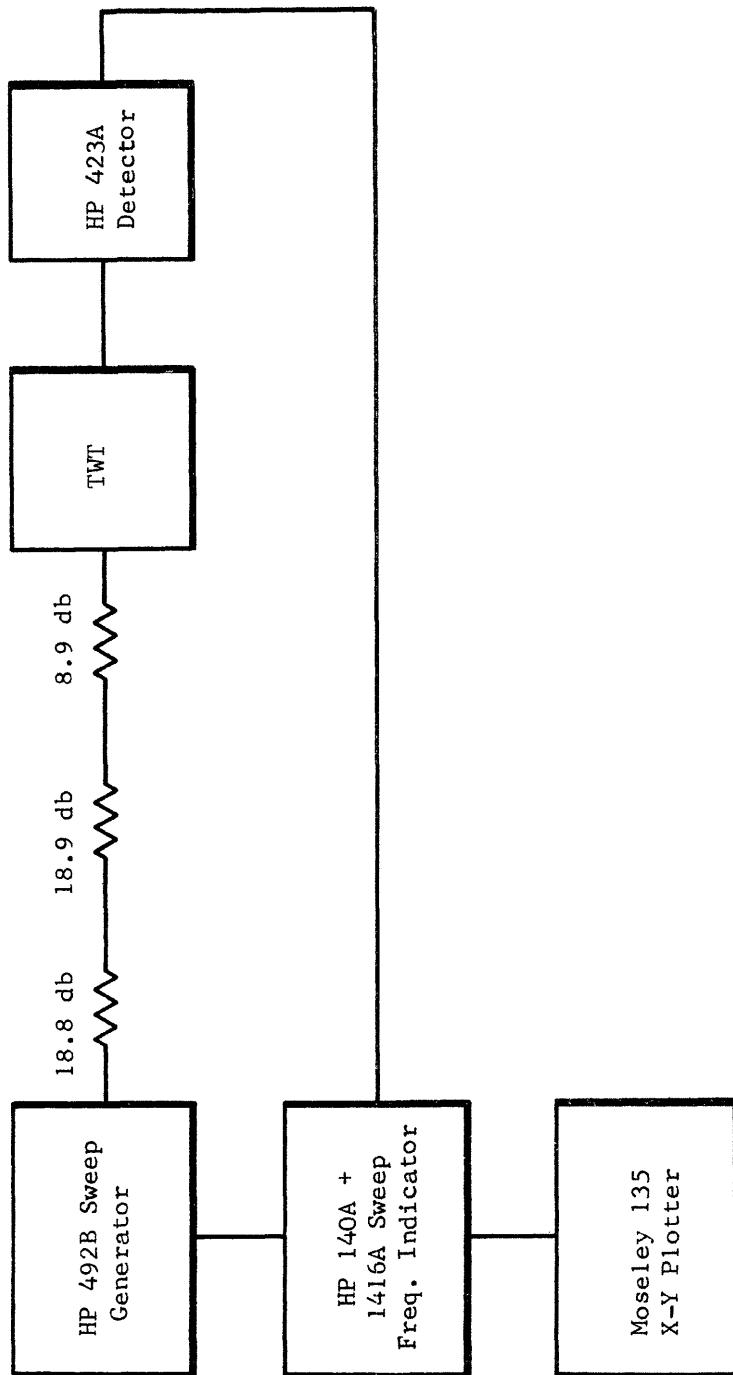

FIG. 2b SETUP FOR GAIN MEASUREMENT AT SWEEP FREQUENCIES

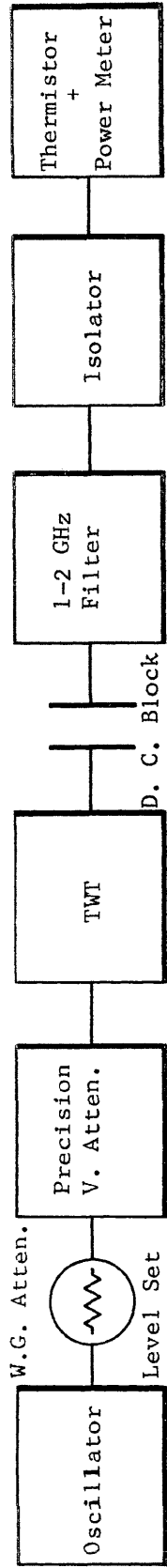

FIG. 3a SETUP TO MEASURE OUTPUT VS. INPUT POWER OF TWT

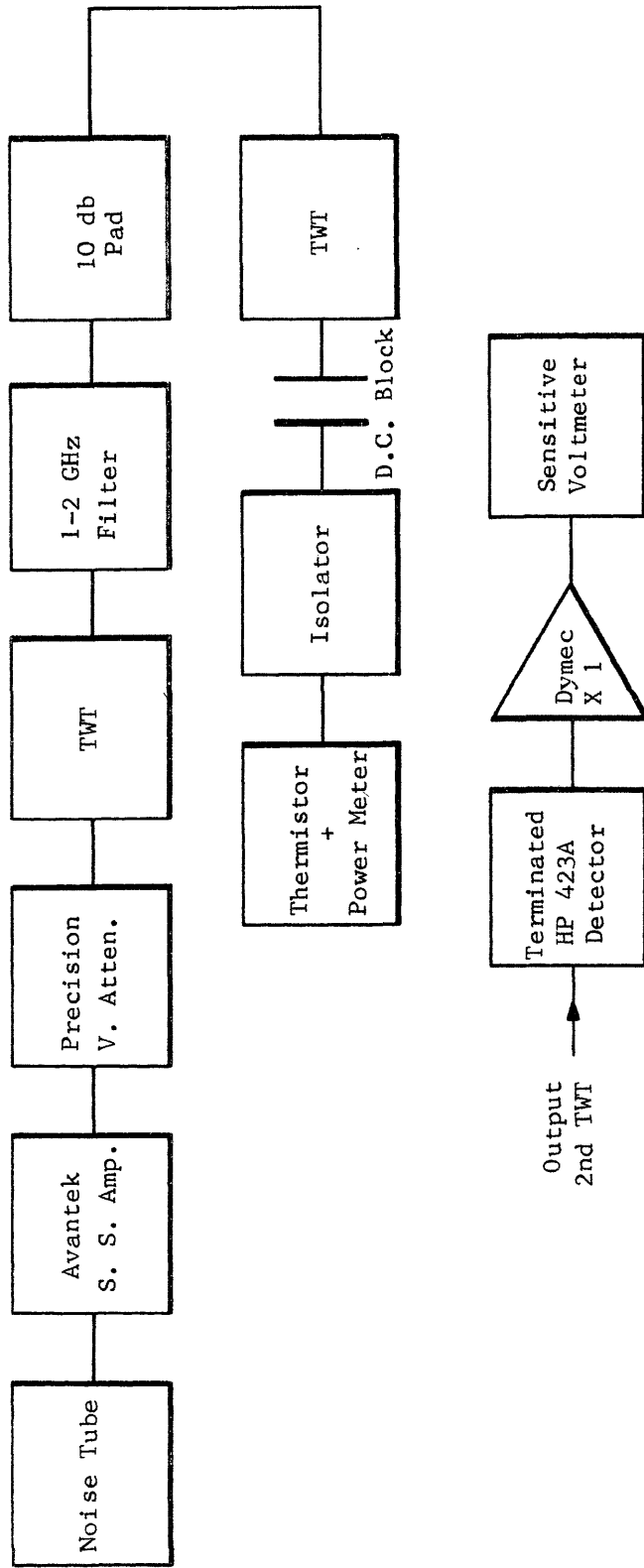

FIG. 3b SETUP TO MEASURE OVERALL I. F. CHARACTERISTICS

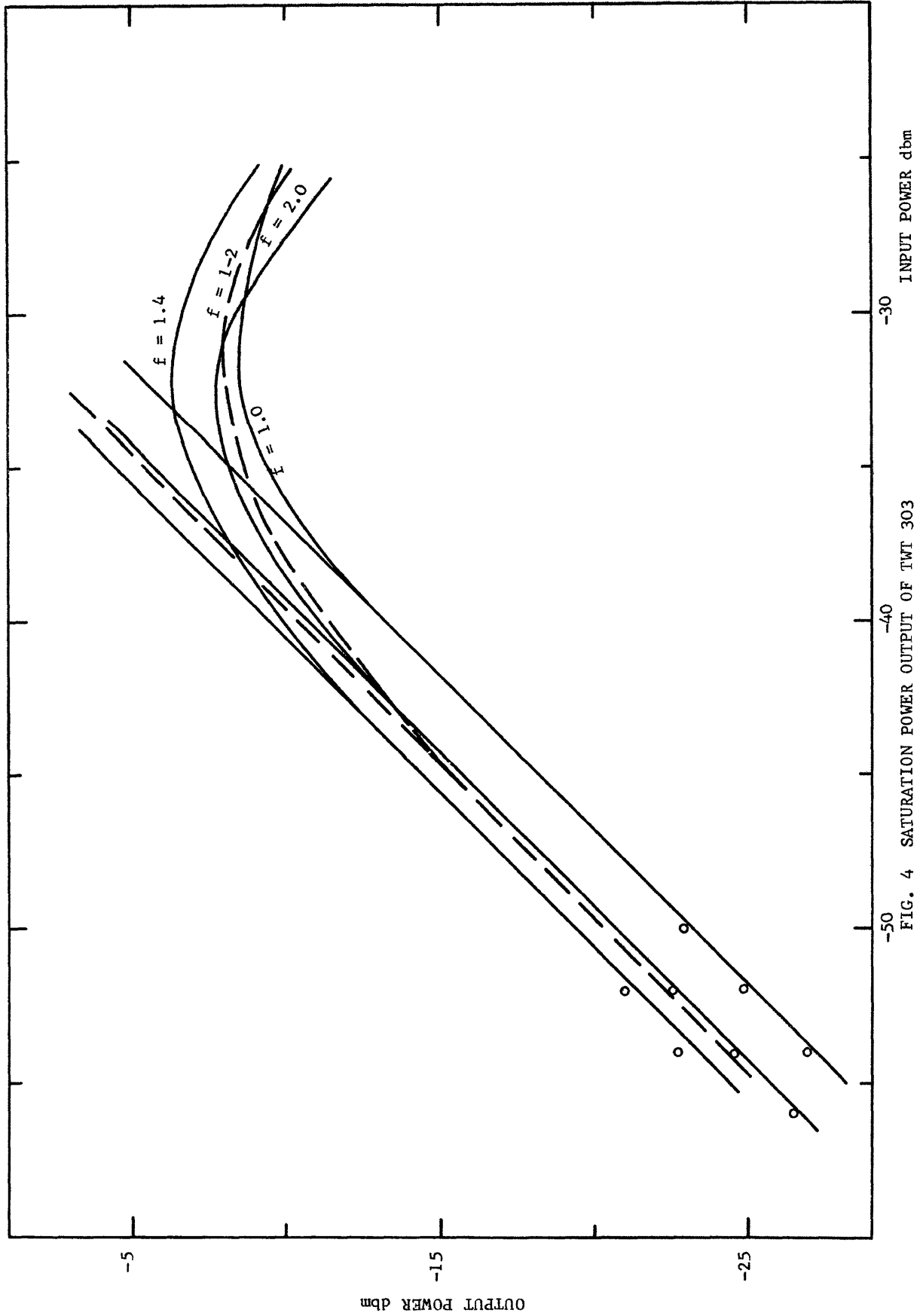

FIG. 4 SATURATION POWER OUTPUT OF TWT 303

Table 1. SATURATION POWER OUTPUT OF AMPLIFIERS

TWT	300		303		482		667		S.S.AMP
Output Power dbm									
Freq. GHz.	Meas.	Spec.	Meas.	Spec.	Meas.	Spec.	Meas.	Spec.	Meas.
1.0	-8.2	-7.3	-8.5	-6.8	-12.3	-10.4	-5.8	-3.6	-1.8
1.4	-5.0	-4.5	-6.3	-5.5	-10.9	-9.8	-4.8	-4.5	-0.6
2.0	-8.0	-6.6	-7.8	-5.8	-11.9	-9.7	-5.7	-4.2	-2.8
1.0-2.0	-6.4		-8		-12.7		-6		-2.0

One can see from the above table that every amplifier saturates at higher powers in the mid-band as compared to the band edges. The broad band saturation power is at lower power levels relative to the power at single mid-band frequency, as is expected.

II. GAIN STABILITY

a. Line Voltage

Serious problems with total power stability vs AC line voltage have become apparent. Fig. 5 shows the change in power output with change in AC line voltage on tube 300 and 667. For the tube 300 a calibration signal of 100°K excess noise was used at the input. Since TWT 667 is less sensitive to changes in line voltage, a calibration signal of 50°K was used. If we assume that the amplifier noise temperature does not depend on the variations in supply voltage, then

$$\frac{\Delta P_{out}}{P_{out}} \frac{1}{\Delta V_{AC}} = \frac{\Delta G}{G} \frac{1}{\Delta V_{AC}} .$$

The gain change amounts to 8% per volt for tube 300 and -1.1% per volt for tube 667. All the TWT's have self-contained power supplies. However, tubes 300 and 303 do not have regulated power supplies, whereas 667 has a regulated power supply. In case of 482, the manufacturer is not certain about the nature of the power supply. The measured better gain stability of 667 over 300 should then be the consequence of better regulation. This gain instability is a serious drawback for an IF amplifier of a total power radiometer.

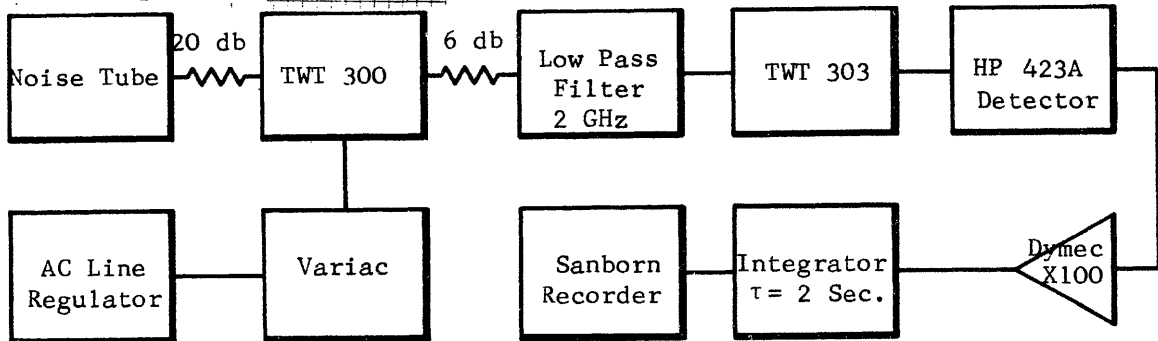
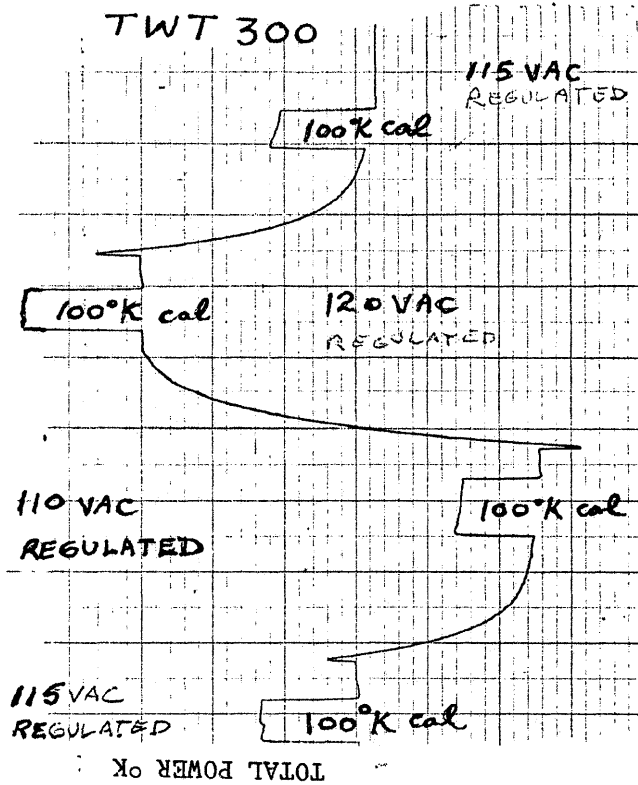
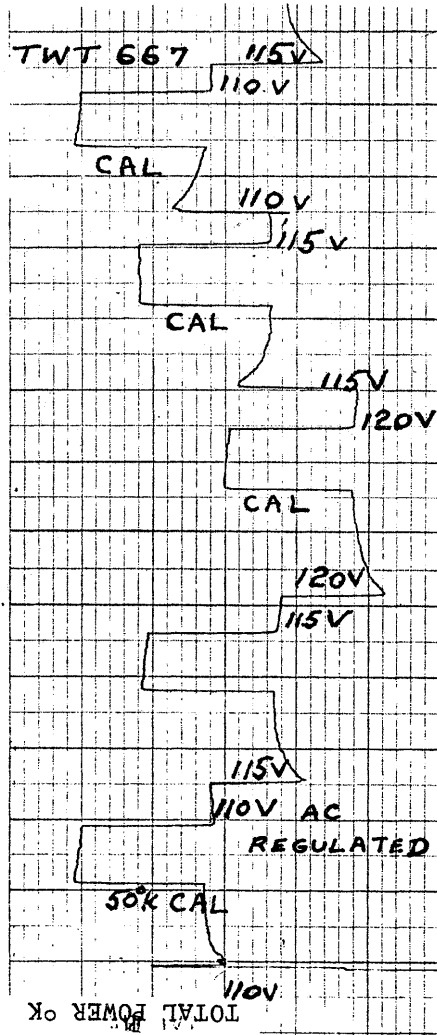

FIG. 5 TOTAL POWER OUTPUT VS. LINE VOLTAGE

b. Temperature

With the same assumption as in the above section, $\frac{\Delta P_{out}}{P_{out}} \frac{1}{\Delta T} = \frac{\Delta G}{G} \frac{1}{\Delta T}$.

By slowly varying the ambient temperature, it was found that the TWT's showed a change of 0.9% per °C in output noise power. The setup used being the same as shown in Fig. 5.

c. Input Impedance

The changes in total power output with changes in input VSWR are shown in Table II. The measuring setup is similar to the one shown in Fig. 6, except for a mismatch replacing the termination and with the TWT's at a large fixed distance apart. The TWT response is found to be insensitive to any change in input VSWR.

Table II. TOTAL POWER OUTPUT VS. INPUT VSWR

<u>VSWR</u>	<u>DVM READING, VOLTS</u>
1.0	0.896
1.3	0.887
1.6	0.888
2.0	0.892
∞	0.931

A trombone line was used to attempt to see total power output changes with input phase changes, but this was not conclusive due to a defective trombone line. Even if the TWT exhibited some phase sensitivity, it might not be detectable because of "smearing" of the effect by the wide TWT bandwidth.

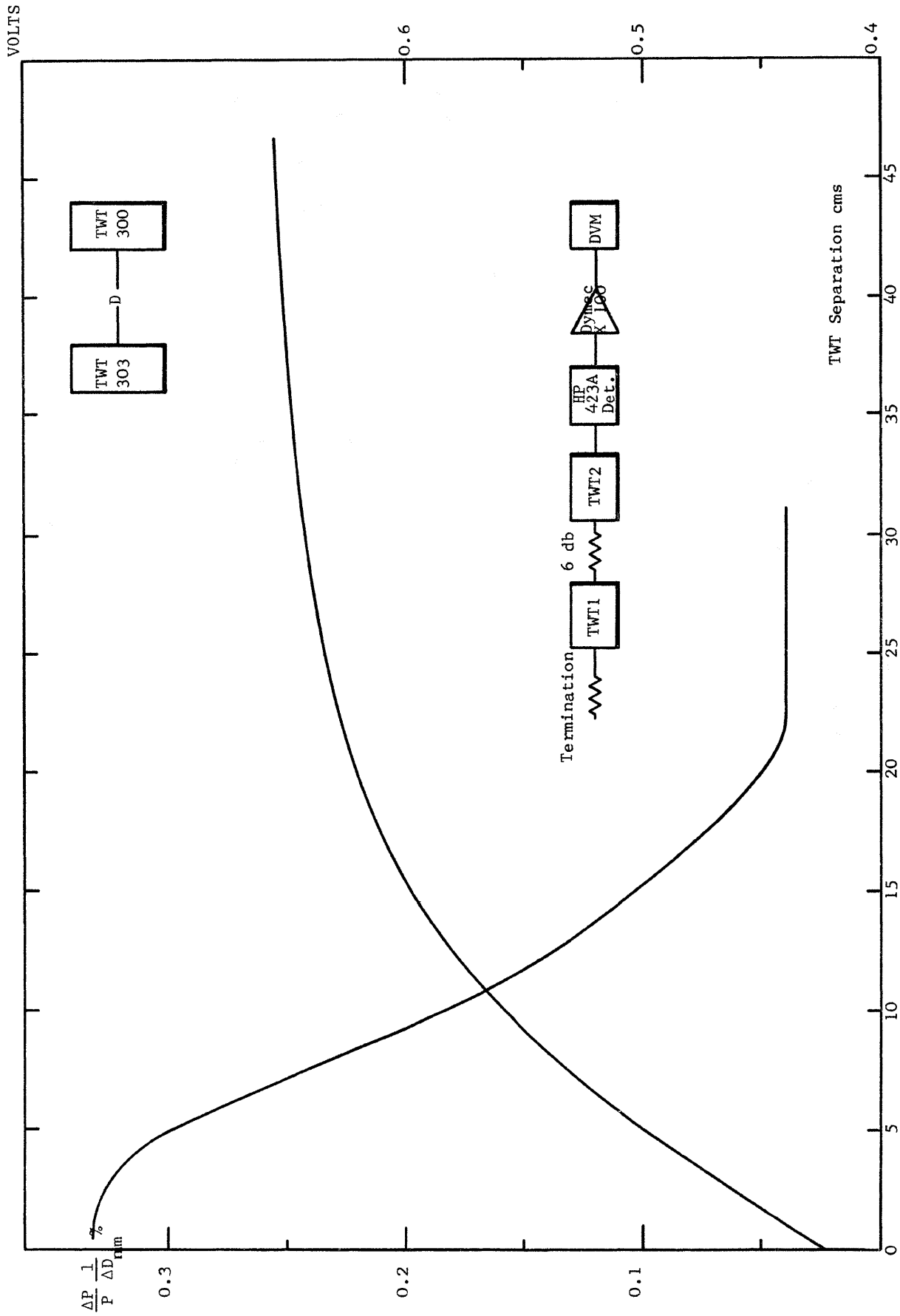

Fig. 6 NATURE OF OUTPUT POWER WITH TWT SEPARATION

d. Magnetic Isolation

Early in these series of tests, much difficulty was experienced with gain instability and drift. A well regulated line voltage reduced the problem, but measurements were not always repeatable. It was suspected that the external magnetic fields of the TWT's were interacting and causing gain changes. These suspicions were confirmed by the measurements in Fig. 6. The percentage power variation per mm separation, $\frac{\Delta P}{P} \frac{1}{\Delta D}$ is also plotted on Fig. 6. This variation is not significant, but is maximum for small separations. In the radiometer package for the NRAO 36-foot telescope, lack of space necessitates mounting the TWT's only 1 cm apart. Since the total power output is dependent upon physical separation, a rigid structure is needed to prevent spacing changes that would appear as changes in total power output.

e. Long-Term stability

Tubes 300 and 303 were bought 3 1/2 years ago and were used off and on for about 500 hours. Tubes 667 and 482 are 1 1/2 years old and were used only in the tube evaluation up to 100 hours. Tubes 300 and 303 do seem to have deteriorated in performance relative to 667 (fig. 6) and 482 in their sensitivity to AC line voltage. Since only four TWT's were tested, it is difficult to make a valid conclusion about their shelf life or the operating life.

III. EVALUATION OF TWT'S AS IF-AMPLIFIERS

a. System Noise Measurements

The noise figure of a unit is usually defined as

$$F = \frac{(S/N)_{\text{input}}}{(S/N)_{\text{output}}} = \frac{N_o}{KT_oBG} \quad (1)$$

Due to the variations in the gain with frequency, the effective bandwidth is given by

$$B = \frac{1}{G_{\max}} \int_0^{\infty} G(f) df \quad (2)$$

It is a common practice to express the relation (1) in terms of db, giving

$$N_o = 114 \text{ dbm} + F_{\text{(db)}} + \left(\frac{B}{\text{MHz}} \right) \text{(db)} + G_M \text{(db)} \quad (3)$$

If the measurements are made within a small bandwidth (2MHz) relative to the large band of interest, the average noise figure \bar{F} over the useful band is related to the narrow band or spot noise figure $F(f_R)$ by

$$\bar{F} = \frac{\sum_{R=1}^n F(f_R) G(f_R)}{\sum_{R=1}^n G(f_R)}$$

In the later part where we are concerned only with average noise figure, \bar{F} is replaced by F .

The broadband average noise figure is measured by twice power method using setup 7a and the narrow band or spot frequency measurement is done by "Y factor" method using the setup 7b. The average noise figure measurements with and without 1-2 GHz bandpass filter are shown in Table III. The presence of the filter does certainly improve the noise figure (from 0.8 to 1.40 db) by cutting off the high frequency end. The designation of spacing between the tubes corresponds to that in Fig. 6. One can see the slight improvement in noise figure as the tubes are brought closer, at the same time the gain also does decrease with the proximity of the tubes.

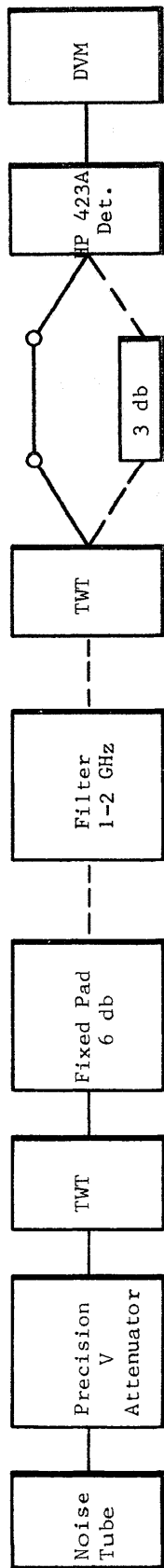

Fig. 7 a. AVERAGE NOISE FIGURE MEASUREMENT

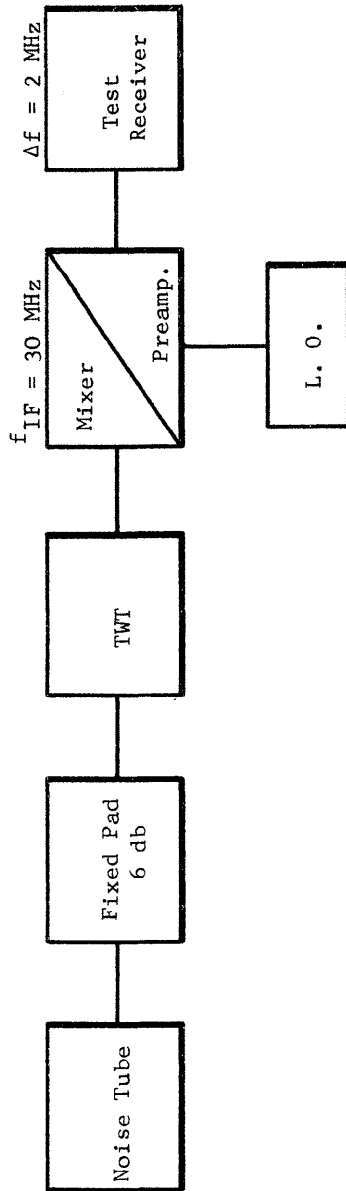

Fig. 7 b. SPOT NOISE FIGURE MEASUREMENT

Table III. MEASURED AVERAGE NOISE FIGURE

	<u>With Filter</u>		<u>Without Filter</u>	
	Noise Fig. (db)		Noise Fig. (db)	
TWT →	300 + 303,	303 + 300,	300 + 303,	303 + 300
Separation ↓				
Max (D>15")	5.34	4.99	6.13	6.29
Min (D=0)	5.25	4.85	6.03	6.03
TWT →	667 + 482,	482 + 667,	667 + 482,	482 + 667
Separation ↓	Noise Fig. (db)		Noise Fig. (db)	
Max (D>15")	6.29	5.18	7.70	6.38
Min (D=0)	5.86	4.99	6.68	5.95

The average noise figure is calculated from equation (4) using the spot frequency values of gain and noise figure from graphs similar to Fig. 1 in 1-2 GHz range. Such values are also computed from data sheets for comparison (Table IV) and found to agree favorably with our measurements.

Table IV. CALCULATED AVERAGE NOISE FIGURE

<u>TWT'S NO.</u>	<u>F_{db} in 1-2 GHz</u>	
	Calculated	Specified
300	5.0	4.60
303	4.8	4.80
482	4.6	4.35
667	4.8	4.25

We had considerable difficulty in obtaining repeatable gain and noise figure measurements due to a lack of good magnetic isolation in the TWT sheild, of a regulated power supply within the tube and due to long initial warmup time. Our experience showed the average noise figure reduces from about initial 7.0 db down to 5.0 db as the tubes are kept continuously on up to 12 hours.

Specifications suggest only a half hour warmup time, but during this time gain and noise figure were found to be unstable. Stable values however, are measured as the tubes were left continuously on for hours and days. Thus, we seem to run the risk of losing either shelf life or operating life. Using well regulated AC power supply (0.1%) and long initial warm-up time, the TWT's can be used in switched radiometer, but they will still limit the total power performance due to the gain instability presently found.

b. The optimum I.F. Pass Band

The sensitivity of a radiometer system is given as

$$\Delta T = T_s \sqrt{B} \quad (5)$$

It can be seen that the increase in system noise temperature can be compensated by increase in bandwidth. But we cannot keep on increasing the bandwidth to improve system noise because increased bandwidth is prone to gather interference. Thus there is an optimum $T_s \sqrt{B}$ for any system. But in this case the ratio $T_s \sqrt{B}$ is found to be rather insensitive in various frequency intervals, as shown in Table V.

Table V. $T|\sqrt{B}$ VALUES FOR VARIOUS FREQUENCY INTERVALS

<u>f Range GHz</u>	$\frac{n}{\Sigma G}$ <u>1</u>	<u>B GHz</u>	<u>F db</u>	<u>T°K</u>	<u>$T \sqrt{B}$</u>	<u>Tube 300</u>
0.4 to 2.0	6753	.85	5.0	630	2.16×10^{-2}	
0.4 to 2.6	8625	1.10	5.3	700	2.12×10^{-2}	
0.4 to 3.0	9238	1.16	5.7	790	2.31×10^{-2}	
1.0 to 2.0	6574	.83	5.0	630	2.19×10^{-2}	
1.0 to 2.6	8446	1.06	5.3	700	2.15×10^{-2}	
1.0 to 3.0	9059	1.14	5.6	770	2.28×10^{-2}	
						<u>Tube 303</u>
0.4 to 2.0	6986	.88	4.8	590	1.99×10^{-2}	
0.4 to 2.6	7357	.93	5.15	630	2.08×10^{-2}	
0.4 to 3.0	7858	.99	5.50	745	2.36×10^{-2}	
1.0 to 2.0	6795	.86	4.80	590	2.01×10^{-2}	
1.0 to 2.6	8256	1.04	5.12	630	1.95×10^{-2}	
1.0 to 3.0	8935	1.13	5.40	740	2.11×10^{-2}	
						<u>Tube 482</u>
0.4 to 2.0	8154	.82	4.6	550	1.92×10^{-2}	
0.4 to 2.6	9684	.97	5.1	660	2.12×10^{-2}	
0.4 to 3.0	10014	1.00	5.6	770	2.44×10^{-2}	
1.0 to 2.0	8010	.80	4.6	550	1.94×10^{-2}	
1.0 to 2.6	9540	.95	5.1	650	2.10×10^{-2}	
1.0 to 3.0	9870	.99	5.6	770	2.45×10^{-2}	
						<u>Tube 667</u>
0.4 to 2.0	8080	.81	4.8	600	2.11×10^{-2}	
0.4 to 2.6	9944	.99	5.3	650	2.06×10^{-2}	
0.4 to 3.0	10623	1.07	6.3	950	2.91×10^{-2}	
1.0 to 2.0	7813	.78	4.8	590	2.11×10^{-2}	
1.0 to 2.6	9677	.97	5.3	700	2.25×10^{-2}	
1.0 to 3.0	10356	1.04	6.35	960	2.98×10^{-2}	

The various parameters in the table are calculated from the gain and spot noise figure response curves similar to Fig. 1. Specifically, B is computed from equation (2) assuming G, and F is calculated from (4). One can see that there are several frequency intervals that give the same optimum value to $T|\sqrt{B}$. We can see some interesting features from Fig. 1. It can be seen that even though the noise figure increases gradually at the low frequency end, since the gain also falls off rapidly there, the average system noise temperature is not affected. This has also been confirmed by measuring the average noise figure over the entire band pass with and without a 1 GHz high pass filter. The gain is found to be

appreciable up to 3.0 GHz; however, the spot noise figures increase rapidly beyond 2.6 GHz, resulting in larger average noise figure. This feature also is confirmed by noise figure measurements with and without a 1-2 GHz filter. Thus the noise figure is found to be higher without this filter due to the nature of high frequency response of the TWT.

The advantages of using a high intermediate frequency with regard to crystal noise ratio (including the local oscillator noise contribution) are well known¹. Also the mm wave klystrons have higher noise outputs that extend over larger bandwidths. With the available better conversion loss diodes the local oscillator noise contribution to overall crystal noise ratio becomes pronounced. Thus, the minimum intermediate frequency, at which the local oscillator noise becomes a negligible part of crystal noise is recommended around 1 GHz depending on the bandwidth². In our 9.5 mm and 3.5 mm broadband radiometer system, the upper limit of the I.F. frequency is set at 2 GHz due to the response of front end ferrite switches and of the mixers. Thus, the frequency range of interest to us is 1-2 GHz, giving a useful bandwidth of 0.82 GHz and $T|\sqrt{B}$ about 2.12×10^{-2} .

c. Characteristics of the I. F. Stage

The output vs. input power of the overall I. F. stage is measured from the setup shown in 3b. The output power from the noise tube alone is not enough to drive the second tube in I. F. stage into saturation as shown in Fig. 8a Hence, the noise power is increased by an amplifier to obtain the dynamic characteristic as shown in Fig. 8b For absolute power measurements at these low levels it is found necessary and important to null the power meter carefully and to periodically check the zero to assure consistent values. As the d.c. voltage from the TWT is found to leak into the power meter, d. c. block is used to measure only the a.c. voltage.

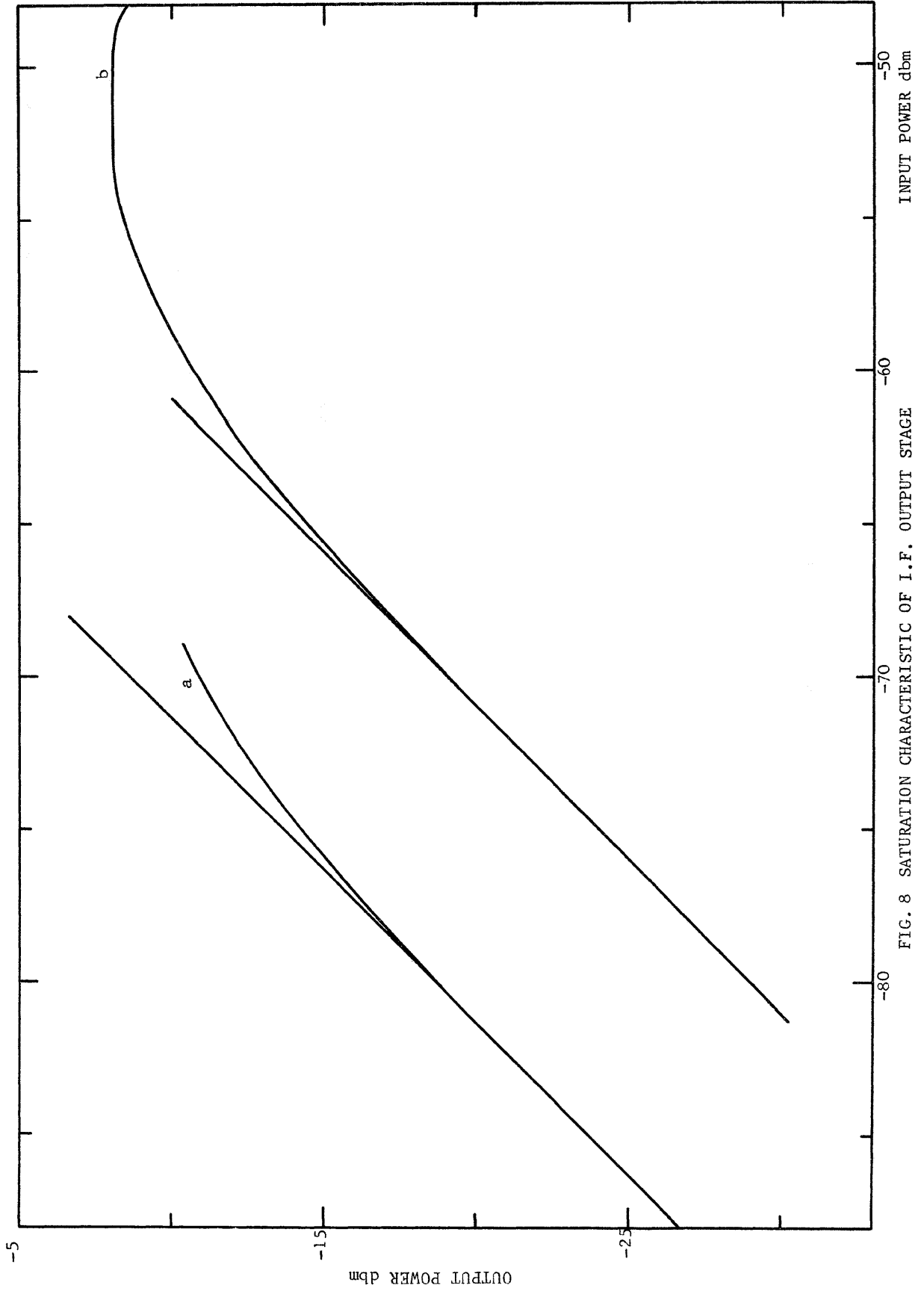

FIG. 8 SATURATION CHARACTERISTIC OF I.F. OUTPUT STAGE

Since the thermistor is found to be sensitive to TWT output impedance, an isolator is provided for better impedance match. Also, care should be taken to null the power meter at the same impedance level with the measuring setup off.

Even though the second TWT in setup 3b will not be overloaded at small signal levels, the 10 db pad is inserted between the two stages to reduce the noise level of tube 1 at the lower signal levels. The noise level of various combinations of two TWT's in series (with input terminated) is measured and found to be in agreement with the calculated noise power output. It has been found, as shown in Table I, that the broadband saturation level is not too different from the average saturation level measured from several individual frequencies within the band.

With the setup being the same as in Fig. 3b, the second TWT output is connected directly through a HP 423A detector with matched load to a sensitive voltmeter. The Dymec amplifier is used to improve the sensitivity at the low signal end. Fig. 9a shows the entire I.F. response whereas Fig. 9b shows the output vs input of the detector alone. The detector output is linear up to 50 mv as given in the specification and the detector response is close to square law. In the curve of Fig. 9a, the nonlinearity is due to the saturation feature of the second TWT. Thus, the sensitivity of the HP 423A detector is found to be 0.22 mv/ μ w, close to its specification. From this, one can find the dynamic range of operation of the overall I.F. stage.

IV. Conclusions

From the detailed evaluation of all the four TWT's we are now in a position to summarize their relative merits.

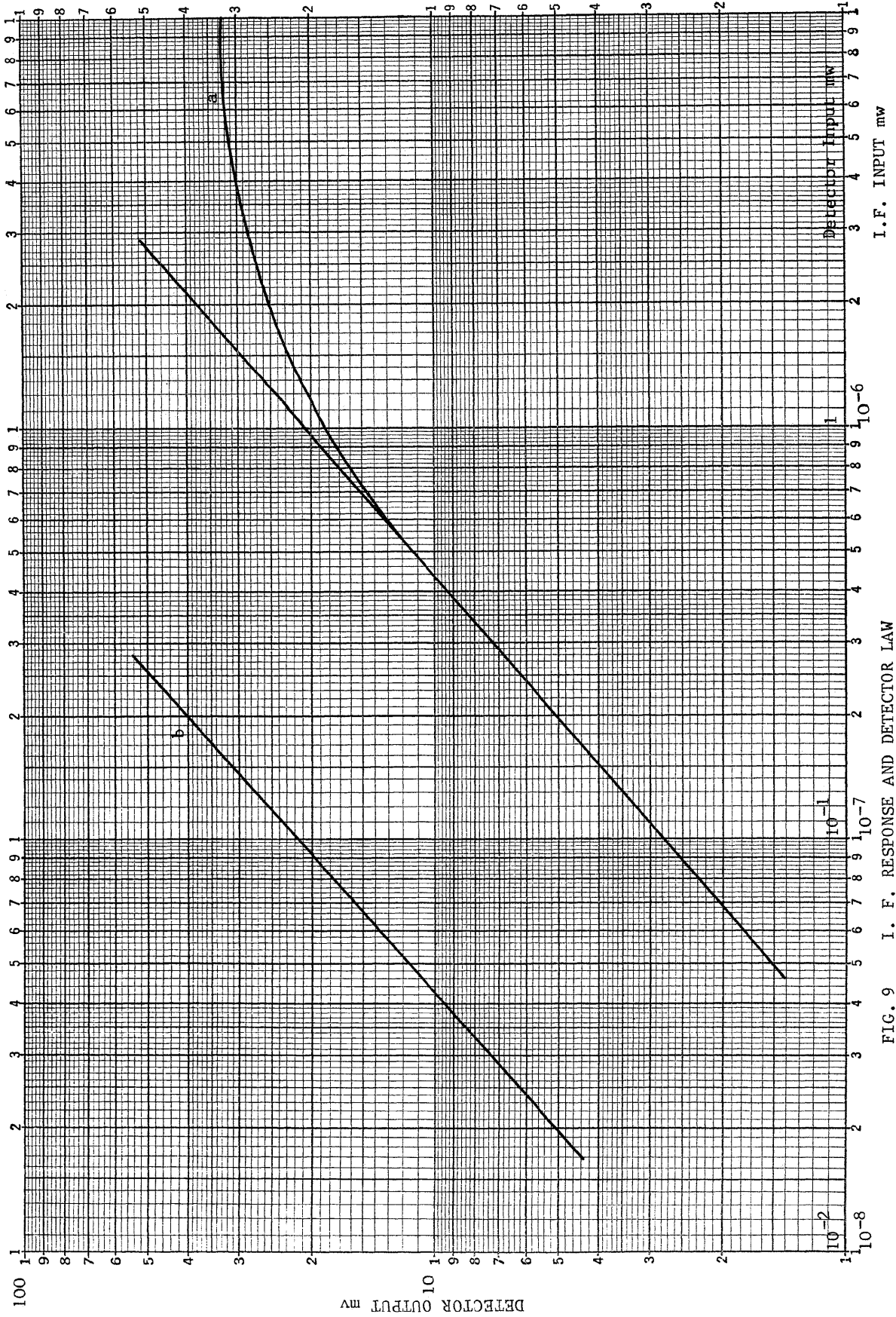

FIG. 9 I. F. RESPONSE AND DETECTOR LAW

Advantages

Commercially available
Low sensitivity to input VSWR.

Disadvantages

Heavy weight.
Limited shelf life and usable lifetime.
Characteristics depend on initial warmup time.
Strong magnetic field may influence ferrite components.
High power dissipation.
Variation in performance with time.
Poor gain stability.

Some of these features were known and anticipated and the others were found unexpectedly as mentioned earlier. Similarly, some facts about solid state units like light weight, small size, low power dissipation and indefinite lifetime are known. However, until recently, the units have been only custom built. From the preliminary measurements made on Avantek solid state amplifiers, it is found to be promising. The noise figure of the amplifier is about 5 db, as specified, with and without the 1-2 GHz filter. It is more sensitive to input VSWR than the TWT. It has lower gain but higher saturation power than TWT. The gain stability is quite good in its small output power variations, 0.1 dbm/volt with $\pm 2V$ variations over and under the operating D. C. voltage. The detailed performance characteristics of Avantek Am-1000 will be reported separately. We can now state that from the viewpoint of short warm up, indefinite lifetime, good gain stability (with comparable bandwidth and noise figure to TWT), light-weight and small size, it is advantageous to use a solid-state amplifier at least as the first stage (of the two stages) of each of our broad band radiometers at 9.5 and 3.5 mm.

References

1. "Microwave Mixer Performance at Higher Intermediate Frequencies"
1959 IRE Nat'l. Conv. Rec., pt. 3 pp. 160-176.
2. "MM Wave Semiconductor Diode Detectors, Mixers and Frequency
Multipliers" Proc. IEEE, April 1966, Vol. 54, No. 4, pp

National Radio Astronomy Observatory
Green Bank, West Virginia

Electronics Division Internal Report No. 59 A

Performance Characteristics of
the Avantek AM-1000 Transistor Amplifier

Neil P. Albaugh
Rama C. Menon
H. Donald Logan

April, 1967

INTRODUCTION

Recently, octave bandwidth transistor amplifiers with low noise figures have become available. This report is an evaluation of an Avantek AM-1000 as a millimeter-wave radiometer IF amplifier.

I. General Characteristics

a. Factory Specifications

The manufacturers specifications are listed below in Table 1.

TABLE 1

Frequency	:	1.0-2.0 GHz
Gain	:	25 db nominal
N.F.	:	6.0 db max.
Input VSWR	:	2.0 max.
Output VSWR	:	2.5 max.
-1 db Gain Compression	:	-6 dbm min.

b. Bandpass

The frequency response is shown in figure 1. Gain was measured point-by-point every 100 MHz from 500 MHz to 2.0 GHz. Sweep frequency methods were used from 2.0 GHz to 4.0 GHz. A block diagram of the test measurement set-up is shown in figure 2.

The discontinuity of the gain curve at 2.0 GHz is apparently due to the amplifier being at a very different temperature when the two measurements were made, as well as to gain calibration error.

The bandpass is remarkably flat, and the skirts are steep. There are no measurable spurious responses to at least 4.0 GHz.

c. Noise Figure

The test set-up is shown in figure 3. The noise figure shown in figure 1 has been corrected for a 9 db NF second stage contribution.

Although our measured values of N.F. are somewhat higher (about 0.5 db) than those specified on the manufacturer's test data sheet, they are well below the specified 6.0 db maximum.

The manufacturer employs an automatic noise figure meter in their measurements of noise figure. This method has fallen into disuse at NRAO because of insufficient accuracy.

d. Saturation Power Output

The narrow band saturation power output of the amplifier was measured at each end and at the middle of the bandpass. The broadband 1-2 GHz saturation power output was also measured.

TABLE II

Frequency	Saturation Power Output
GHz	dbm
1.0	-1.8
1.4	-0.6
2.0	-2.8
1.0-2.0	-2.0

Figure 6 illustrates the test set-up. The saturation power output curves are shown in figure 7.

II. Gain Stability

a. Supply voltage

With the set-up of figure 3, the variation in noise figure with supply voltage was measured. This result is shown in Table III.

TABLE III

N.F.	V Supply Volts	GHz
4.60	15	1.5
4.50	12	1.5

The noise figure is clearly not adversely effected by power supply voltage changes, for $\frac{\Delta N.F.}{\Delta V} \leq 0.03 \text{ db/V}$.

The change of gain with supply voltage was also measured. The set-up is shown in figure 4 and the results are given in Table IV.

TABLE IV

<u>V Supply</u> <u>Volts</u>	<u>Δ Gain</u> <u>db</u>
13	+0.45
15	0.0
17	-0.16

From this it is seen that $-0.08 \text{ db} < \frac{\Delta G}{\Delta V} < + 0.225 \text{ db}$.

b. Temperature

The largest parameter effecting the amplifier gain is temperature. The set-up was that of figure 5. The amplifier was placed upon a thermoelectric cooling unit using Dow Corning 340 heat sink compound to insure intimate thermal contact. A contact thermistor, also well heat-sinked, was then placed on top of the amplifier to read the case temperature.

By controlling the current to the cooling unit, the amplifier was slowly heated and cooled. The total power output was measured with a digital voltmeter.

TABLE V

Case Temperature °C	E dvm Volts
16.0	1.30
27.9	0.830
47.0	0.385

Since the detector is within its square-law region, $E_{dvm} \sim P$, where P is the total power output.
$$\frac{\Delta P}{\Delta T} = \frac{10 \log \left(\frac{E_{dvm1}}{E_{dvm2}} \right)}{\Delta T}$$

Over the range of 16°C to 47°C, $\frac{\Delta P}{\Delta T} = -0.17 \text{ db/}^\circ\text{C.}$, if we assume $\frac{\Delta P}{\Delta T}$ is linear.

If the change in total power output is ascribed to gain alone, $\Delta P \sim \Delta G$, and $\frac{\Delta G}{\Delta T} = -0.17 \text{ db/}^\circ\text{C.}$, again assuming $\frac{\Delta P}{\Delta T}$ is linear.

c. Input VSWR

In figure 4, the total power output (square-law detector output voltage) was measured with different values of calibrated mis-match at the amplifier input. The results are listed in Table VI.

TABLE VI

Input VSWR	E_{dvm} Volts
∞	0.654
2.0	0.774
1.6	0.807
1.3	0.811
1.0	0.818

It can be seen that for a change in input VSWR of from 2.0 to 1.0 the total power output increases +0.25 db.

d. Attitude

No changes in total power output of the amplifier were noted at any attitude.

e. Magnetic Field

A moderate magnetic field was found to have no measurable effect on the amplifier's total power output.

III. Conclusion

The Avantek AM-1000 solid-state amplifier seems to be suitable for a millimeter-wave radiometer IF amplifier. Its noise figure, bandwidth, and gain compare favorably with the TWTs. Although the initial cost is slightly higher than that of a comparable TWT, its indefinite lifetime would result in a net cost saving.

Size and weight, which are critical in the NRAO 36' telescope package, are greatly reduced with the Avantek amplifier. A not-so-obvious saving in size and weight is also possible by the removal of a 1-2 GHz_z bandpass filter that is presently used between the TWT stages to limit the bandwidth.

The gain stability with temperature and with input VSWR is not as good as a TWT, but the solid-state amplifier is not sensitive to external magnetic fields or nearby ferromagnetic material, as is the case when using traveling wave tubes.

The Avantek AM-1000 should yield stable, predictable performance throughout its unlimited lifetime.

Figure 1

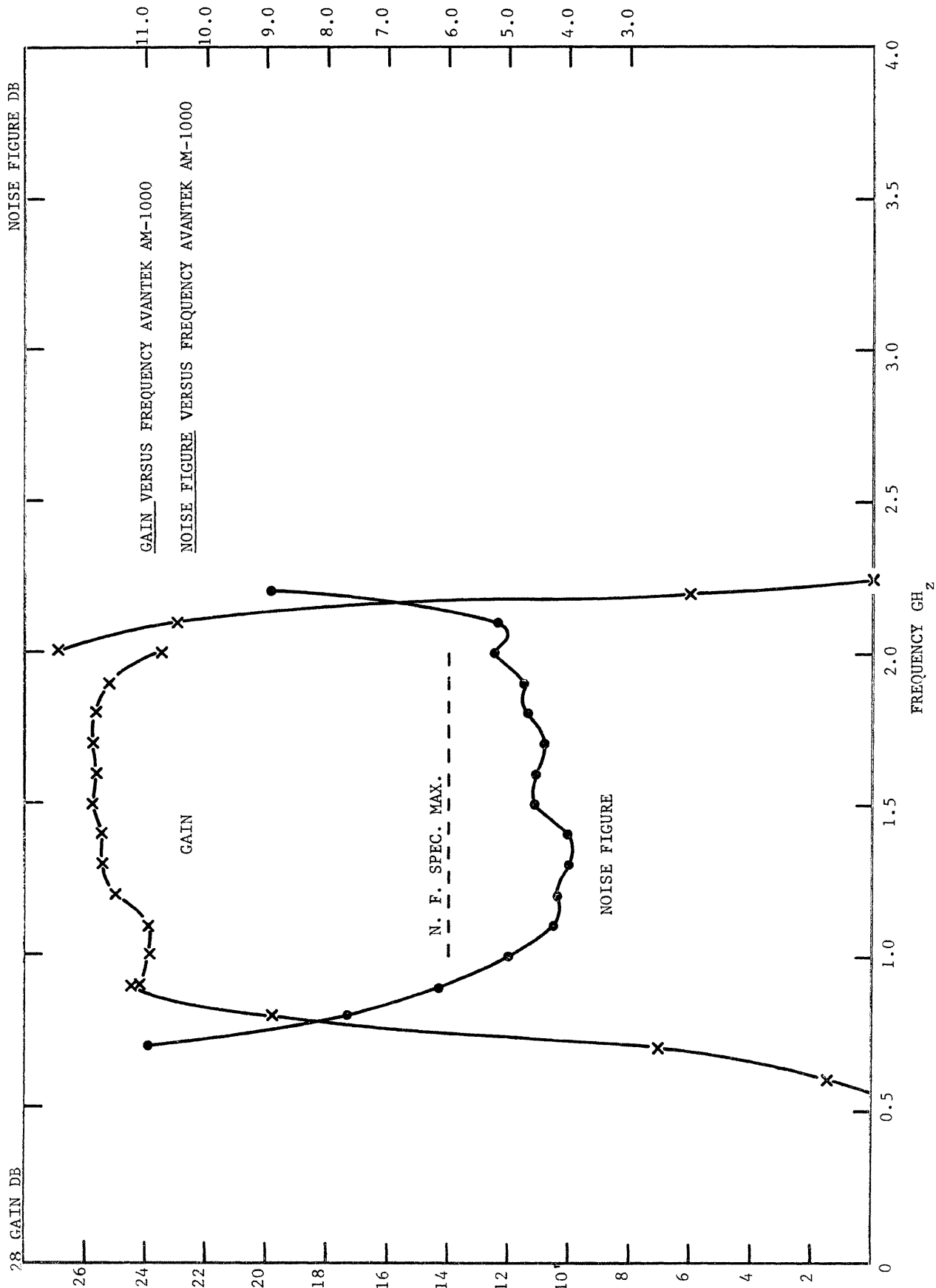

Gain vs. Frequency

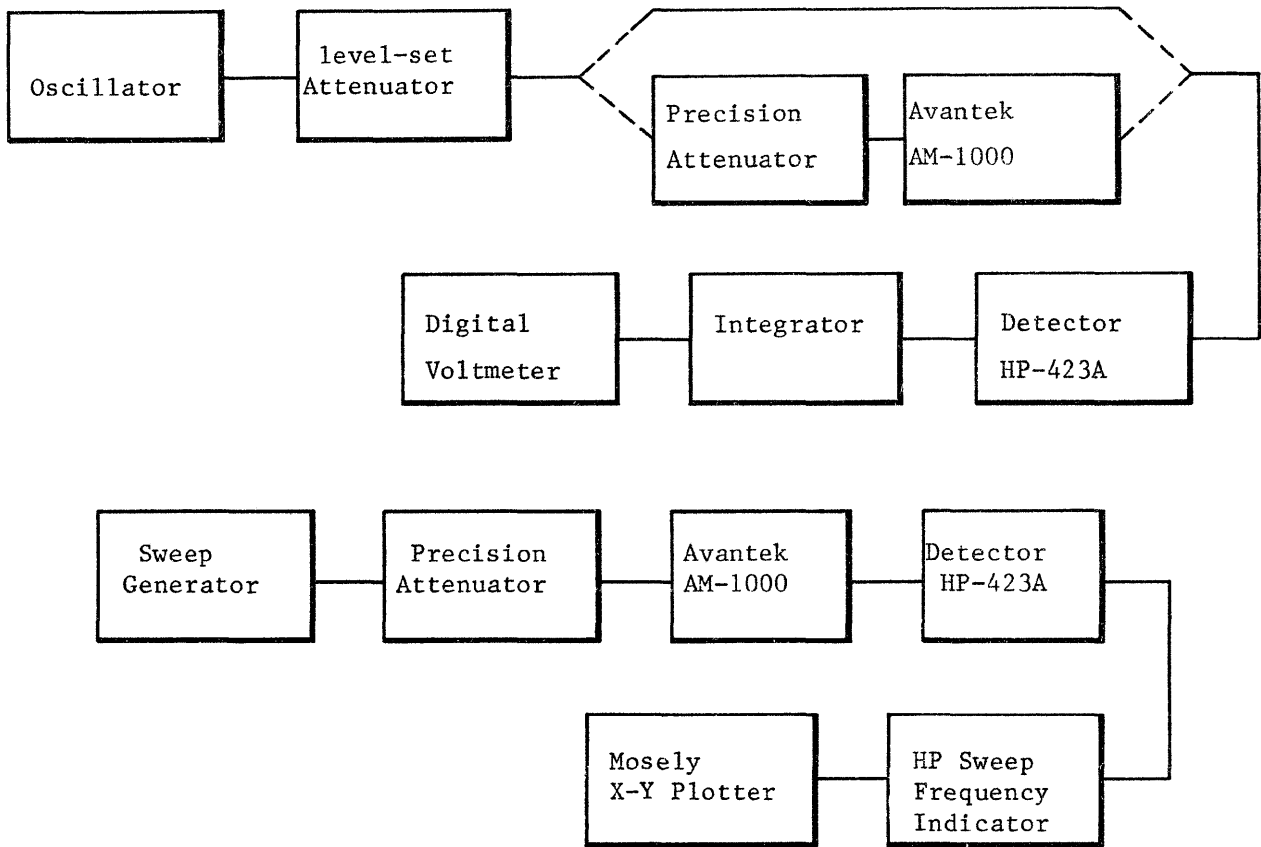

Figure 2

Noise Figure vs. Frequency

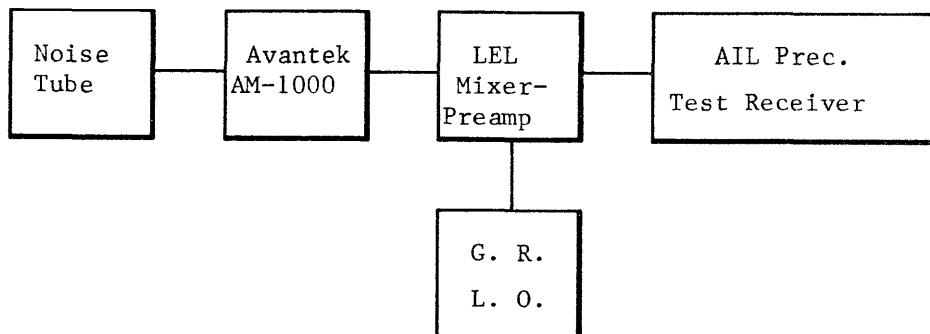

Figure 3

Total Power Output vs. Input VSWR

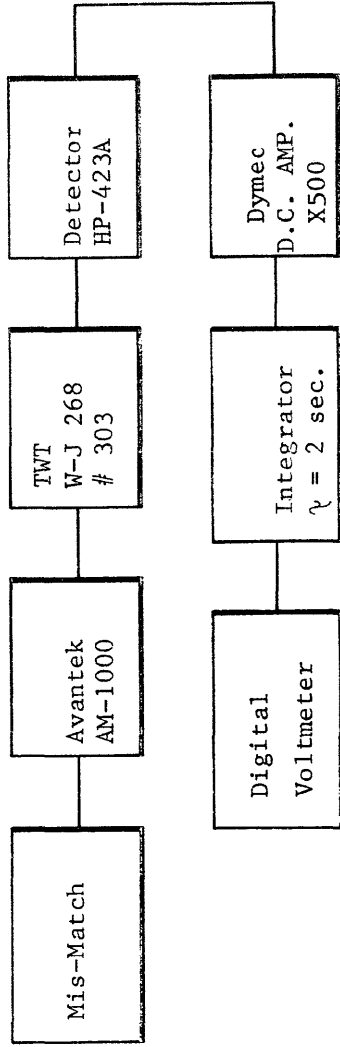

Figure 4

Gain vs. Ambient Temperature

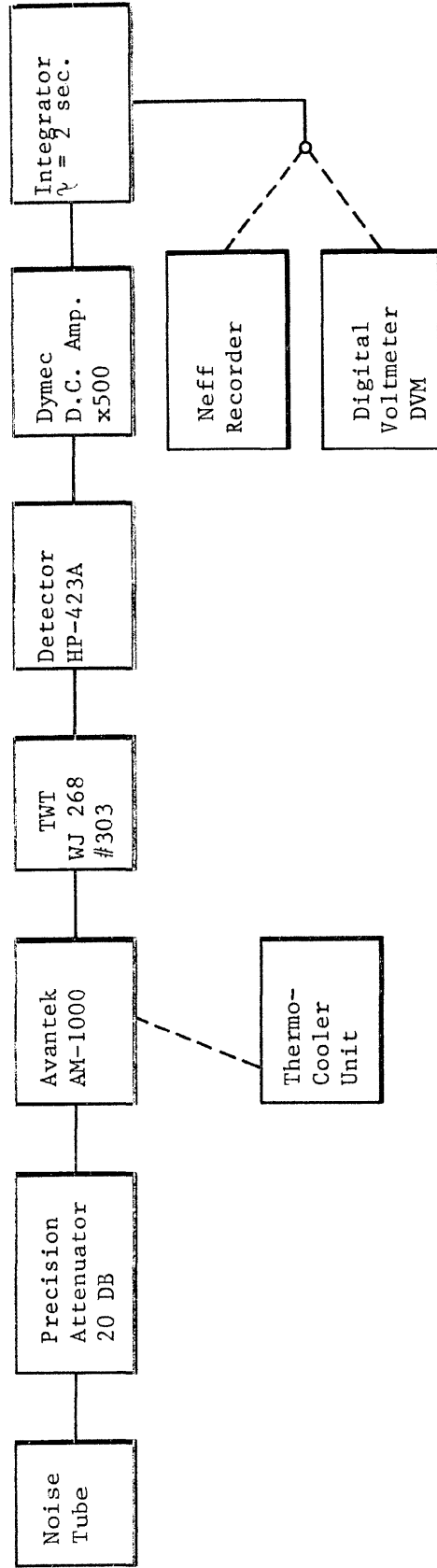
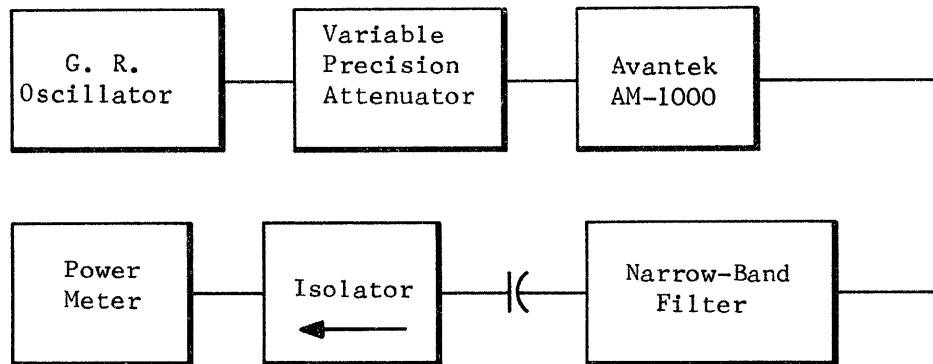
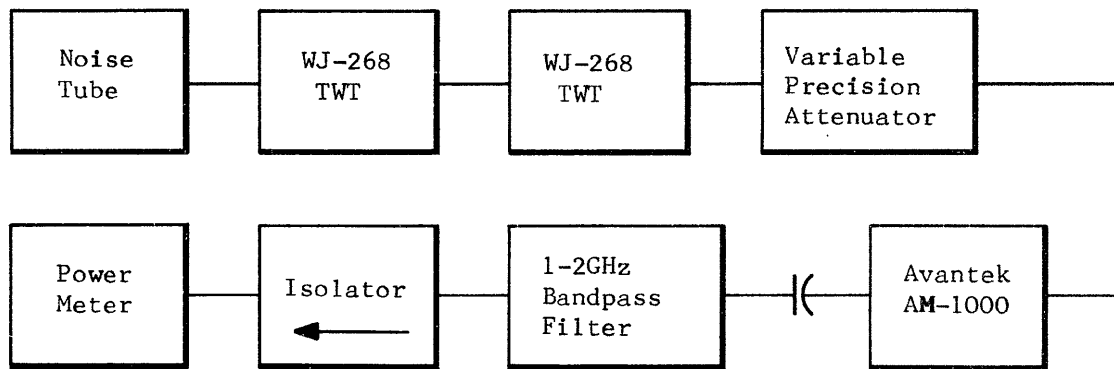

Figure 5



Narrow-Band Saturation Measurement



Wideband Saturation Measurement

FIG. 6

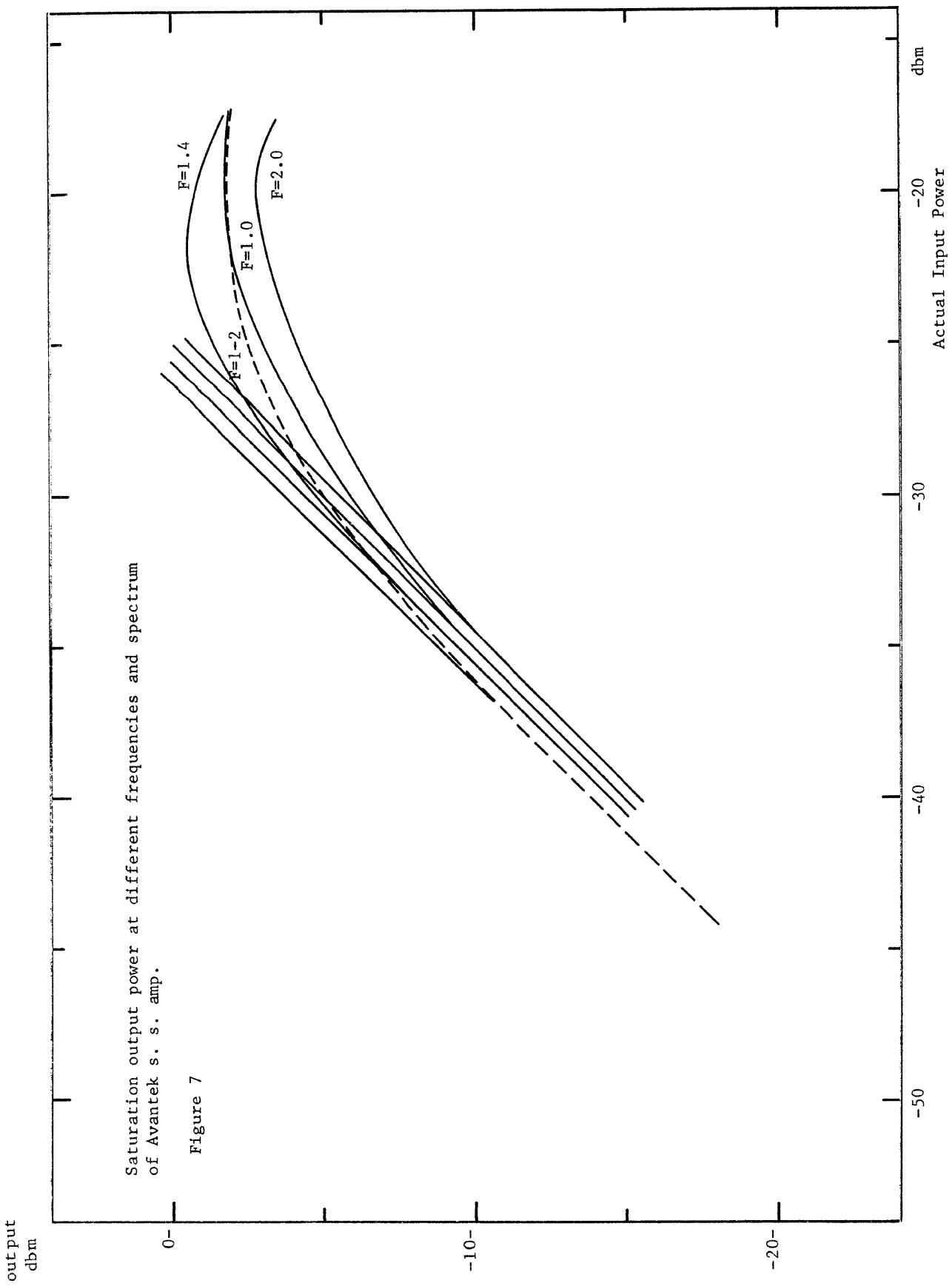

Saturation output power at different frequencies and spectrum of Avantek s. s. amp.

Figure 7