

NATIONAL RADIO ASTRONOMY OBSERVATORY
Green Bank, West Virginia

Electronics Division Internal Report No. 51

INTERFEROMETER RECEIVER BACK END

James R. Coe

JANUARY 1966

NUMBER OF COPIES: 75

TABLE OF CONTENTS

	<u>Page</u>
1.0 GENERAL -----	1
2.0 IF PROCESSING COMPONENTS -----	1
Fig. 7 - Interferometer System Time Delays -----	2
2.1 IF Cable Equalizers -----	2
Fig. 8 - IF Cable Equalizer for 5000' of 1/2" Spiroline -----	3
2.2 IF Patch Panel Module -----	3
2.3 HP 462A IF Amplifier -----	3
2.4 Cable Delay Unit -----	3
Table 1 - Interferometer Delay Characteristics -----	4
2.5 Attenuator Filter Module -----	5
2.6 HP 460AR IF Amplifier -----	6
2.7 Total Power Module -----	6
2.8 TP/AGC DC Amplifier -----	7
3.0 CORRELATING COMPONENTS -----	
3.1 Correlator Module -----	7
3.2 X1 DC Amplifier -----	10
3.3 (A + B) and (A - B) DC Amplifiers -----	10
3.4 Correlator Gain DC Amplifier -----	10
3.5 VFC Input Module -----	11
3.6 Voltage to Frequency Converters -----	11
4.0 TEST AND MONITORING COMPONENTS -----	11
4.1 Distribution Module -----	12
4.2 Monitor Module -----	12
4.3 Oscilloscope -----	13
4.4 Audio Amplifiers -----	13
4.5 Meter Lamp Power Supply -----	13
5.0 AC POWER SYSTEM -----	13
6.0 SETUP PROCEDURE -----	15
6.1 IF Signal Level Adjustments -----	15
6.2 Total Power Module Adjustments -----	15
6.3 Correlator Adjustments -----	16
6.4 VFC Input Module Adjustments -----	17

Continued --

TABLE OF CONTENTS (CONTINUED)

		<u>Page</u>
Fig. 1	Interferometer Receiver Back End Block Diagram -----	18
Fig. 2	Distribution Rack -----	19
Fig. 3	Output Rack -----	20
Fig. 4	LO Rack -----	21
Fig. 5	Cable Delay Unit -----	22
Fig. 6	IF Bandpass -----	23
Fig. 9	IF Patch Panel -----	24
Fig. 10	Bandpass of Delays 0, 1, 2, 3, and 4 -----	25
Fig. 11	Bandpass of Delays 5, 6, 7, and 8 -----	26
Fig. 12	Bandpass of Delays 9 and 9 and 10 -----	27
Fig. 13	2-12 MHz Bandpass Filter -----	28
Fig. 14	Total Power Module Schematic -----	29
Fig. 15	Correlator Module Schematic -----	30, 31
Fig. 16	V/F Converter Input Module Schematic -----	32
Fig. 17	Distribution Module Schematic -----	33
Fig. 18	Monitor Module Schematic -----	34, 35
Fig. 19	Audio Amplifier Schematic -----	36
Fig. 20	Meter Power Supply Schematic -----	37
Fig. 21	Isolation Transformer Module Schematic -----	38

INTERFEROMETER RECEIVER BACK END

James R. Coe

1.0 GENERAL

The interferometer receiver back end is a subsystem of the interferometer system used at NRAO. The receiver back end receives the IF signals from the two telescopes and produces an output signal proportional to the cross-correlation of the two IF signals.

The interferometer receiver back end block diagram is shown in Figure 1. The IF signals received from each telescope are delayed, filtered, amplified, and cross-correlated in the back end. Functionally, the interferometer receiver back end consists of (1) IF processing components, (2) correlating components, and (3) test and monitoring components. These components will be described in detail in the following sections.

The back end components and local oscillator components are housed in 4 standard 19" panel racks located in a trailer on the interferometer baseline. The component layout is shown in Figures 2, 3, 4, and 5. Most of these components are plug-in modules installed in Hewlett-Packard combining cases. In addition, three 24" panel racks are used to house the large coils of cable required in the cable delay unit.

2.0 IF PROCESSING COMPONENTS

These components are used to provide a constant level IF signal with the required time relationship to the correlating system components so that the correlation process can be performed. The IF signals received from the telescopes have a bandwidth from 1 to 20 MHz as shown by Curve A, Figure 6. The bandpass of the IF input to the correlator module is shown by Curve B, Figure 6. These bandpass curves were obtained by sweeping the front end with RF and observing the IF response at the trailer.

The time relationship between the two signals received from the telescopes is dependent upon source position and baseline separation of the two antennas. To obtain the maximum correlator output, the time relationship must be such that the two inputs to the correlator have been delayed for equal times. The simple diagram

shown below will clarify this point.

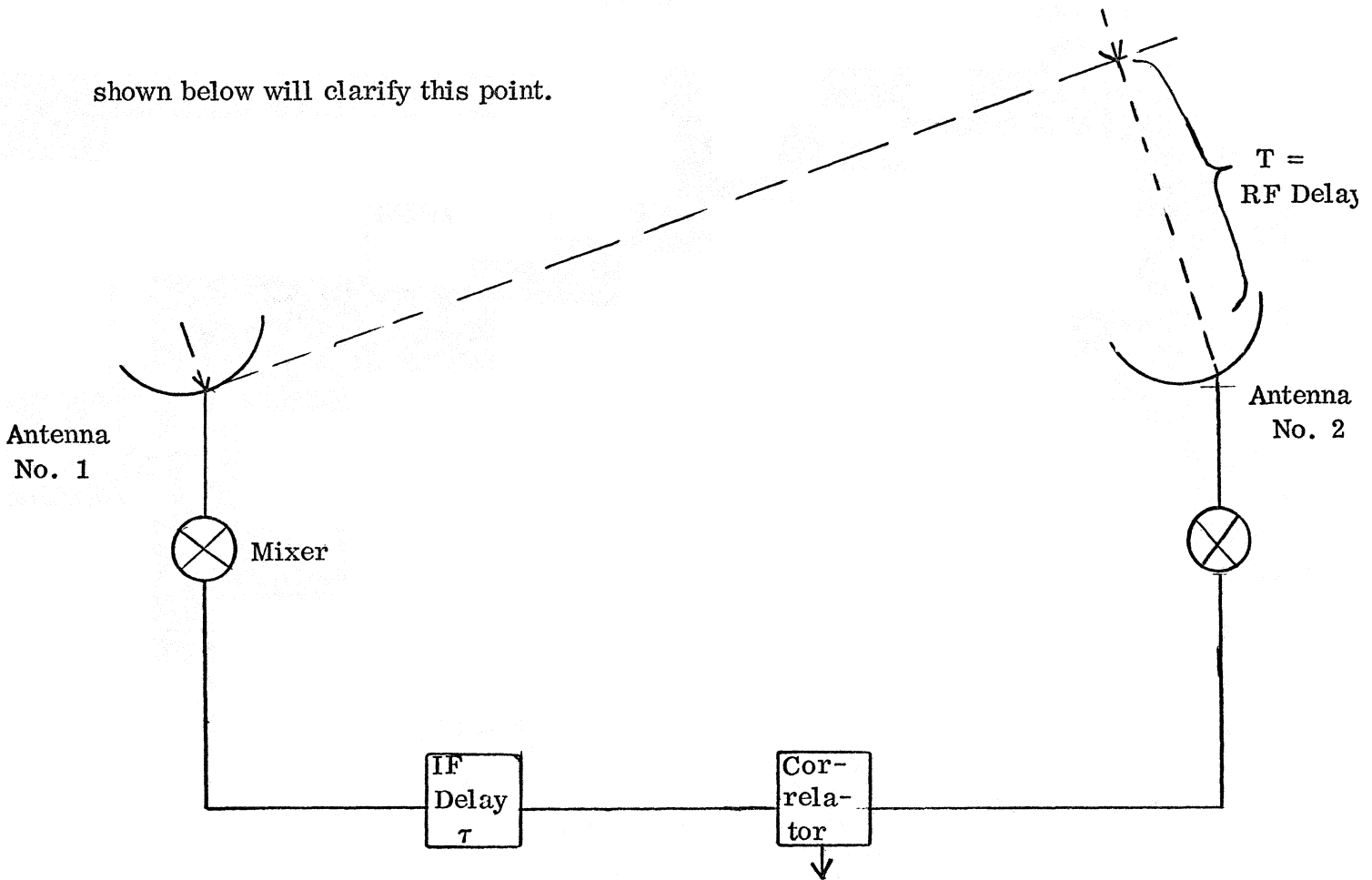

Figure 7. Interferometer System Time Delays

When the IF delay τ is equal to the RF delay T , the maximum output is obtained from the correlator. The IF processing components are programmed to maintain the correct time relationship.

The IF processing components are the IF cable equalizers, the IF patch panel, the HP 462A IF amplifiers, the cable delay unit, the attenuator filter modules, the HP 460 AR IF amplifiers, and the total power modules. The IF signals pass through these components in the order listed above. These components will be described in detail in the following sections.

2.1 IF Cable Equalizers

The IF cable equalizers compensate for the difference in attenuation over the IF bandwidth of the 1/2" Spiroline cable used to connect the IF outputs of the receiver front ends to the interferometer receiver back end. One thousand feet of

1/2" Spiroline has approximately 1 dB loss at 2 MHz and 2.5 dB loss at 12 MHz.

The IF cable equalizer schematic is shown in Figure 8.

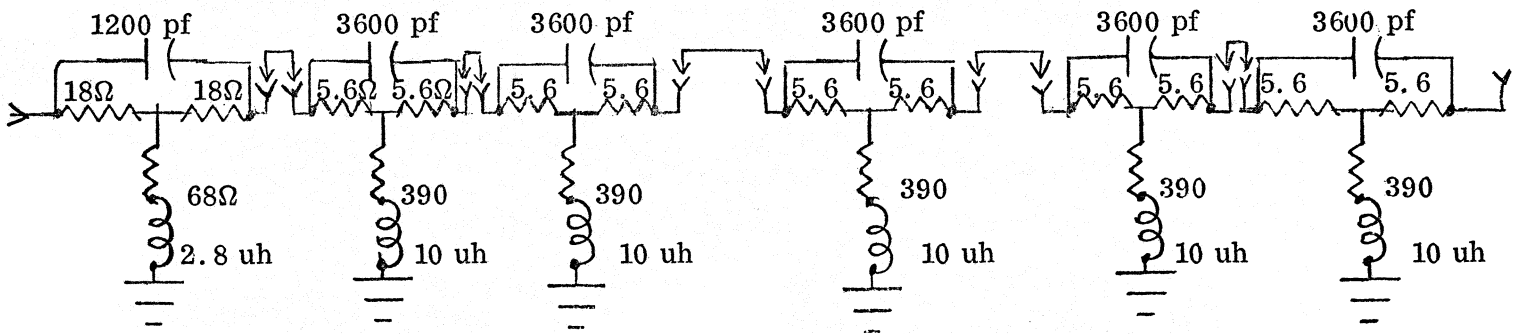

Figure 8. IF Cable Equalizer for 5000' of 1/2" Spiroline

2.2 IF Patch Panel Module

The IF patch panel module contains isolation transformers which isolate the interferometer receiver back end from the grounding system used in the receiver front end at each telescope. These isolation transformers are North Hills Type 0002-FA, 50 ohm unbalanced to 50 ohm unbalanced which have an insertion loss of 1/2 dB over the IF bandwidth of 2 MHz to 12 MHz. The IF patch panel module schematic is shown in Figure 9.

2.3 HP 462A IF Amplifier

The Hewlett Packard Model 462A IF amplifiers are used to increase the level of the IF signal to the distribution module detectors and to the cable delay unit. The 462A amplifiers have 40 dB \pm 1/2 dB gain over the IF passband. These amplifiers are operated in the system with 10 to 15 dB pads at the input and provide overall gains of 25 to 30 dB. Maximum output voltage is \pm .5 volts peak.

2.4 Cable Delay Unit

The cable delay unit provides the IF delays required to balance out the RF delays. The available IF delay is sufficient to compensate for RF delays of any source position from horizon to horizon and at any baseline length up to 2700 meters. The cable delay unit provides IF delays in increments of 11.9 nanoseconds over the range of 0 to 9,107.2 nanoseconds in either IF leg. The delay unit contains

10 individual delays constructed of 1/2" Spiroline cable. These delays are switched in a binary sequence by control signals from the delay switching computer. (See Electronics Division Internal Report No. 41.)

This computer is programmed to keep the RF delay and IF delay equal within ± 5.9 nanosec as the source is tracked across the sky.

The delay characteristics are listed in Table I.

TABLE I
Interferometer Delay Characteristics

Delay Number	Nominal Time Delay	Time Delay Error at 7 MHz	Approximate Length
1	11.9 nanosec	-.2 nanosec	9.5 feet
2	23.8 "	-.6 "	19 "
3	47.5 "	+.2 "	39 "
4	95 "	-.8 "	78 "
5	190 "	+.4 "	156 "
6	380 "	-.4 "	313 "
7	759.9 "	+.8 "	625 "
8	1519.9 "	+.8 "	1250 "
9	3039.7 "	-.8 "	2500 "
10	3039.7 "	-.2 "	2500 "

The bandpass curves for each of the delays are shown in Figures 10, 11, and 12. The cable delay unit is shown in Figure 1, Interferometer Receiver Back End Block Diagram. The arrowheads indicate IF signal flow with the delays in the 85-1 side. The block designated relay bank is used to convert the 0 and -6 V logic signals from the delay switching computer to +12 V DC and -12 V DC diode switch control voltages. The diode switches are Sanders Associates Model DS11A, which is a SPDT switch handling a frequency range of DC to 400 MHz. The isolation when the switch is off is approximately 100 dB within the IF passband of 2 MHz to 12 MHz. The insertion loss with the switch on is approximately 1/2 dB for frequencies within the IF passband. The six switches (Nos. 19, 20, 21, 22, 23, and 24) are used to place the delays in either IF leg. The remaining twenty switches are used in pairs

to route the signal through the individual delay or through the attenuator. The attenuators have insertion losses approximately equal to the loss of the individual delays to reduce amplitude changes in the IF signal when the delays are switched in and out. For example, attenuator No. 10 has 7.6 dB loss which is approximately equal to the loss of the 2500 feet of cable in delay No. 10 plus the loss in equalizer No. 10.

Equalizers Nos. 8, 9, and 10 compensate for the difference in attenuation over the IF passband of delay cables Nos. 8, 9, and 10. These equalizers are similar to the IF cable equalizer shown in Figure 8.

The blocks designated "zero delay" are actually 43 feet of 1/2" Spiroline cable which is approximately equal to the time delay through the diode switches and interconnecting cables with zero delays switched in.

The diode switch delay equalizers provide a time delay vs. frequency response which is equal to the time delay vs. frequency response of the twenty diode switches connecting the individual delays. The diode switches do not have a constant time delay across the IF passband and these equalizers are required to provide the same time delay vs. frequency characteristic when the signals are routed through the delay path or the zero delay path.

The HP 461A IF amplifier is used to make up for the 33 dB loss through the delay cable system. The amplifier gain is set at 40 dB and attenuator No. 11 is a 7 dB pad. The HP 461A amplifier has characteristics similar to the HP 462A amplifier described in section 2.3. The phase reversing transformer corrects for the 180° phase reversal through the HP 461A IF amplifier. A single point ground is connected to the cable delay unit through the HP 461A IF amplifier power line.

2.5 Attenuator-Filter Module

The attenuator-filter module contains a HP 355C VHF attenuator, a North Hills 0002FA isolation transformer, and a NRAO designed bandpass filter. The attenuator is adjustable from 0 to 12 dB in one dB steps and is used to adjust the IF level into the total power module and the correlator module. The isolation transformer isolates the cable delay unit ground from the attenuator filter module ground. The bandpass filter is a 10 pole elliptic function filter which limits the IF passband to 10 MHz. The schematic and attenuation characteristic are shown in Figure 13.

2.6 HP 460AR IF Amplifier

The Hewlett-Packard Model 460AR amplifier is a distributed tube-type amplifier. When used with the North Hills Model 0502 DC, 50 ohm to 200 ohm, matching transformer, this amplifier provides a maximum of 20 dB gain. The amplifier may be gain-controlled by varying the amplitude of the negative voltage on the grids of the tubes. As used in the present system, this amplifier can compensate for decreases in signal level of 6 dB and increases in signal level of 12 dB.

2.7 Total Power Module

The total power module amplifies and monitors the IF signal level and provides the required gain control signal to the HP 460AR IF amplifier to maintain a constant level IF signal into the correlator module. The total power module schematic is shown in Figure 14.

The C-COR Model 3029 IF amplifier provides 20 dB gain with a maximum output level of 10 V peak-to-peak. The gain is flat within ± 0.5 dB over the IF passband of 2 MHz to 12 MHz.

The ISO-T splits the output of the C-COR amplifier and feeds half of the power to the correlator module and the other half to the Hewlett-Packard Model 423A detector. A visual indication of IF signal level is provided by the 0-1 milliamperere detector current meter, which monitors the output of the detector. The detector output is also recorded on the 4 channel strip chart recorder after being amplified by the TP/AGC DC amplifier. When the automatic level control switch on the monitor module is placed in the ON position, the output of TP/AGC amplifier is fed back to the total power module and added to the IF gain control voltage to complete the automatic level control loop.

The IF gain control provides for fine adjustment of the IF signal level into the total power and correlator modules by changing the gain control voltage to the HP 460AR IF amplifier.

The balance control provides a variable DC voltage in series with the total power detector output. This control is adjusted to provide zero detected output when the IF signal is at the desired level. When the ALC switch is ON, any change in IF signal from this desired level will produce an output voltage which is amplified by

the TP/AGC amplifier and added to the gain control voltage to change the gain of the HP 460AR IF amplifier.

For example, if the IF signal into the HP 423A detector increases, a more positive signal is produced at the output of the detector. This causes the input voltage to the TP/AGC DC amplifier to go from zero to some positive level. The DC amplifier amplifies and inverts this signal to produce a negative voltage output. This negative voltage is added to the gain control voltage and applied to the grids of the tubes in the HP 460AR IF amplifier which reduces its gain and restores the IF signal to its original level.

2.8 TP/AGC DC Amplifier

The TP/AGC DC amplifier is a Dymec Model 2460A with a DY-2461A-M2 plug-in. This amplifier is operated at a gain of 1100 when the ALC switch is ON and at 110 when the ALC switch is OFF. The amplifier has a maximum output of ± 10 volts.

3.0 CORRELATING COMPONENTS

The purpose of the correlating components is to obtain an output signal proportional to the product of the correlatable part of the two IF signals.

The correlating components are the correlator module, the A + B and A - B DC amplifiers, the X1 DC amplifiers, and the correlator gain DC amplifier.

3.1 Correlator Module

The correlator module schematic is shown in Figure 15. The blocks designated ISO-T are Adams-Russell Model TH-50 binary power dividers. The ISO-T's are used for splitting or addition of the IF signals.

The isolation transformers are North Hills Model 800BB. These units are 50 ohm unbalanced to 800 ohm balanced transformers. They are used in the correlator module in pairs to obtain phase inversion of one component signal.

The two detectors used in the correlator module are Hewlett-Packard Model HP 423A negative output and HP 423A positive output. These detectors are used with

matched loads to provide square law outputs.

The A + B and A - B balance controls provide a small DC voltage (14 mV max) which subtracts from the two detector outputs and is used to match the detector response.

In order to describe the correlation process the voltage of the IF signal from one telescope is designated A and from the other telescope B. The IF signal voltages A and B are split in the first ISO-T's to give the signal voltages

$$\frac{A}{\sqrt{2}}, \quad \frac{A}{\sqrt{2}}, \quad \frac{B}{\sqrt{2}}, \quad \text{and} \quad \frac{B}{\sqrt{2}}.$$

Each of these voltages passes through the North Hills 800BB isolation transformers where one voltage is inverted to give the signal voltages

$$\frac{A}{\sqrt{2}} \quad \frac{A}{\sqrt{2}} \quad \frac{B}{\sqrt{2}} \quad \text{and} \quad -\frac{B}{\sqrt{2}}.$$

These signals are added in the second set of ISO-T's to give the two outputs

$$\left(\frac{A}{\sqrt{2}} + \frac{B}{\sqrt{2}} \right) \quad \text{and} \quad \left(\frac{A}{\sqrt{2}} - \frac{B}{\sqrt{2}} \right).$$

Each of these outputs is detected using the positive and negative square law detectors. The square law detectors have output voltages of

$$K_1 \frac{(A+B)^2}{2} \quad \text{and} \quad K_2 \frac{(A-B)^2}{2}$$

where K_1 and K_2 are fixed constants determined by the individual detector efficiency.

The outputs of the two detectors are amplified by the A + B and A - B DC amplifiers.

The gain of these amplifiers is adjusted to $\frac{N}{K_1}$ and $\frac{N}{K_2}$ to give equal outputs of

$$N \frac{(A+B)^2}{2} \quad \text{and} \quad -N \frac{(A-B)^2}{2}.$$

These outputs are added in the resistor adder network to give an output of

$$N \left[\frac{(A + B)^2}{2} - \frac{(A - B)^2}{2} \right]$$

This expression may be expanded to give

$$- \frac{N}{2} \left[A^2 + 2AB + B^2 - A^2 + 2AB - B^2 \right]$$

which is then reduced to $2N(AB)$. It is apparent this output $2N(AB)$ is proportional to the product of the IF signals and thus is the desired correlated output.

The AC-DC coupling network in the correlator module — with the switch in the AC position — is a differentiating network which attenuates very low frequency components of the correlated output. These low frequency components are produced by the combination of spurious outputs from the LO system feeding through both mixers and the phase relationship between these signals being changed at the delay switching rate. The following table gives the attenuation and phase shift of the correlator output at several frequencies due to the AC coupling network where

$T = 5\mu f \times 10 \text{ meg} = 50 \text{ sec.}$

Frequency	ωT	Attenuation = $\frac{1}{\sqrt{1 + (\omega T)^2}}$	Phase shift = $\tan^{-1} \left(\frac{1}{\omega T} \right)$
2 Hz	628	0.16%	6 minutes
1 Hz	314	0.32%	11 minutes
.5 Hz	157	0.64%	22 minutes
.1 Hz	31.4	3.2 %	1° 50 minutes
.01 Hz	3.14	30.3 %	17° 40 minutes
.001 Hz	.314	95.6 %	72° 30 minutes

When the AC-DC coupling switch is in the DC position the capacitor is by-passed and no attenuation or phase shift in the correlated output occurs.

After the correlator output signal passes through the AC-DC coupling network, it is fed to the X1 DC amplifier in the correlator module, and then to the correlator gain DC amplifier.

The .02 second time constant is used to prevent saturation of the correlator gain DC amplifier by transients.

3.2 X1 DC Amplifier

The X1 DC amplifier provides an input impedance of 10^{10} ohms and acts as a buffer amplifier to prevent loading of the AC coupling network. This amplifier is a Dymec Model 2460A with a DY-2461A-M4 plug-in.

3.3 (A + B) and (A - B) DC Amplifiers

The A + B DC amplifier is used to amplify the output of the positive detector in the correlator module. This amplifier is a Dymec Model 2460A with a 2461A-M2 plug-in. The gain of this amplifier is set at 67 for normal operation.

The A - B amplifier is the same type amplifier. It is used to amplify the output of the negative detector in the correlator module. The gain of this amplifier is set at 100 for normal operation.

The difference in gains of the DC amplifiers are due to differences in detector efficiency.

The outputs of the A + B and A - B amplifiers are monitored on the 0 to 1 milliamperere amplifier output meter on the correlator module. When no correlated signal is present the amplifier output meter reads the same (typically .55 MA) for both the A + B and A - B positions indicating the correlator is balanced with these gain settings.

3.4 Correlator Gain DC Amplifier

The correlator gain DC amplifier amplifies the correlator output after the .02 sec time constant and drives the voltage to frequency converter after passing through the VFC input module. The output of this DC amplifier is also fed through a .1 sec time constant in the monitor module and then to the strip chart recorders. The correlator gain DC amplifier is a Dymec 2460A with DY 2461A-M2 plug-in. A gain of 15 is used for strong sources and 150 for the weaker sources.

3.5 VFC Input Module

The voltage-to-frequency converters can only process positive input signals. The correlated output signal out of the correlator gain DC amplifier swings positive and negative. The VFC input module offsets the correlator output signal to make the signal into the (ϕ) VF converter positive. The VFC input module schematic is shown in Figure 16. As shown in the schematic the VFC input module has a voltage divider which reduces the correlator output voltage from ± 10 V max to ± 1.25 V max. A +1.4 V DC offset voltage is added to this signal so that the input to the VF converter is always positive. The input signal to the VF converter varies from +.15 V min to +2.65 V max.

The VFC input module also processes the IF signal level voltages from the distribution module detector's DC amplifiers. A voltage divider reduces the voltage level to 5 V max. The TP1 and TP2 offset controls have been disconnected and are no longer used. The two IF level signal voltages are alternately connected to the (TP) VF converter for one second intervals by the relays in the VF converter input module.

3.6 Voltage to Frequency Converters

The two voltage to frequency converters used in the interferometer receiver back end are Vidar Models 260B with 10 kHz full scale output. The one labeled ϕ VF converter is used for processing the correlator output signal and the TP VF converter for the IF level signals from the distribution module detector's DC amplifiers.

The outputs of the VF converters are converted to binary data in the digital output system and recorded on magnetic tape.

4.0 TEST AND MONITORING COMPONENTS

The test and monitoring components are used to monitor IF signal levels, test battery voltages, and aid in identifying interfering signals. The test and monitoring components are the (1) distribution module and DC amplifier, (2) monitor module, (3) oscilloscope, and (4) audio amplifier.

4.1 Distribution Module

The distribution module schematic is shown on Figure 17. This module contains an ISO-T and a HP 423A negative detector to monitor the IF signal level before it passes through the cable delay unit. Any changes in IF signal level at this point are due to changes in the interferometer receiver front end, the IF cable system, or the HP 462A IF amplifiers. The distribution module detector current meter provides a visual indication of IF signal level. The output of the detector is also amplified and fed to the VFC input module, the VF converter, and the digital output system to provide a continuous record of IF signal level from the telescopes during observations.

4.2 Monitor Module

The monitor module is used to check the voltages of the batteries in the offset, balance, and gain control circuits in the various modules. The schematic is shown in Figure 18. Series resistors limit monitor module meter current to .67 MA at full battery voltages. The table below lists switch positions and the functions monitored.

Switch Position	Function	Meter Reading
No. 1	Spare	0
No. 2	A - B balance voltage correlator module	.67 MA
No. 3	Fixed IF gain control voltage 85-2 total power module	.67 MA
No. 4	Variable IF gain control voltage 85-2 total power module	.67 MA
No. 5	Balance voltage 85-2 total power module	.67 MA
No. 6	Spare	0
No. 7	ϕ Offset voltage VFC input module	.67 MA
No. 8	Spare	0
No. 9	Balance voltage 85-1 total power module	.67 MA
No. 10	Variable IF gain control voltage 85-1 total power module	.67 MA
No. 11	Fixed IF gain control voltage 85-1 total power module	.67 MA
No. 12	A + B balance voltage correlator module	.67 MA

The monitor module also contains the ALC switch which completes the ALC loops when placed in the ON position.

A time constant with settings of .02, .05, .1, .2, .5 and 1.0 seconds is built into the monitor module. The correlator output to the strip chart recorders is integrated by this time constant. The time constant is normally set at 0.1 seconds.

4.3 Oscilloscope

The oscilloscope is a Tektronix Model 561.

The oscilloscope is used to monitor the AC component of the detected IF signal level out of the total power modules. The oscilloscope is a visual aid in identifying disturbances on the IF signal level such as interference. The output of the total power module detectors is capacitively coupled to the oscilloscope by the .1 mfd capacitors in series with the center conductor and shield in the patch panel. These capacitors isolate the oscilloscope ground from the total power module detector grounds.

4.4 Audio Amplifiers

The audio amplifiers are also connected to the detected IF signal level in the total power module. The schematic is shown in Figure 19. The audio amplifiers assist in identifying any interference which may be present on the IF signals.

4.5 Meter Lamp Power Supply

The meter lamp power supplies provide 6 V DC for the lamps in the Weston meters in the correlation module, the total power modules, and the distribution modules. The schematic is shown in Figure 20.

5.0 AC POWER SYSTEM

Two 10 amp Sorensons are used to provide 120 V AC regulated power to the interferometer receiver back end and local oscillator components. Isolation transformers are used to isolate the individual modules from power line conducted interference.

The isolation transformers are UTC Models HIT-1 (60 watt output), HIT-15 (150 watt output), and HIT-3 (480 watt output). (See Figure 21.)

Seven of the isolation transformers are mounted in the LO rack. See Figure 4. Each of the three modules contain a HIT-1 and a HIT-15 isolation transformer. The power distributions from these isolation transformers are shown below.

Isolating Transformer Module I (LO Rack)

HIT-1 supplies: .4 amps for 85-2 HP 460AR IF amplifier
HIT-15 supplies: .9 amps for 32 V DC Kepco power supply for
C-COR amps
.3 amp for 6 DC amplifiers in output rack

Isolating Transformer Module II (LO Rack)

HIT-1 supplies: .4 amp for 85-1 HP 460AR IF amplifier
HIT-15 supplies: for cable delay unit (1 amp).

Isolating Transformer Module III (LO Rack)

HIT-1 supplies: .25 amp for TP VF converter
.25 amp for ϕ VF converter
HIT-15 supplies: 1 amp for HP counter

One HIT-3 isolation transformer is located in the rear of the LO rack and supplies 1.0 amperes to the 85-2 C-COR LO amplifier.

The other four isolation transformers are housed in modules in the distribution rack. (See Figure 2.)

Isolating Transformer Module IV (Distribution Rack)

HIT-1 supplies: .4 amp to 2 HP 462I amplifiers
.1 amp to 2 DC amplifiers in distribution rack
HIT-15 supplies: .5 amp to 2 audio amplifiers in distribution rack
.25 amp to meter lamp power supply in
distribution rack.

The following two modules contain HIT-3 isolation transformers:

Isolating Transformer Module I (Distribution Rack)

HIT-3 supplies: .8 amp to oscillator synchrnoizer
 .9 amp to HP signal generator
 1.0 amp to 85-1 C-COR LO amplifier.

Isolating Transformer Module II (Distribution Rack)

HIT-3 supplies: 1.9 amps to oscilloscope
 .5 amp to 2 audio amplifiers in output rack
 .25 amp to meter lamp supply in output rack.

6.0 SETUP PROCEDURE

It is necessary to adjust the interferometer receiver back end controls periodically in order to compensate for changes in the IF signal levels from the telescopes. All adjustments should be recorded in the interferometer operating log.

6.1 IF Signal Input Level Adjustments

The attenuators on the input to the HP 462A IF amplifiers should be adjusted so the distribution module detector currents are between .05 and .1 milliamperes. Any higher level may saturate the IF amplifiers in the back end.

6.2 Total Power Module Adjustments

The IF signal level into the total power and correlator modules should be adjusted so that the detector current meter reads .15 milliamperes. The procedure to be used is as follows:

- (1) Set 0000 delays in 85-1 (east) leg.
- (2) Place the ALC switch on the monitor module in the OFF position.
- (3) Set the IF gain controls on the total power modules to 000.
- (4) Adjust the attenuator on the attenuator filter to obtain approximately .15 milliamperes detector current.
- (5) Use the IF gain control to obtain precisely .15 milliamperes detector current reading. The IF gain control setting should be between 000 and 010.

- (6) Place the ALC switch in the ON position.
- (7) Check to see if the gain of the TP/AGC DC amplifiers is 11×100 .
- (8) Adjust the BALANCE control on the total power module to obtain a detector current reading of .15 milliamperes with the ALC on. The BALANCE control settings should be between 110 and 130.

6.3 Correlator Adjustment

The A + B and A - B amplifier outputs must be equal if the correlator is to operate satisfactorily. The adjustment procedure is given below:

- (1) Set the IF signal level into the correlator as outlined in sections 6.1 and 6.2.
- (2) Place the AC-DC coupling switch in the DC position.
- (3) Switch the correlated output strip chart recorder preamp off and position the pen in the center of the chart. Turn the pre-amp back on.
- (4) Set the gain of the A - B DC amplifier to 10×10 .
- (5) Adjust the gain of the A + B DC amplifier while monitoring the correlator output pen on the strip chart recorder until the pen is centered on the chart. The A + B DC amplifier gain should be approximately 6.7×100 .
- (6) Place the ALC switch in the OFF position. Check that the total power module detector current meters still read .15 milliamperes.
- (7) Alternately change the attenuators in 85-1 and 85-2 attenuator filter modules + and - 3 dB while monitoring the correlator output on the strip chart recorder. Adjust the A + B and A - B balance controls and the A + B amplifier gain to obtain minimum changes in correlator output with the 3 dB changes in IF level. Typical settings are A + B balance setting of 100 and A - B balance settings of 150.
- (8) The correlated gain DC amplifier is operated at a gain of 1.5×100 normally. This gain is reduced to 1.5×10 for the stronger sources.

6.4 VFC Input Module Adjustments

The ϕ offset control on the VFC input module is adjusted to give a count of four on the digital output system Nixie tube marked FRINGE when no correlated output is present. To check and adjust this, place the multiplier switch on the correlated gain DC amplifier to X0 and monitor the FRINGE Nixie tube count. Adjust the ϕ OFFSET control to obtain a count of 4. The setting of this control is normally 1000 (fully clockwise).

FIG. 1 INTERFEROMETER RECEIVER BACKEND BLOCK DIAGRAM

IF FROM 7F-2 FRONT END

IF FROM 85-1 FRONT END

IF CABLE EQUALIZER

IF CABLE EQUALIZER

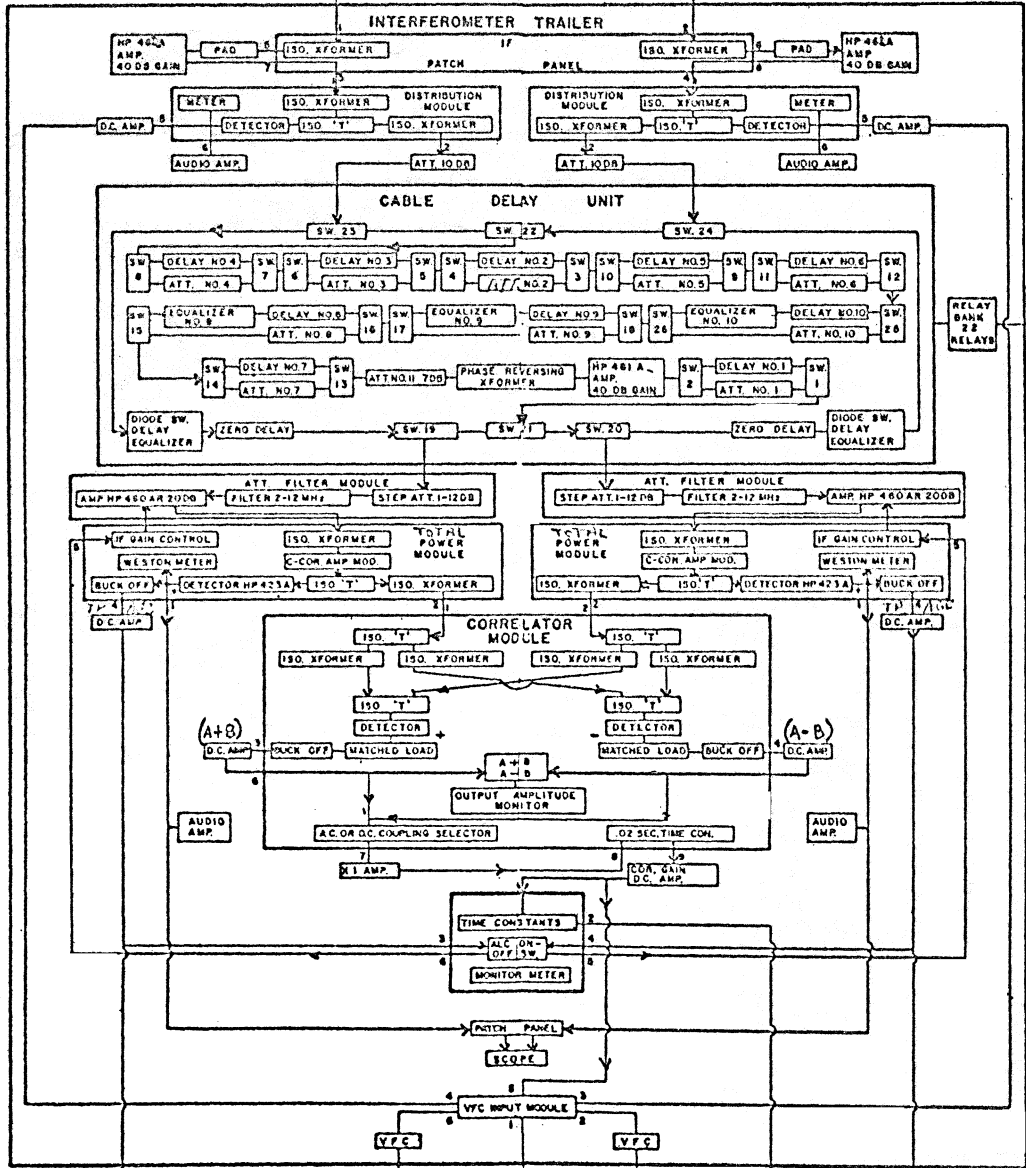

CONTROL SIGNAL FROM DELAY SWITCHING COMPUTER

TO DIGITAL OUTPUT SYSTEM

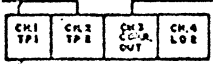

SLOW RECORDER 8 MM/MS.

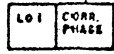

FAST RECORDER 30 MM/MS.

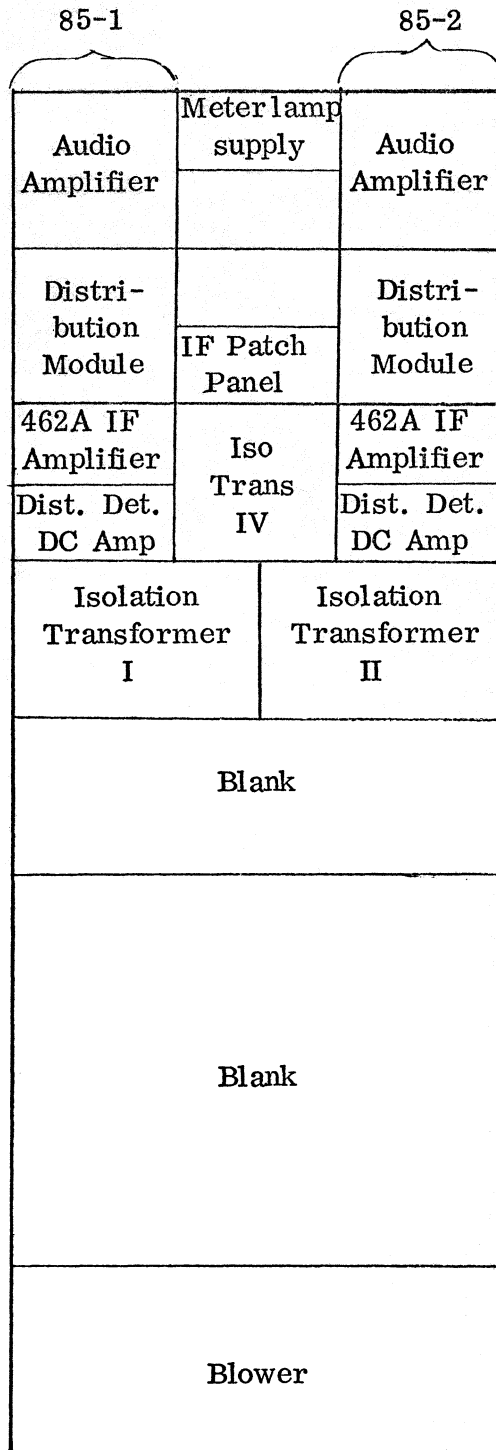

Figure 2. Distribution Rack

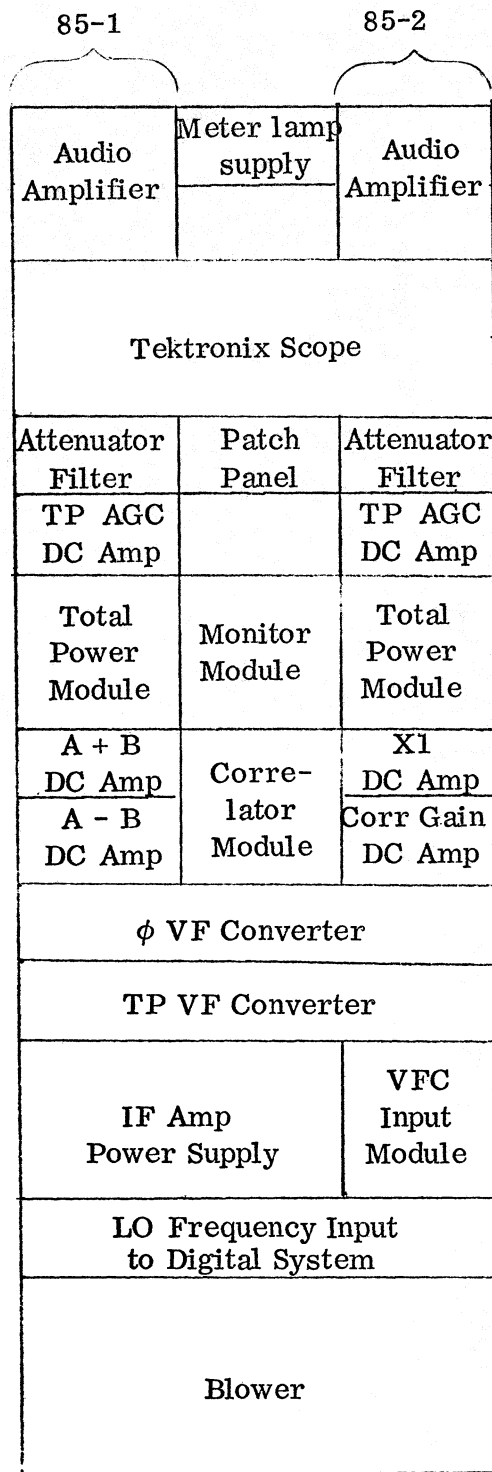

Figure 3. Output Rack

Blank		
HP 5245L Frequency Counter		
85-2 C-COR LO Amp		
85-1 C-COR LO Amp		
Isolation Trans. II	Isolation Trans. III	Isolation Trans. I
HP 8614A Signal Generator		
LO Monitor and Distribution		
Blank		
DY 2650A Oscillator Synchronizer		
Blank		
Blower		

Figure 4. LO Rack

- 12 V DC Diode Switch Power Supply	+ 12 V DC Diode Switch Power Supply
Relay Panel	
IF Inputs	
Delay Cable	
Delay Cable	
HP 461A IF Amplifier	
IF Output Panel	
Delay Indicator Lights Power Supply	

Figure 5. Cable Delay Unit

85-2

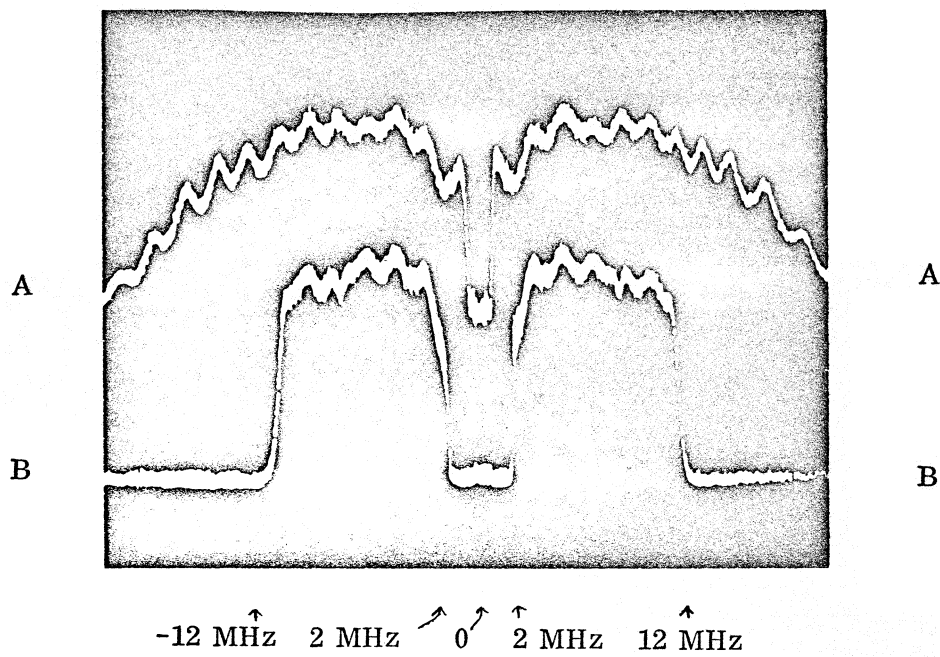

Figure 6. IF Bandpass

Curve A — IF Received from Telescopes.

Curve B — IF Input to Correlator.

Note: These bandpass curves were obtained by sweeping the front end with RF and observing the IF response at the trailer.

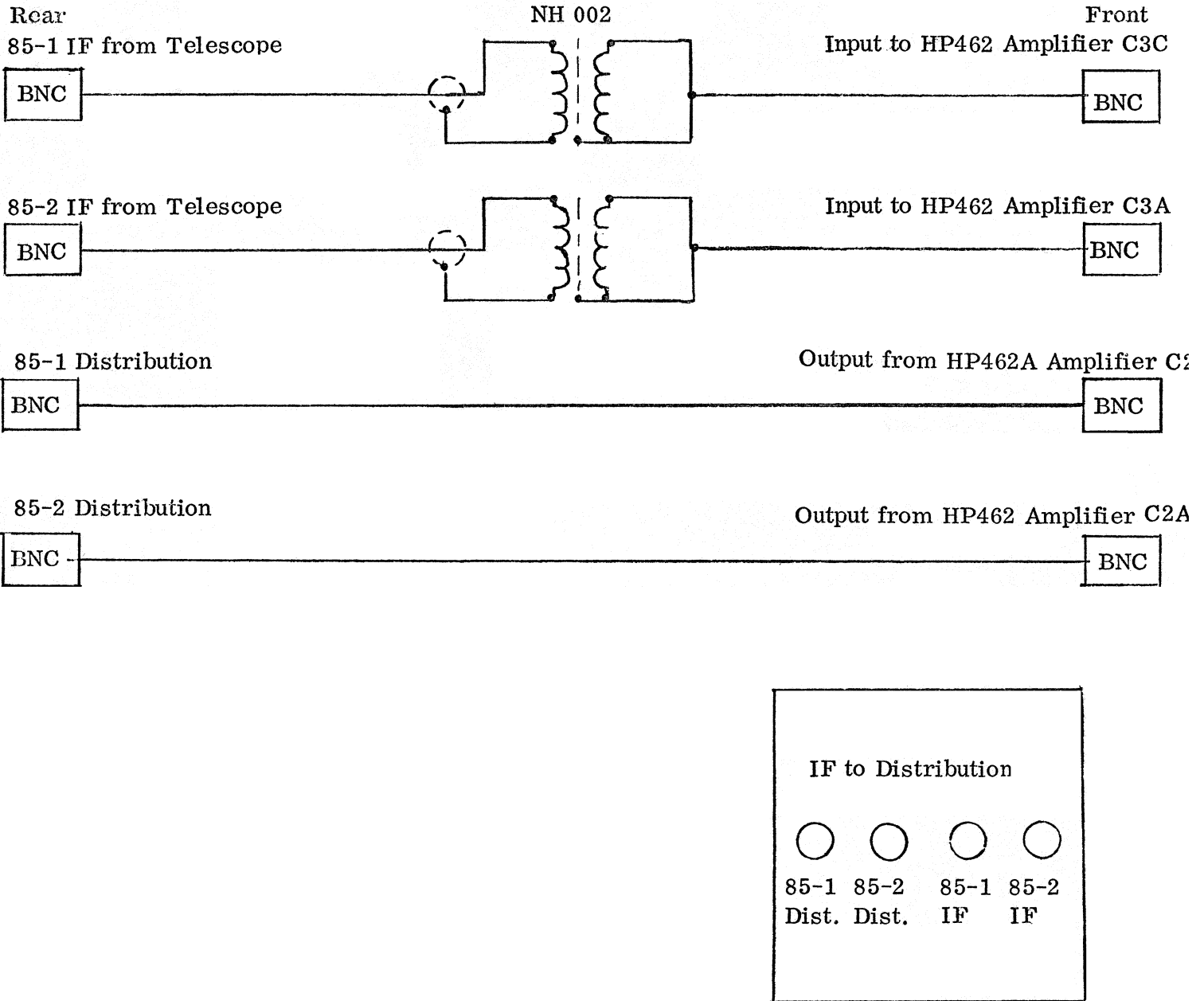
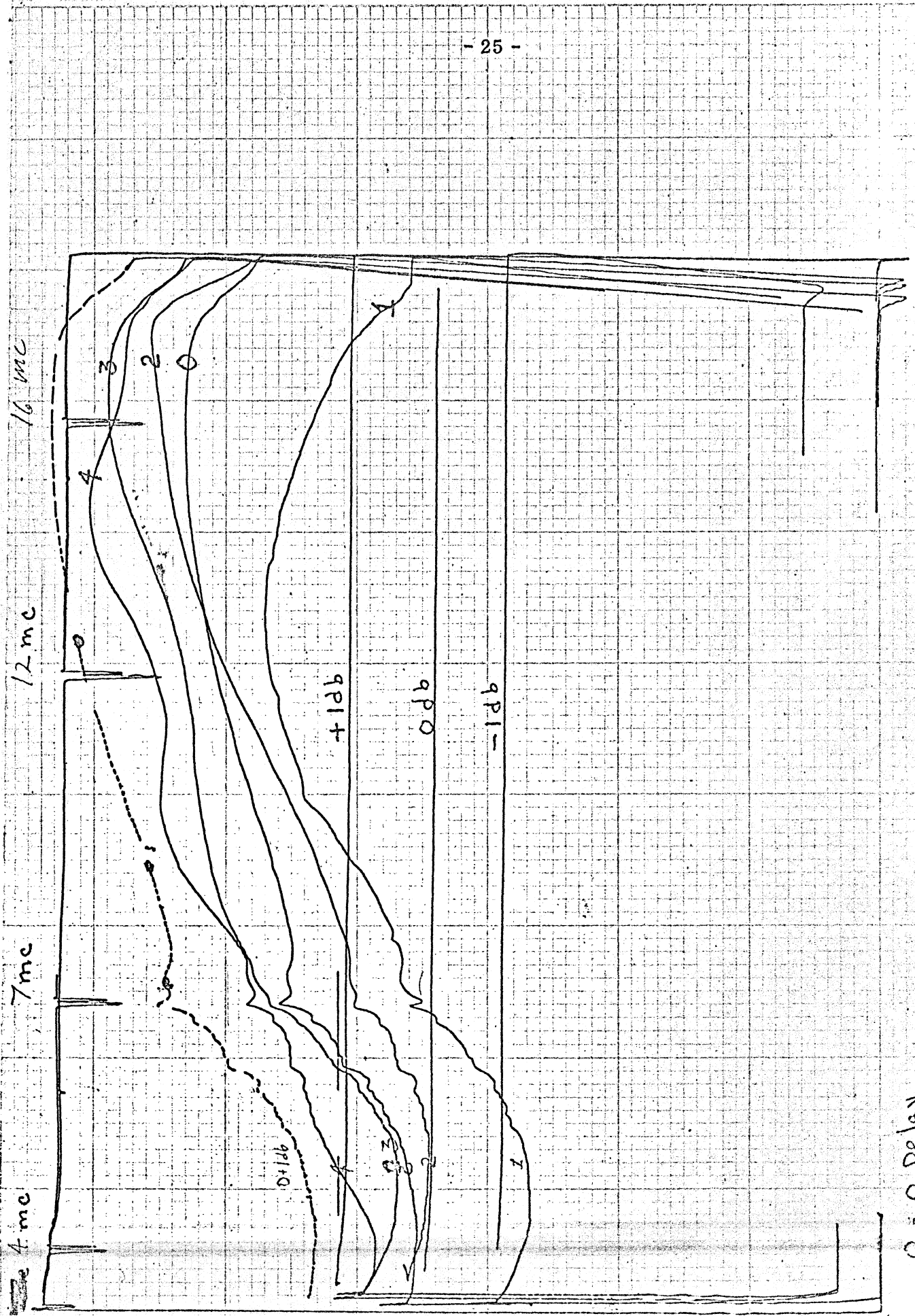

Figure 9. IF Patch Panel

Figure 10. Bandpass of Delays 0, 1, 2, 3, and 4



- 0 = 0 Delay
- 1 = Delay #1
- 2 = Delay #2
- 3 = Delay #3
- 4 = Delay #4

Sept 28, 1965

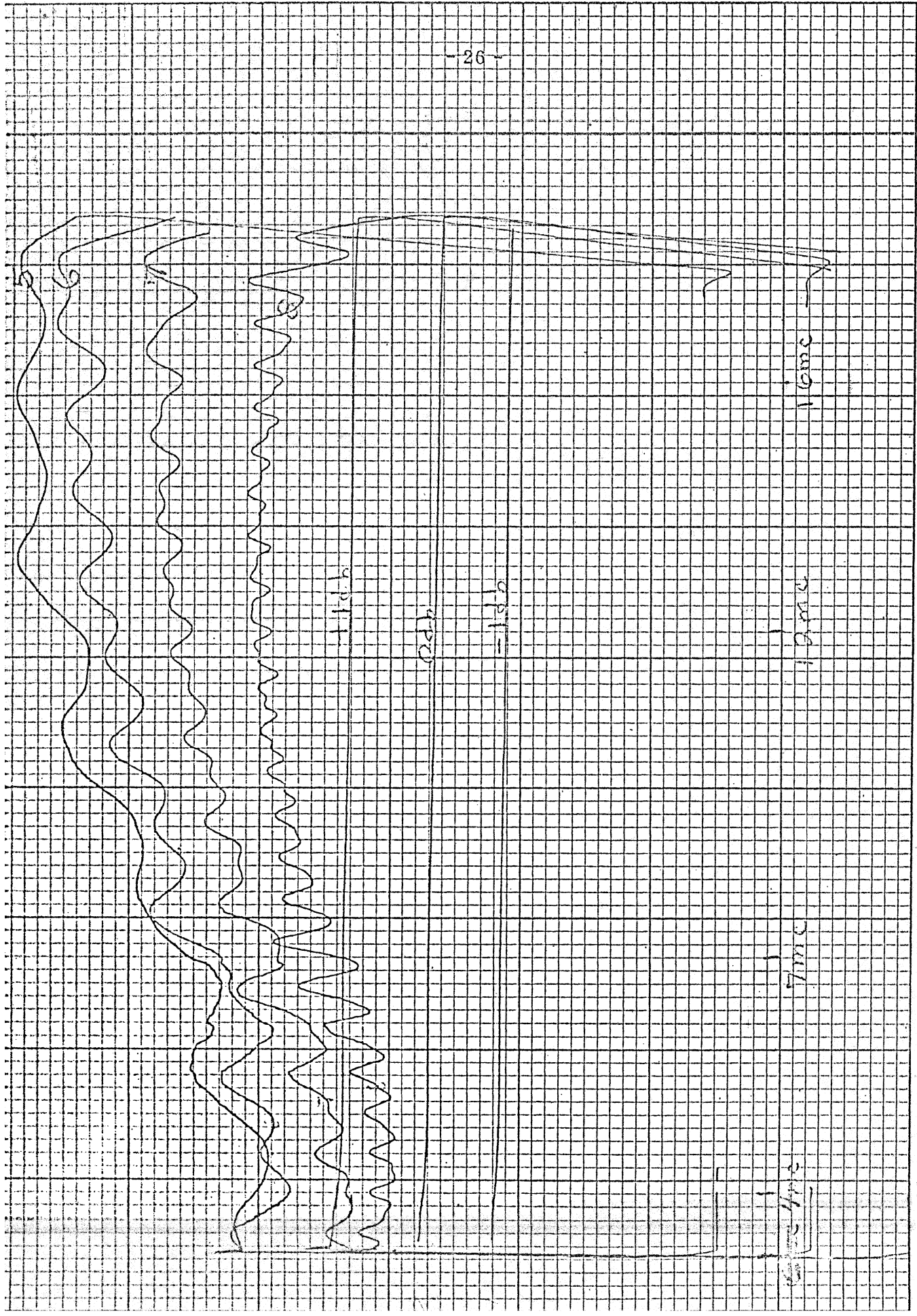

Sept 28, 1965

5 = Delay #5
 6 = Delay #6
 7 = Delay #7
 8 = Delay #8

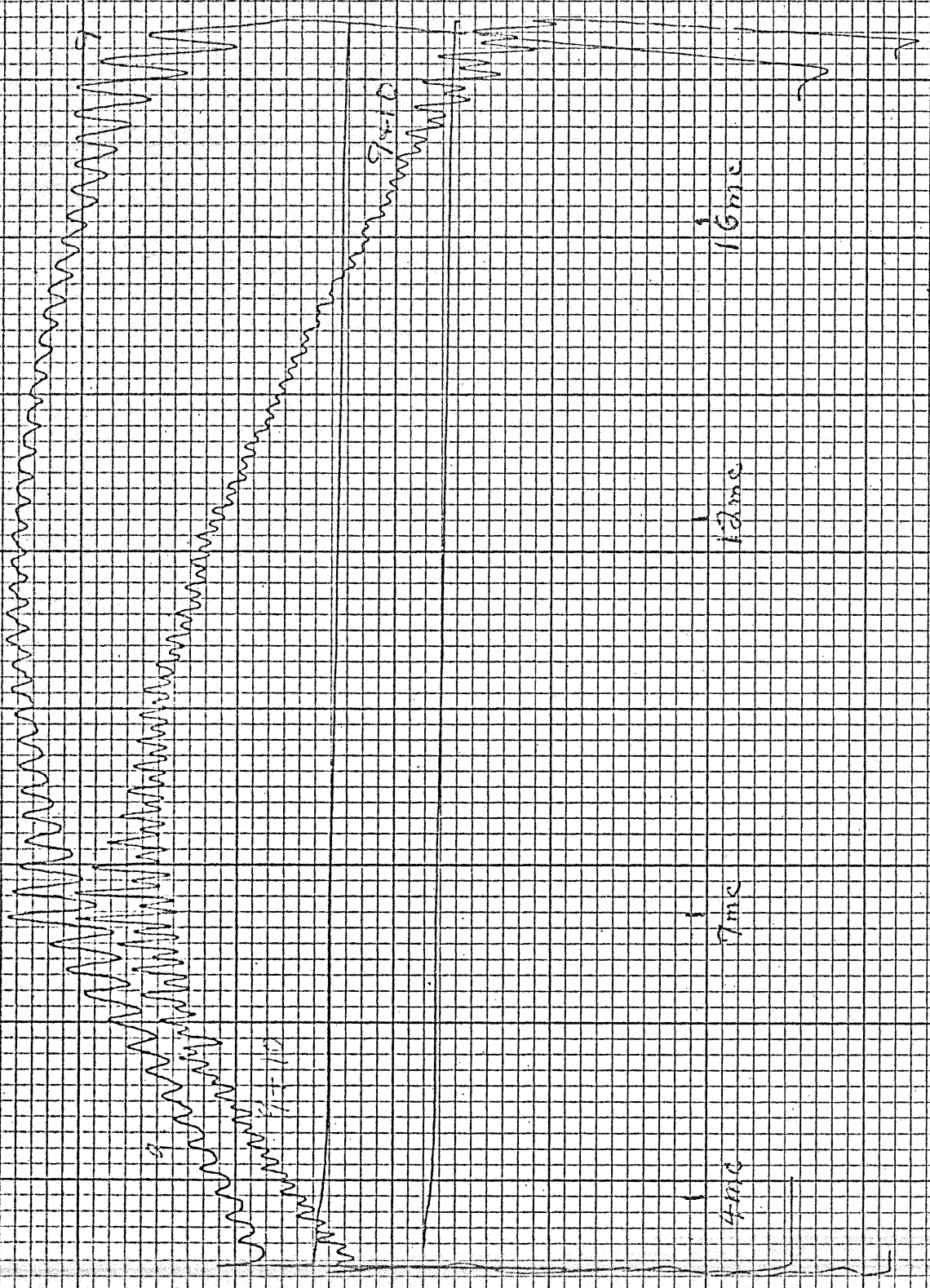

Sept 28, 1963

9 = Delay # 9
9+10 = Delay # 9+10

Figure 13. 2-12 MHz Bandpass Filter
Attenuation vs. Frequency

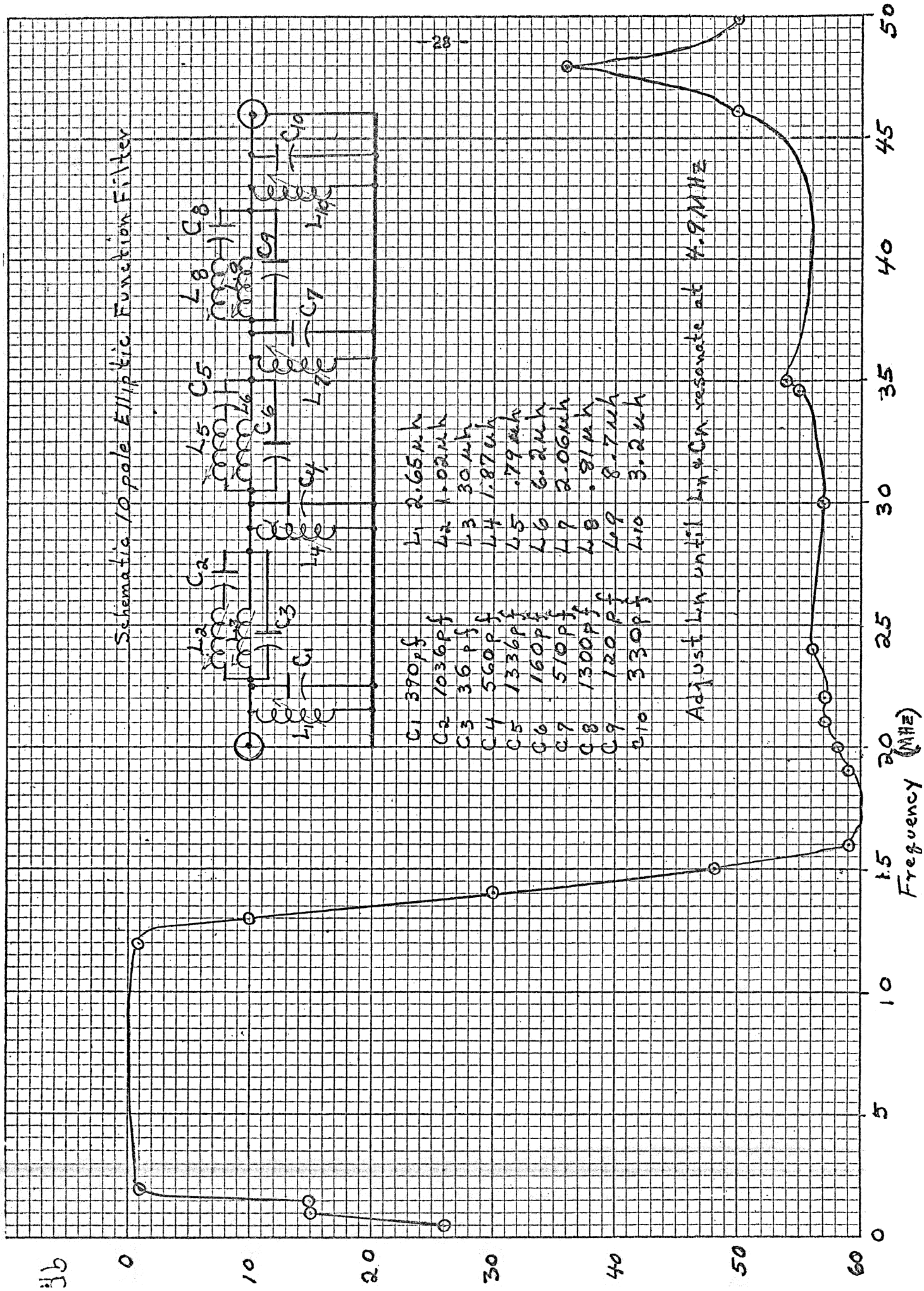

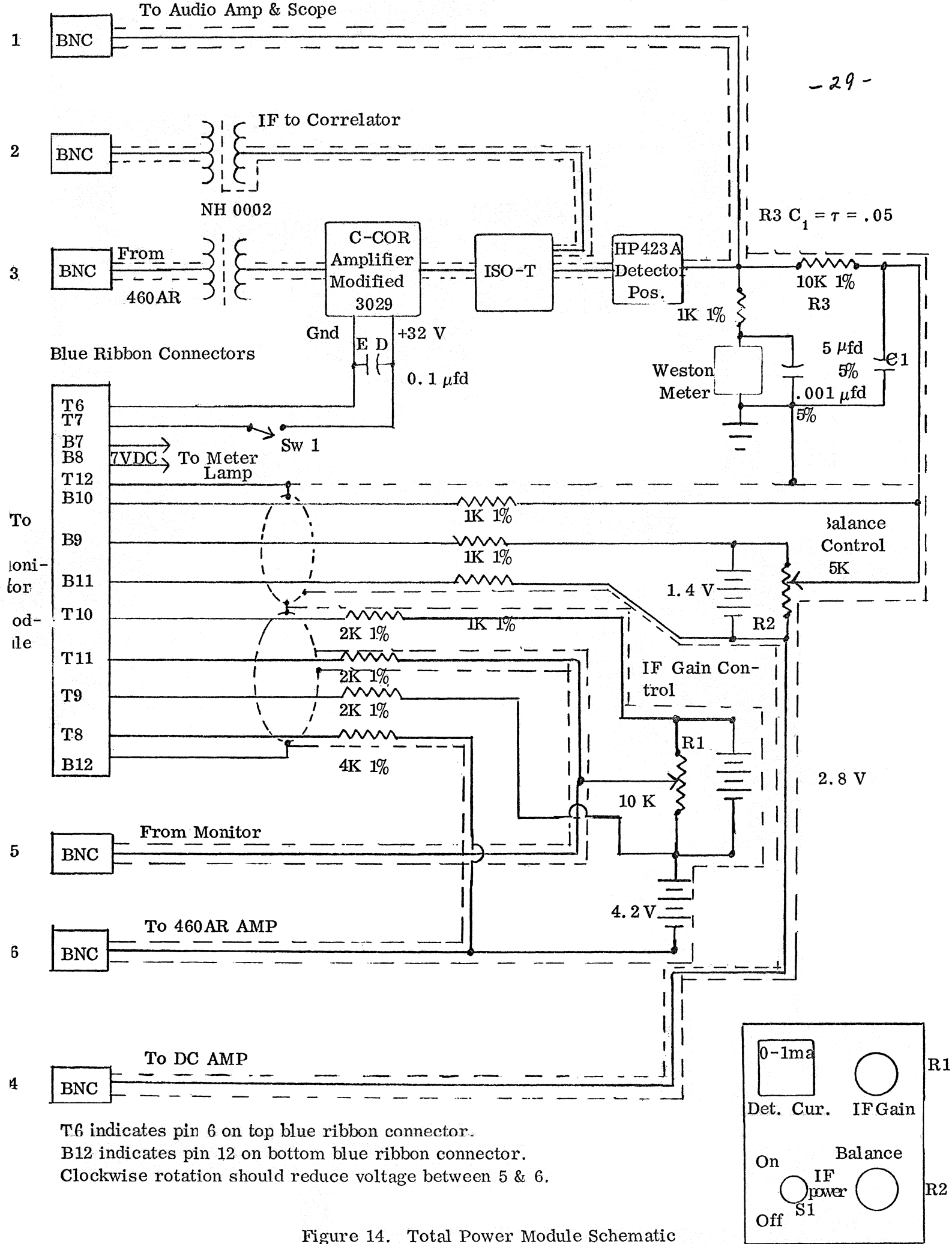

T6 indicates pin 6 on top blue ribbon connector.
 B12 indicates pin 12 on bottom blue ribbon connector.
 Clockwise rotation should reduce voltage between 5 & 6.

Figure 14. Total Power Module Schematic

North Hills Trans.

800BB

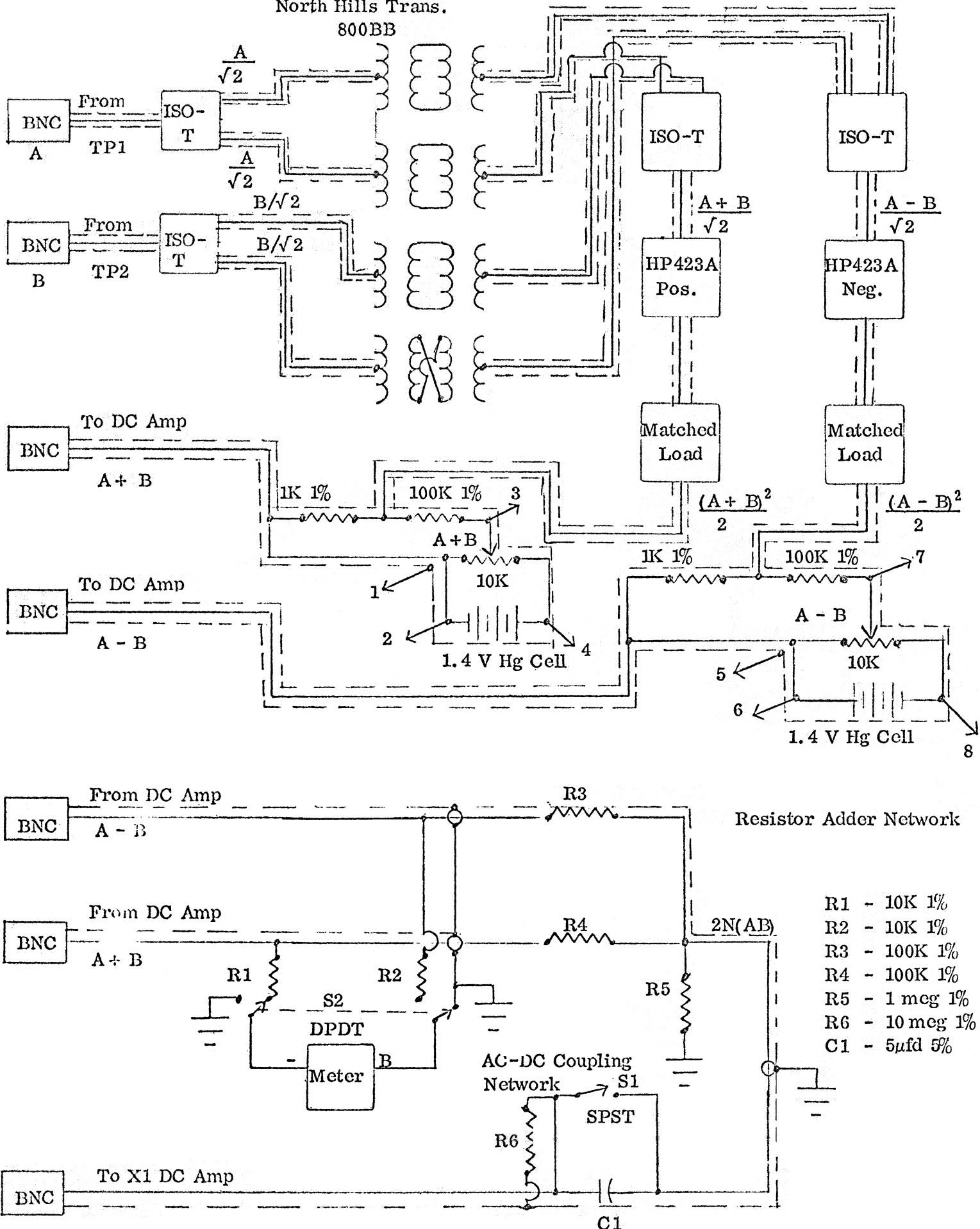
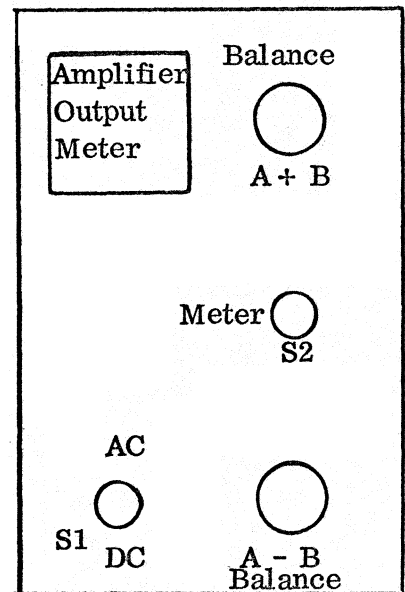
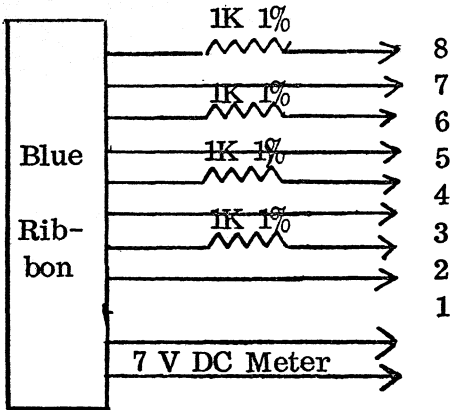
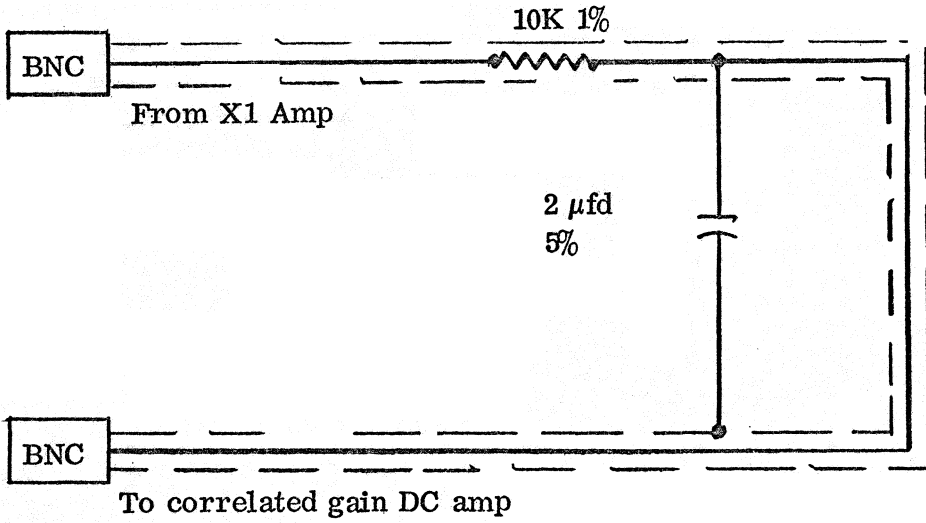

Figure 15. Correlator Module Schematic

Figure 15 (continued)



1 sec square wave

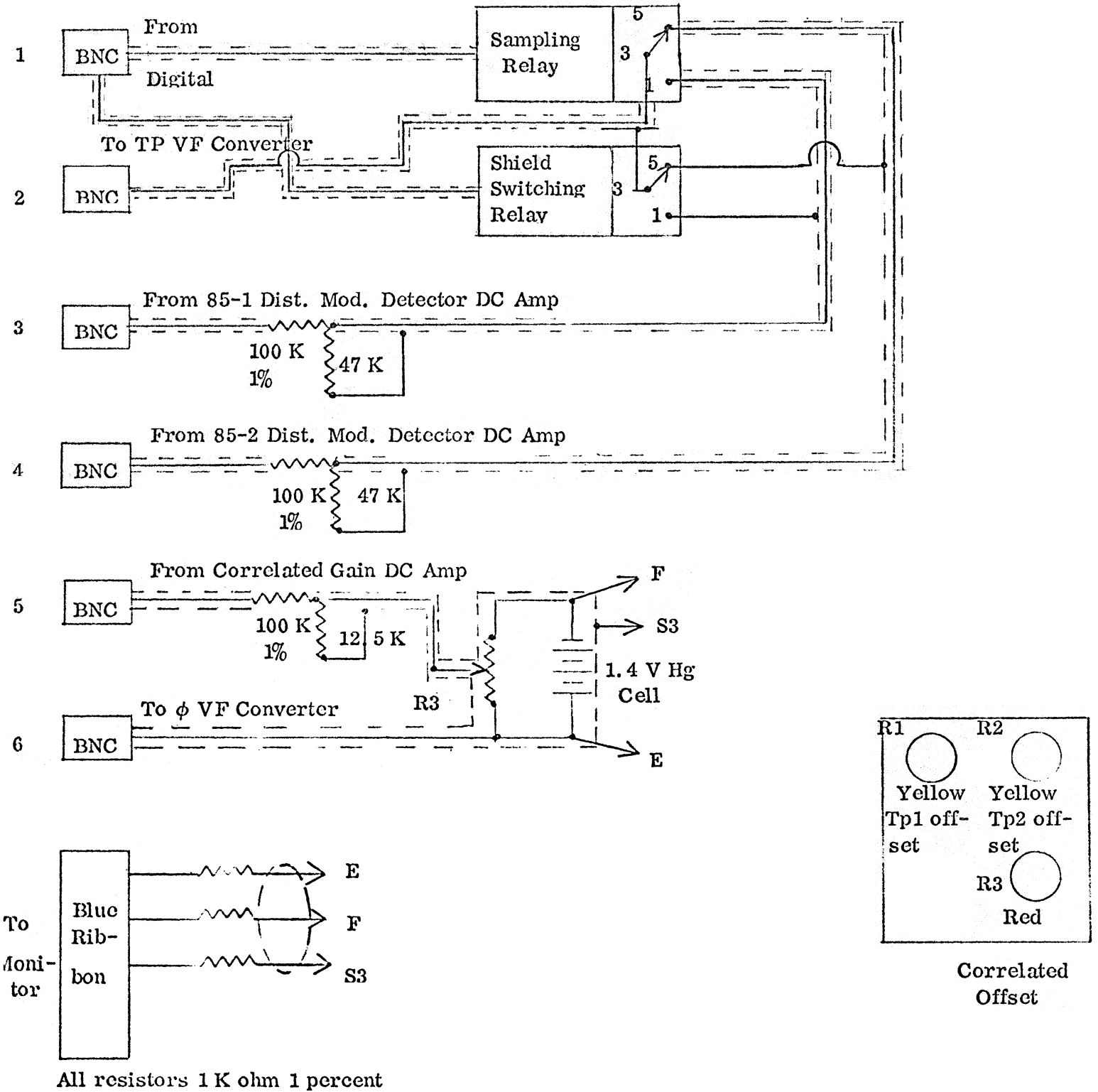

Figure 16. V/F Converter Input Module

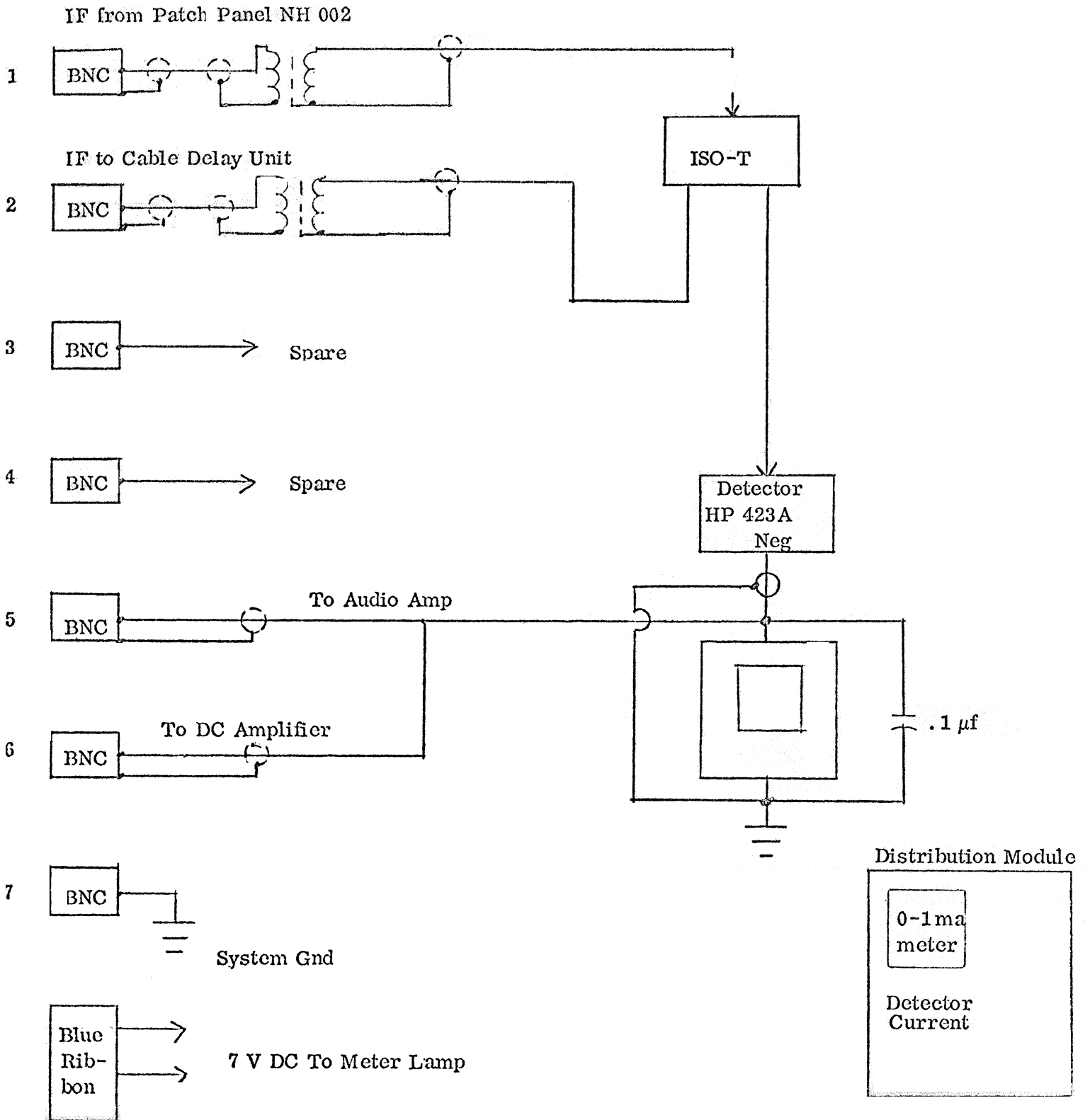

Figure 17. Distribution Module

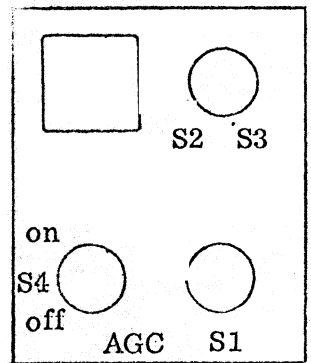
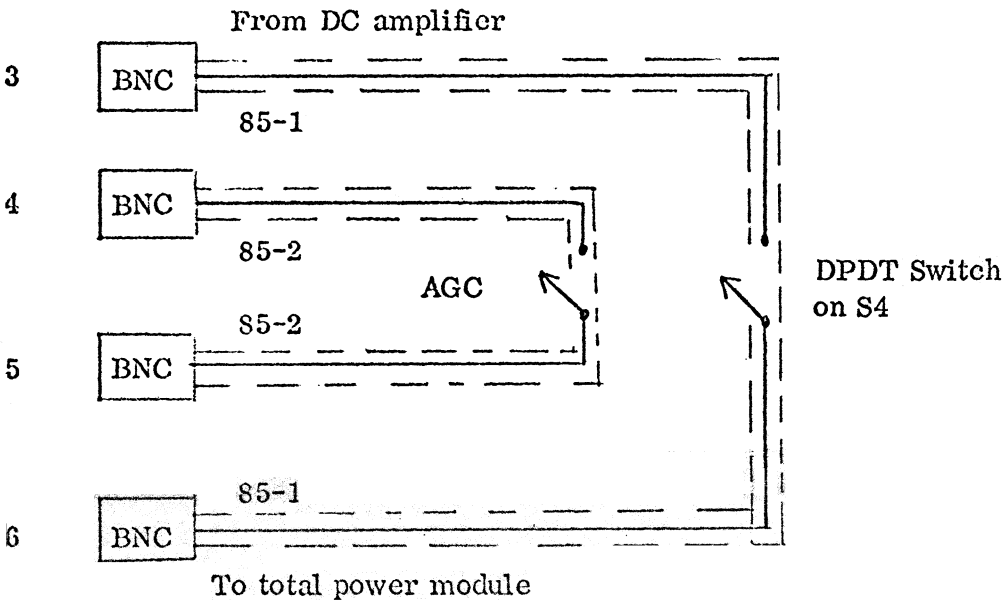
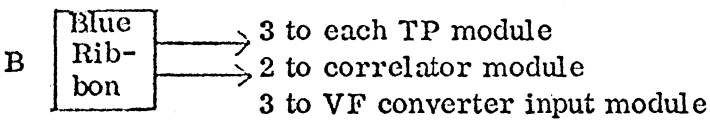
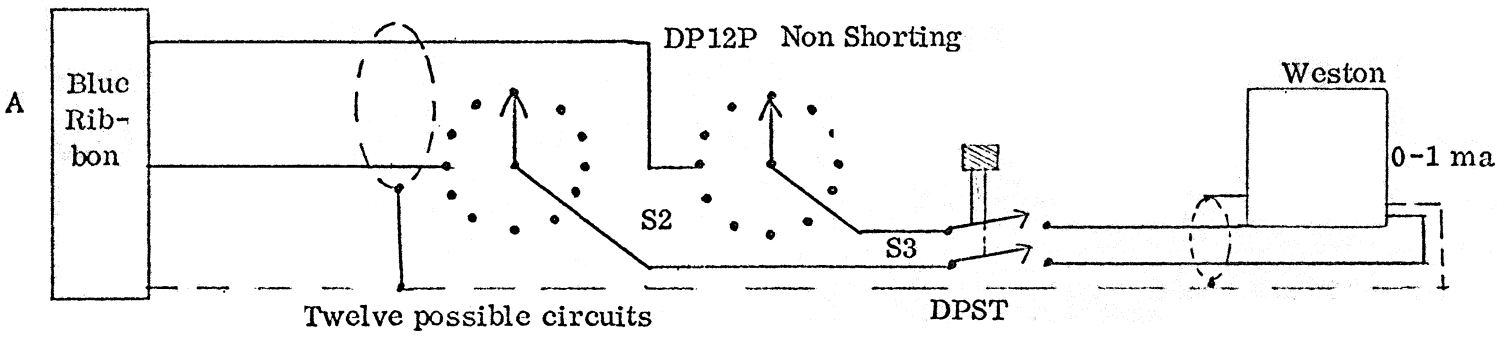
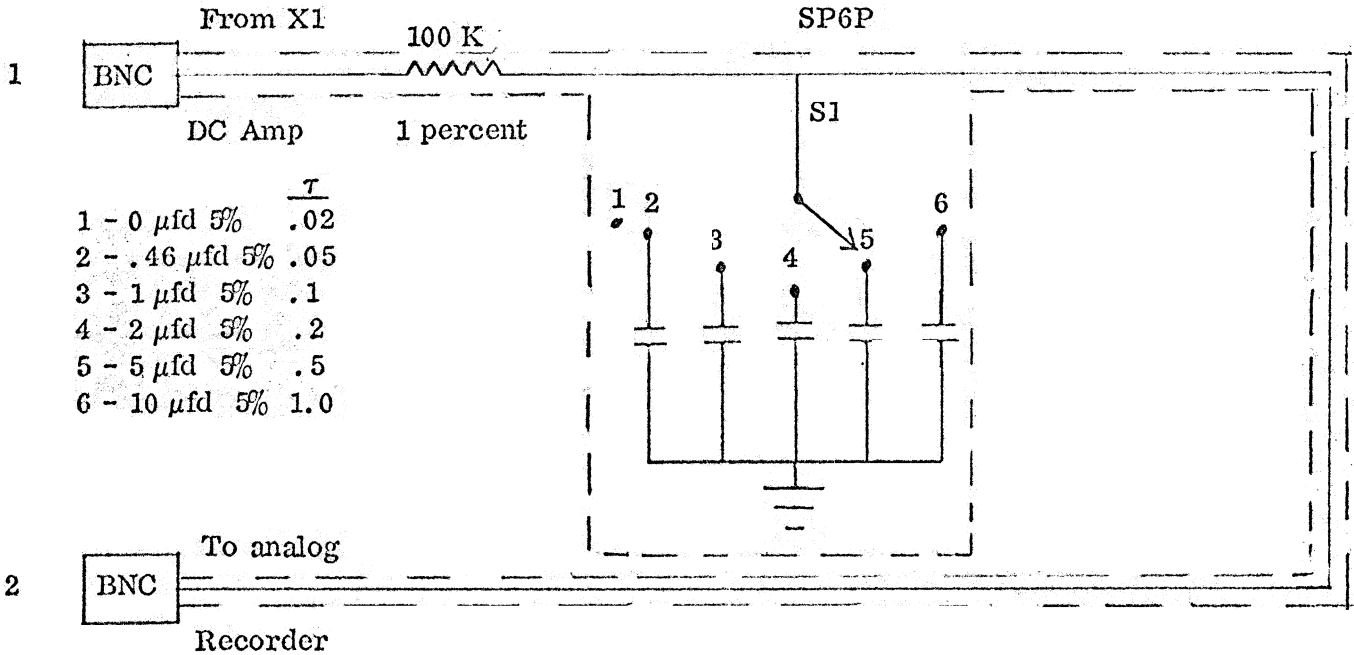
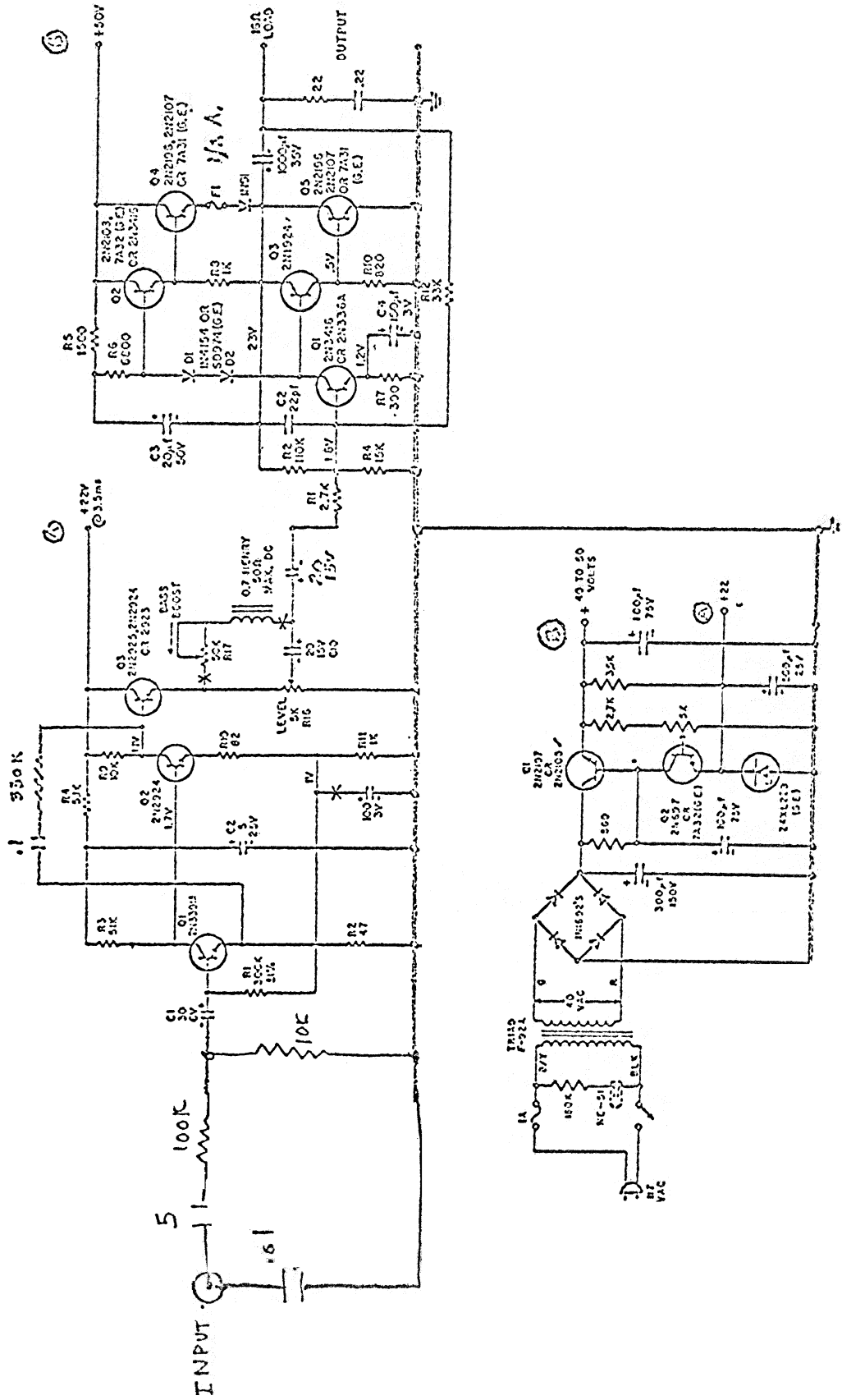
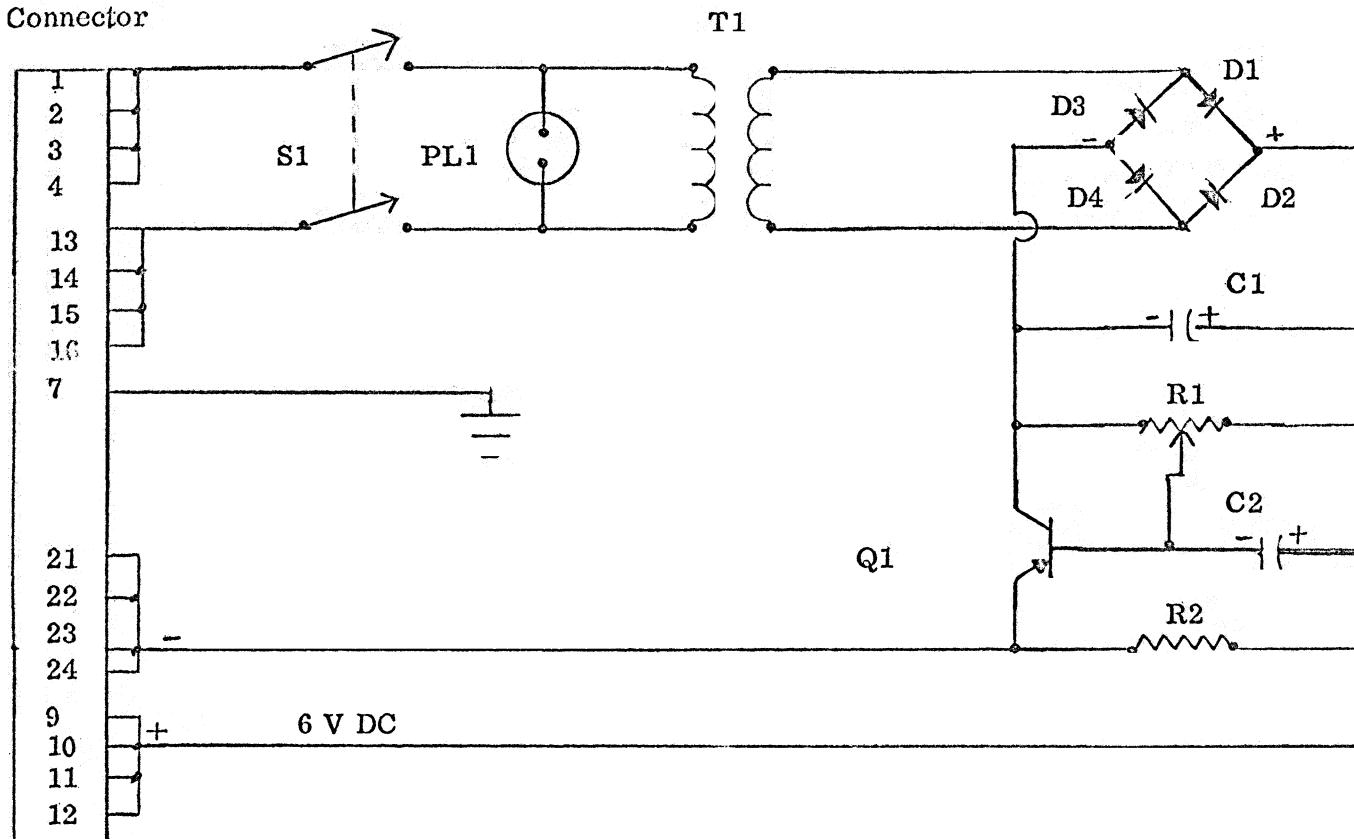

Figure 18. Monitor Module

Figure 19. Audio Amplifier Schematic



Blue Ribbon
Connector



- T1 Knight Filament Transformer - 7.5 V AC 4A
 PL1 Lee Craft Tineon No. 3600 ÷ 125,V, 1/3 watt
 S1 Microswitch No. 6AT3, DPDT
 Q1 GE-3 AF Power Transistor
 D1,2,3,4 GE No. A10A Silicon Rectifier Cell
 C1 1000 μ fd -- 15 V DC
 C2 500 μ fd -- 15 V DC
 R1 500 ohm adjustable
 R2 470 ohm

Figure 20. Meter Power Supply

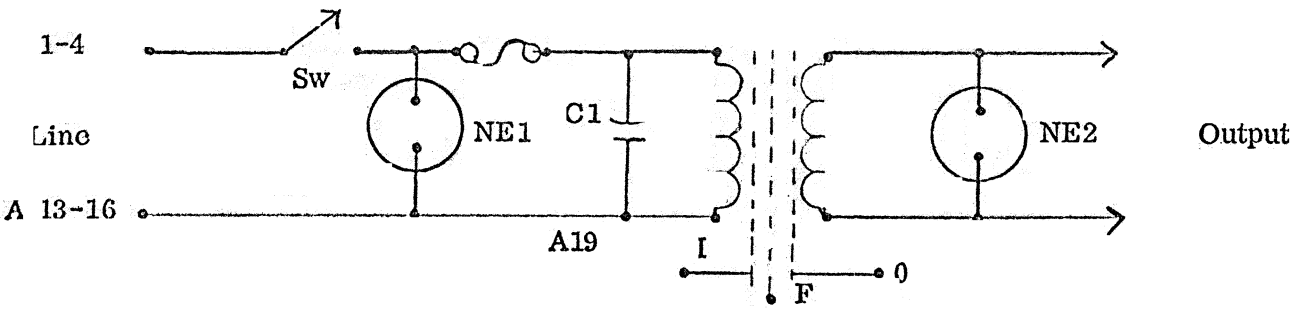

- Fuse - 1 amp SB - Hit 1
- Fuse - 1.75 amp SB - Hit 15
- Fuse - 5 amps - Hit 3

NE1, NE2 - Tineon Neon Indicator
 Sw - 5 amp, 120 V
 C1 - 0.1 μ fd. 600 V

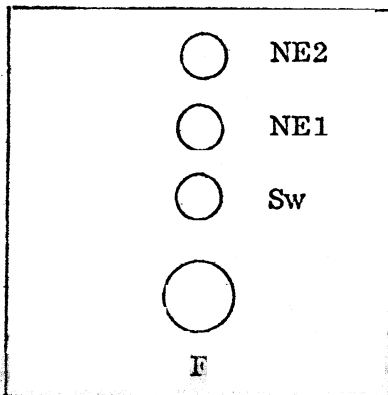

Hit 3

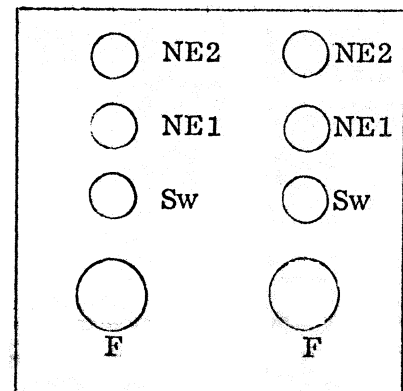

Hit 1 and Hit 15

Figure 21. Isolation Transformer Module