

NATIONAL RADIO ASTRONOMY OBSERVATORY

Green Bank, West Virginia

ELECTRONICS DIVISION INTERNAL REPORT NO. 298

GBT WEATHER STATION

David Seaman

March 1995

The Green Bank Telescope (GBT), like all other NRAO telescopes, requires accurate weather information. This information is used for protection of the antenna structure from dangerously high loads from wind, and to correct for pointing errors caused by atmospheric refraction; see GBT Memo 112 by Ron Maddalena. Due to size of the GBT structure, and the influential effect of the surrounding topography on the semi-local wind, it is desired to have two weather stations. One station, consisting of wind speed and direction, temperature, and barometric pressure, is located on an existing 150' tower opposite the Interferometer Control Building (ICB). This tower is approximately 1800' SW of the GBT. The second tower is located approximately 500' away from the GBT and 35° West of North. This location was selected to keep the tower at the most northerly location possible to reduce interference. The slope of the ground into the ditch, and the GBT power line, prohibited a further north placement. The second tower will have wind speed, direction, and temperature sensors.

At the base of both towers is an electronics enclosure. The vendor supplied electronics for the wind and temperature sensors are located here. NRAO added a VLBA MCB standard interface board to digitize the 0-5 VDC analog outputs. The data is then carried by fiber to a local network connection (see attached schematic). Fiber was chosen as the carrier to eliminate the possibility of lightning entering the control building via the wire, and to eliminate the losses associated with copper. From the base of the tower, the first station is connected to a VME crate in the ICB basement. The second tower will be connected to a similar computer in the local GBT control building. Located inside one of these two buildings is a chilled-mirror dew-point monitor. An internal device, which draws in outside air through a tube, was selected to reduce electronic drift due to changing atmospheric temperature-calibrations. The following is a brief description of the instruments selected.

Wind Speed
manufacturer
description

Met One Instruments, Model TG1564B, Model 170-41 cup assy.

The wind speed sensor is a light chopping device which outputs a variable frequency square wave, with frequency linearly proportion to shaft speed. This unit has an accuracy of +/- 0.15 mph, or 1%, whichever is greater. The starting threshold is 0.6 mph with the standard three-cup assembly. A six-cup assembly is also available, which reduces the threshold to 0.5 mph.

Wind Direction
manufacturer
description

Met One Instruments, Model TG1565C, Model 53.1 vane assy.

The wind direction sensor incorporates a high resolution resolver which forms the measuring circuit. This resolver is a non-contact device which reduces wear-out problems associated with potentiometer driven units. The resolver outputs a dual sine wave; the phase difference between the two gives the wind direction. This unit is accurate to +/-2°.

Temperature Sensor
manufacturer
description

Met One Instruments, Model T200, Model 5980 Radiation Shield.

The temperature sensor is a platinum RTD, with a calibrated accuracy of +/- 0.10°C. The sensor is mounted in a wind-aspirated radiation shield.

Dew Point Sensor

manufacturer
description

General Eastern Instruments, Model D2, Model M1 Controller.

This unit is a modular-chilled mirror system which has a total system accuracy of $\pm 0.2^{\circ}\text{C}$. The advantage to a modular unit is the ability of having the controller and mirror assembly in an environmentally controlled location. This will reduce electronic drift with temperature and should increase the reliability of the system. Air is drawn through the unit via a 1/4 tube connected to a vacuum pump. The pump operates at 2scfh. The outputs of the controller are via a RS232 port, or a 0-5VDC analog signal.

Barometric Pressure

manufacturer
description

Setra, Model 270, with #707 option.

This unit has a ceramic capsule which deforms under pressure, which changes the electrical capacitance. Accuracy is $\pm 0.03\%$ of the full scale 1100 mbar, or 0.33 mbar. It will be located in one of the electronics' enclosures, with a hose running to the outside.

The selection of the various components was mainly dictated by the accuracy requirements of GBT Memo 112. The wind direction sensor selection was partially based on information collected at the VLA/VLBA. They had experienced potentiometer wear out on contact-type direction vanes. The wind speed sensor accuracy dictated using the optical pulse counter rather than a DC voltage generator. The DC generators also required calibrations to be done based on the amount of wire connected to them, thus, not being interchangeable without re-calibration. The pulse counters selected are interchangeable and require only initial factory calibration. For operational safety, when operating under emergency power, a DC voltage-generating wind speed sensor will be located in the local control building.

Also attached are calibrated certificates from the manufacturers, and various sketches showing the layout of the system. Complete manuals are available in the Green Bank Electronics Department.

500' BUILDING

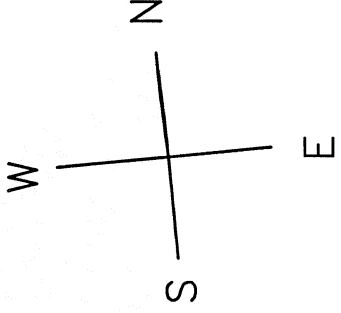

EXISTING TOWER

INTERFEROMETER CONTROL BUILDING

1780'

500'

NEW TOWER

GBT

140' TELESCOPE

ELECTRIC HUT

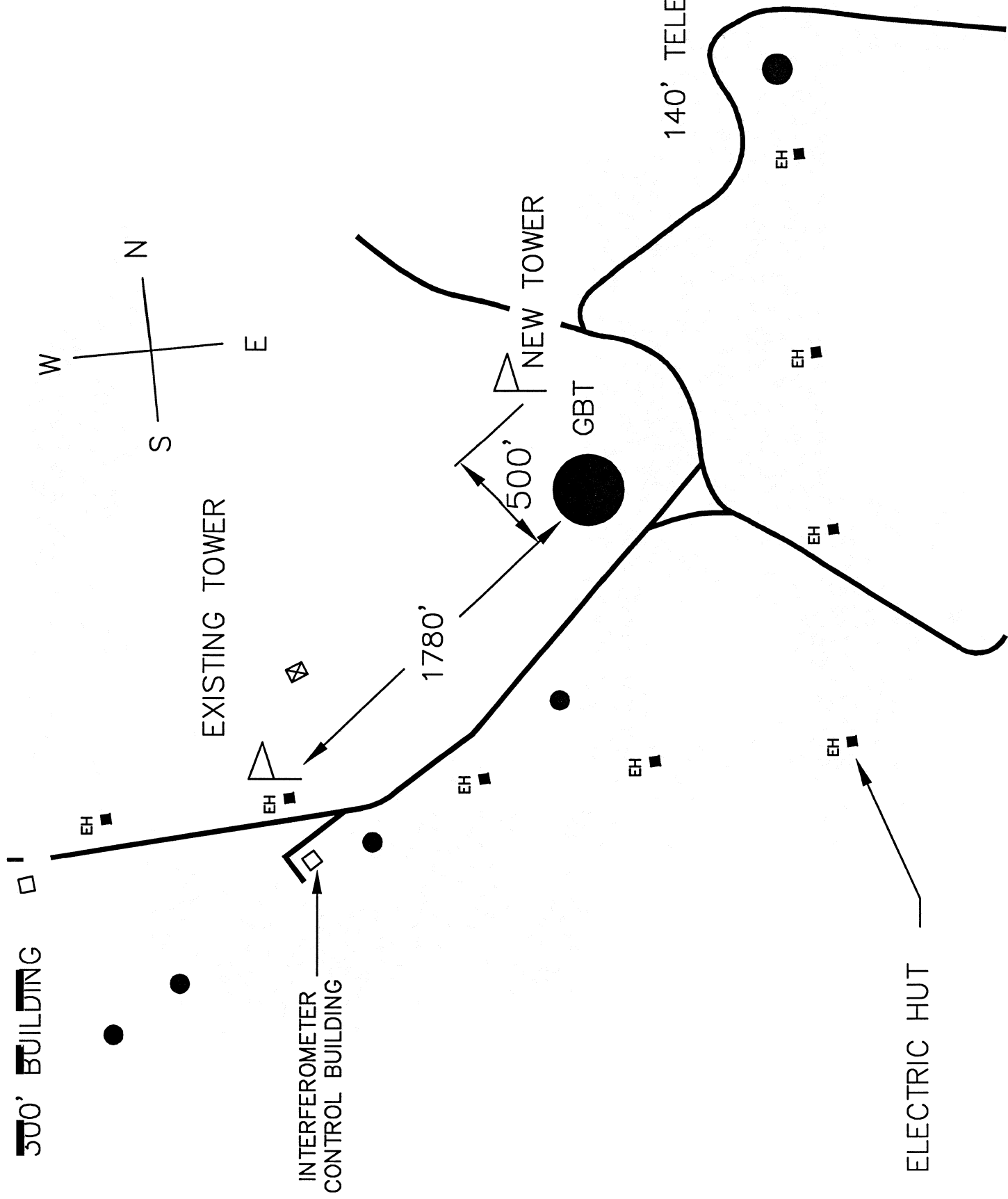

WEATHER1.DWG
JAN 94
REVISED NOV 94

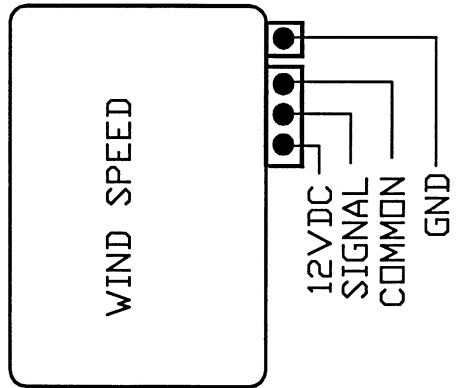
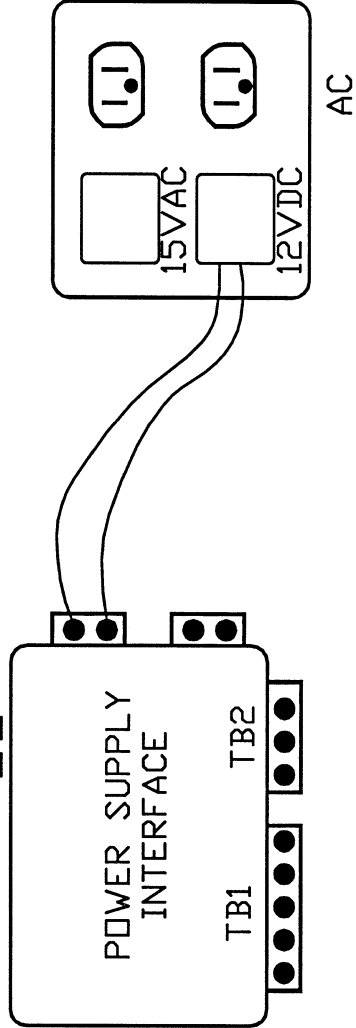
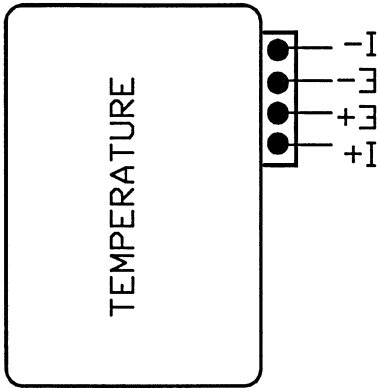
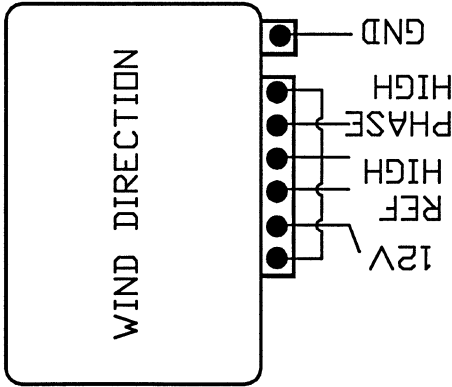
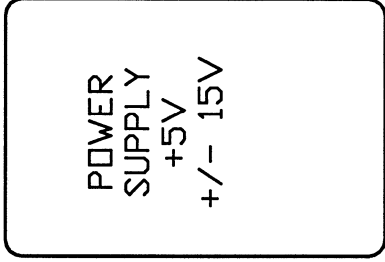
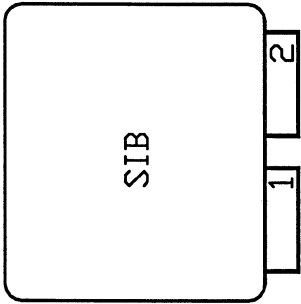
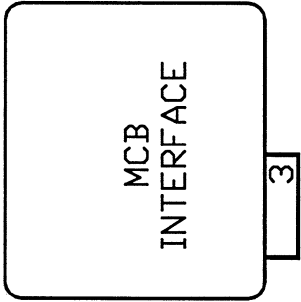
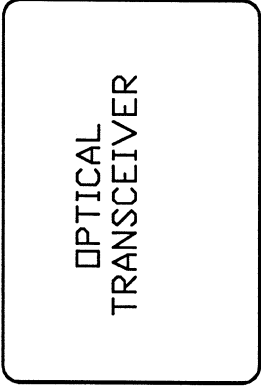

WEATHER STATION ELECTRONICS ENCLOSURE LAYOUT

Parallel I/O - P1

Type: Cinch or Amphenol DD-50PC

Mating Type: DD-50S

Pin	Signal	
01	ANLG-0H	TB2-1
02	ANLG-1H	TB2-2
03	ANLG-2H	TB2-3
04	ANLG-3H	GND
05	ANLG-4H	PS-GRN
06	ANLG-5H	GND
07	ANLG-6H	GND
08	ANLG-7H	GND
09	CON/MON-15	NC
10	CON/MON-13	NC
11	CON/MON-11	NC
12	CON/MON-09	NC
13	CON/MON-07	J3-9
14	CON/MON-05	J3-11
15	CON/MON-03	J3-13
16	CON/MON-01	J3-15
17	HI/LO SEL	J3-D
18	ANLG-0L	TB1-1
19	ANLG-1L	TB1-2
20	ANLG-2L	TB1-3
21	ANLG-3L	GND
22	ANLG-4L	PS-WHT
23	ANLG-5L	GND
24	ANLG-6L	GND
25	ANLG-7L	GND
26	CON/MON-14	NC
27	CON/MON-12	NC
28	CON/MON-10	NC
29	CON/MON-08	NC
30	CON/MON-06	J3-10
31	CON/MON-04	J3-12
32	CON/MON-02	J3-14
33	CON/MON-00	J3-16
34	5V COMM	
35	DEV REQ	J3-X
36	DEV ACK	J3-E
37	ANENB	J3-3
38	HIQ GND	GND
39	-15V	
40	+15V	
41	RA-7	J3-W
42	RA-6	J3-V
43	RA-5	J3-U
44	RA-4	J3-T
45	RA-3	J3-S
46	RA-2	NC
47	RA-1	NC
48	RA-0	NC
49	R/-W	J3-C
50	+5V	

Serial I/O - P2

Type: Cinch or Amphenol DB-25PC

Mating Type: DB-25S

Pin	Signal	
01	+5V	
02	(reserved)	
03	(reserved)	
04	(reserved)	
05	(reserved)	
06	(reserved)	
07	(reserved)	
08	(reserved)	
09	ID REQ	J3-K
10	D OUT	NC
11	PARX	NC
12	MSG	NC
13	5V COMM	
14	+5V	
15	+15V	
16	-15V	
17	HIQ GND	GND
18	XA CT	
19	RCV+	OT-1
20	RCV-	OT-2
21	XMT+	OT-3
22	XMT-	OT-4
23	(reserved)	
24	BUSY	NC
25	5V COMM	

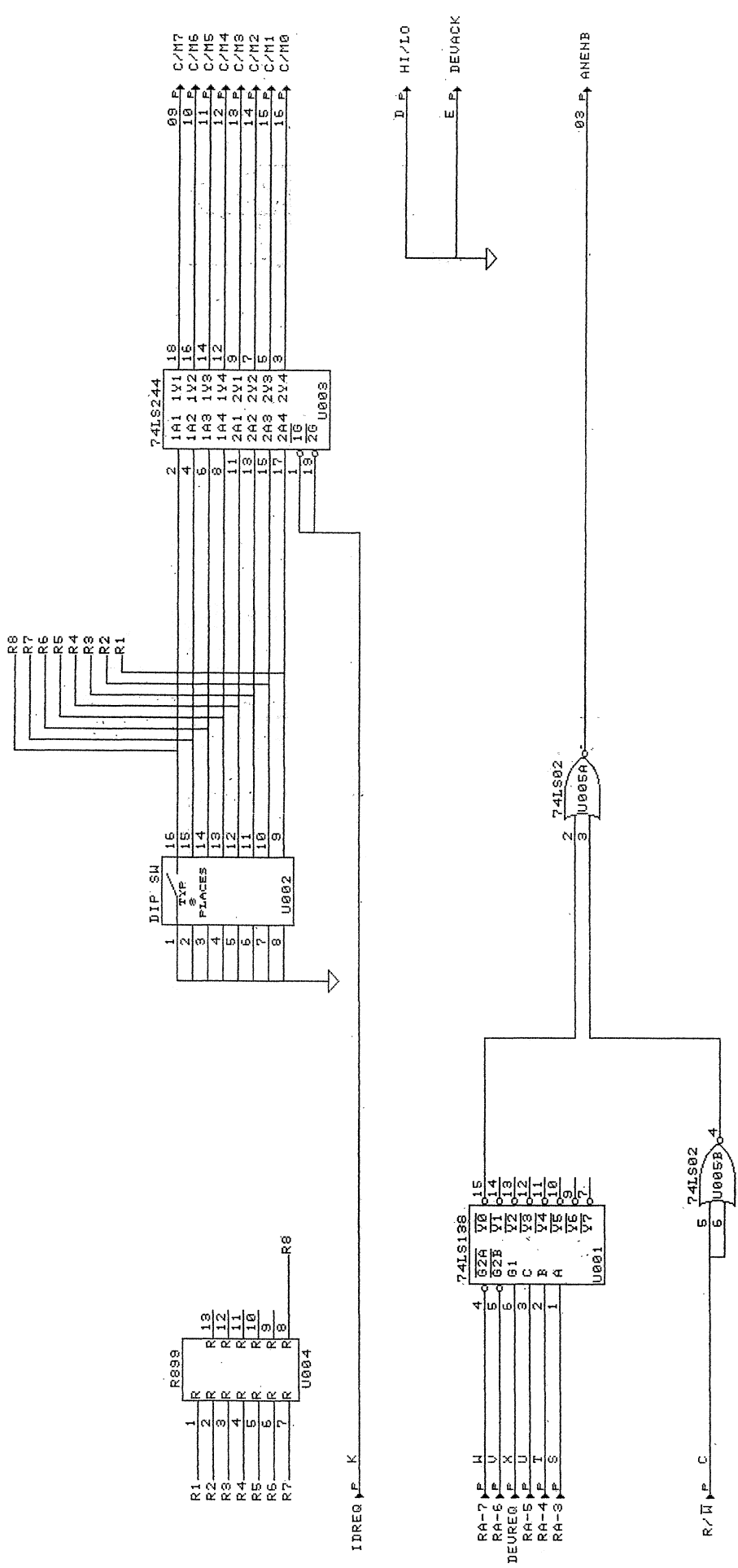

GROUND PINS 1,A,22,&2
+SVOITS PINS 2,B,21,&Y

NRAO GREEN BANK	
TITLE MONITOR AND CONTROL BUS WEATHER STATION INTERFACE	
SIZE B	REV A
NUMBER XXXXXX	SHEET 1 OF 1
DATE OCT 3, 1994	

1564B WIND SPEED

1565C WIND DIRECTION

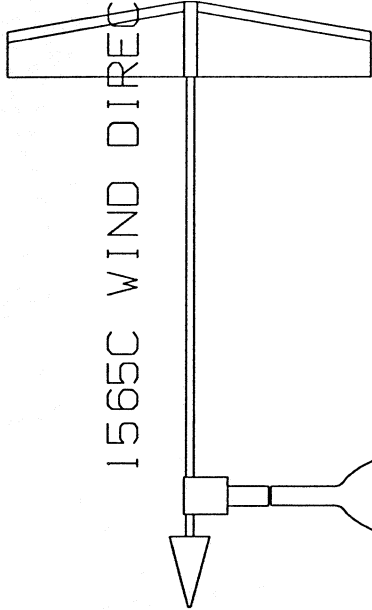
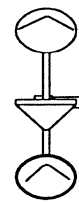

TEMP SHIELD
MODEL 5980

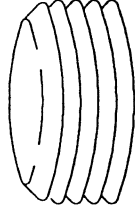

T200 TEMP PROBE

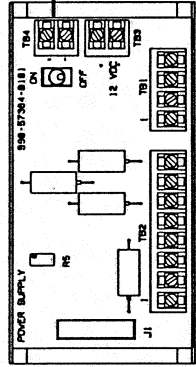
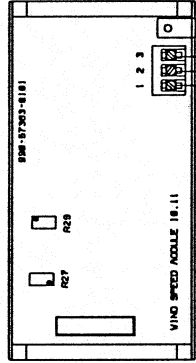
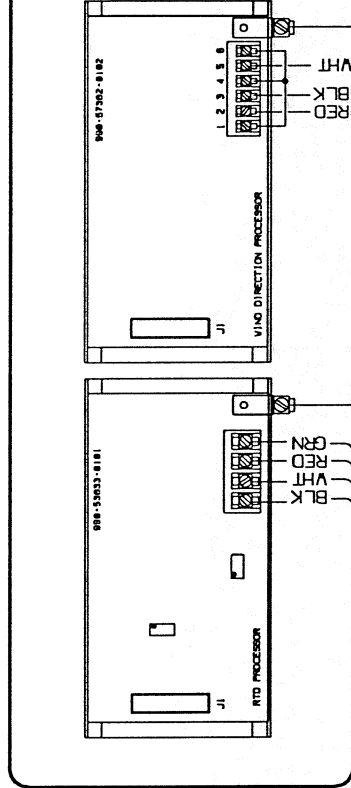
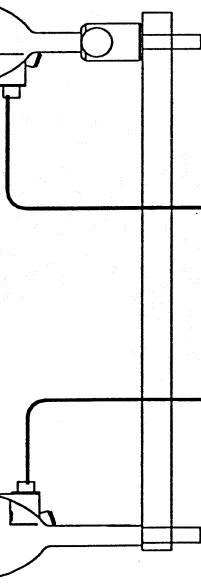

CABLE #45176

CABLE #45175

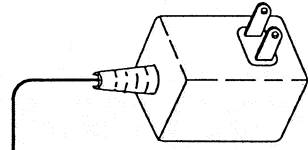

PS10

outputs
0-5 volts

COMMON

MET ONE INSTRUMENTS, INC.
GRANTS PASS, OREGON 97526

SCALE: _____ DRAWN BY: _____
DATE: _____ REVISED: _____

APPROVED BY: *R. B. ...*

Wiring Diagram

DRAWING NUMBER
NRAD-3

SHOWN WITH DOOR REMOVED

CUSTOMER AREA
14 X 16 X 8.5 INCH

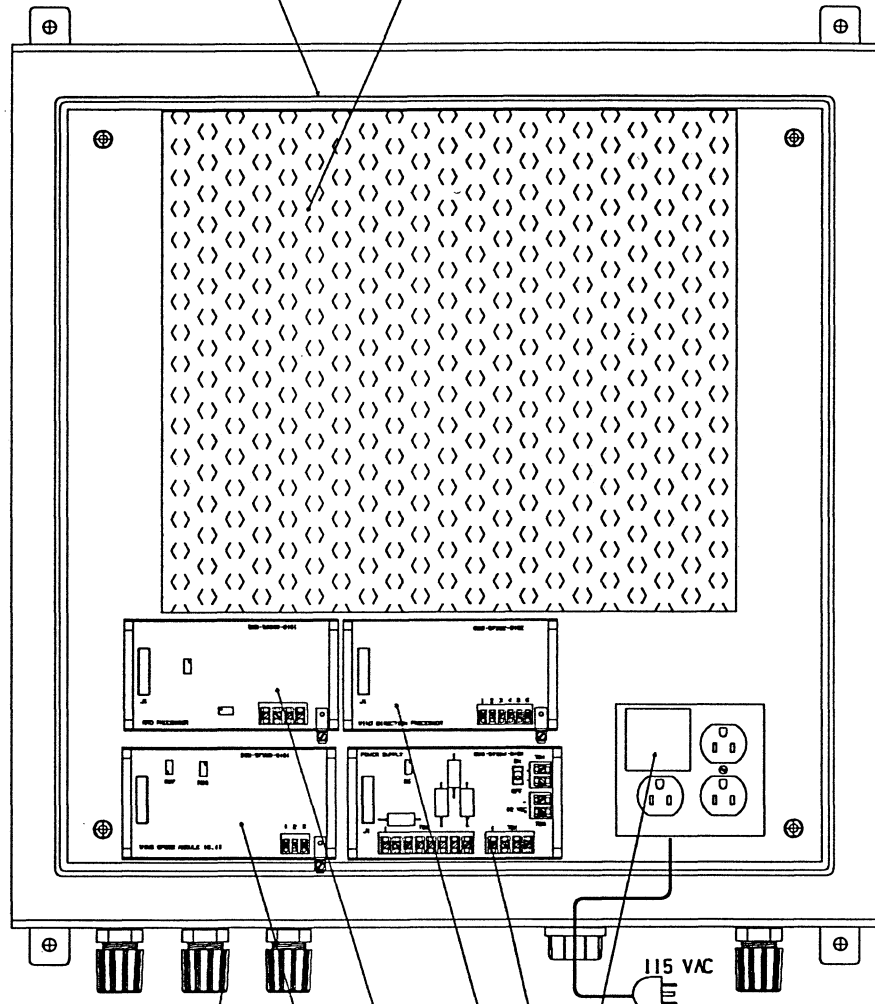

CABLE ENTRANCE

PS-10 POWER ADAPTOR

18.11 POWER SUPPLY

10.21 WIND SPEED

10.32 TEMPERATURE

10.11 WIND SPEED

MET ONE INSTRUMENTS, INC.	
ORANT'S PASS, OREGON 97126	
SCALE:	APPROVED BY:
DATE:	REVISION:
Box Internal Layout	
DRAWING NUMBER	
MPAO-2	



Calibration Certificate

TECHNICIAN: _____ S/N: 434767 MODEL: 270
 PART NO.: 270100-SP PROD. ORDER: R35887 RANGE: 800 TO 1100 MBAR
 SPEC. FILE: 270100.SP LOC.: 3A-61 NOM. OUT: 0 TO 5 VDC
 TRANSFER STD.: DATE: 3-3-95 EXCIT: 12 VDC

CALIBRATION DATA

(TEMP. 70.0°F +/- 0.5°F)

APPLIED PRESSURE (MBAR)	TRANSDUCER OUTPUT (VDC)	NONLINEARITY (% FS)	EXTRAPOLATED ERRORS (% FS)
800	+00.0004	00.000	ZERO: 00.008
900	+01.6670	-00.007	
1000	+03.3333	-00.020	
1100	+05.0012	00.000	FS OUT: 00.016

SPECIFICATIONS:

- Nonlinearity: +/- 0.03% FS, END POINT method, ISA.#5-37.1
- Zero pressure output: 0 VDC +/- 0.1 % FS
- Full-Scale output: 5 VDC +/- 0.1 % FS

NOTES:

- All errors are expressed as: Percent Full-Scale output.
- Consult specification sheet for additional specifications.
- This calibration is certified per N.I.S.T. traceable primary standards.
 Primary std.: P2-906/C2-1567, NIST# TN-249770-92, Cal. date: 02-01-95

OPTIONS:

- 1) REPLACED SENSOR COMPLETE RECAL

45 Nagog Park, Acton, MA 01720/Telephone 1-800-257-3872, In MA (508) 263-1400

GENERAL EASTERN INSTRUMENTS

The Humidity Experts

CERTIFICATE OF CONFORMANCE

CALIBRATION PERFORMED IN ACCORDANCE WITH MIL-STD 45662A

REPORT OF CALIBRATION/SYSTEM UNDER TEST

MODEL: M1/D-2	S/N: 0460794
---------------	--------------

NOTE: NIST has a Maximum Uncertainty of ± 0.04 °C from 25 to -35°C and ± 0.1 °C for Frost Points from -35 to -70°C. GEI's Transfer Standard and Manufacturing Standard are Compensated to This Uncertainty Band.

1.	GEI TRANSFER STD DEW POINT/RH	CUSTOMER DEW POINT/RH	DIFFERENCE	SPECIFICATION OF UNIT
	-23.41°C	-23.4°C	-0.01°C	± 0.20 °C
2.	-9.92°C	-10.0°C	0.08°C	± 0.20 °C
3.	0.05°C	0.0°C	0.05°C	± 0.20 °C
4.	9.26°C	9.2°C	0.06°C	± 0.20 °C
5.	21.80°C	21.7°C	0.10°C	± 0.20 °C

1.	GEI AIR TEMP. STD	CUSTOMER AIR TEMP. POINT	DIFFERENCE	SPECIFICATION OF UNIT
2.				

GENERAL EASTERN INSTRUMENTS MEASUREMENT STANDARD

DEW POINT		AIR TEMPERATURE	
MODEL: M-3	S/N: 1990693	MODEL: A1011-XX-XX-RT41-RT41	S/N: T1189-9142
SENSOR: 1311DR	S/N: 1990693	PROBE: A12001	S/N: 308458
CURRENT NIST I.D. #: H-4475		CURRENT INSTRUMENT NIST TEST #: 811/249718	
CURRENT NIST TEST #: 252396		CURRENT PROBE NIST TEST #: 222173/242309/2477770	
CALIBRATION DATE: 7-16-1993		CALIBRATION DATE: 10-27-1993	
DVM MODEL: Data Precision 2590	S/N: 2021	CALIBRATION DATE: 10-19-1993	
CURRENT NIST TEST NO.: 246764			
GENERAL EASTERN INSTRUMENT CALIBRATION PROCEDURE: A40076309			

RECOMMENDED CALIBRATION INTERVAL: 1 YEAR
FORM#: A40103046E

TESTED BY: P. S. Bani
APPROVED BY: N. Park
DATE: July 15, 1994

GENERAL EASTERN INSTRUMENTS
20 COMMERCE WAY, WOBURN, MA 01801 Tel.: (617) 938-7070 FAX: (617) 938-1071