

NATIONAL RADIO ASTRONOMY OBSERVATORY

Green Bank, West Virginia

Electronics Division Internal Report No. 283

A S/X, FOUR CHANNEL, CRYOGENIC DEWAR PACKAGE

Roger D. Norrod

April 1989

Number of Copies: 150

A S/X, FOUR CHANNEL, CRYOGENIC DEWAR PACKAGE

Roger D. Norrod

TABLE OF CONTENTS

	<u>Page</u>
1.0 Introduction	1
2.0 Dewar Package Design	1
2.1 Vacuum Chamber	2
2.2 Refrigeration	3
2.3 Waveguide Input Transitions	5
2.4 Microwave Components	8
2.5 Dewar Wiring	9
3.0 Dewar Cardcage Design	10
3.1 Monitor Card	13
3.2 Bias Card	14
3.3 Sensor Card	14
4.0 Performance	15
4.1 S-Band Performance	15
4.2 X-Band Performance	16
4.3 Refrigeration Performance	16
5.0 Acknowledgements	17

Continued --

LIST OF TABLES

Table 1	15 Kelvin Heat Loads	5
Table 2	Cardcage Power/Monitor Connections	12
Table 3	Modifications to Sensor Card Resistor Values	14

LIST OF FIGURES

Figure 1	Photograph of S/X Dewar Assembly	F-1
Figure 2	Dewar Interface	F-2
Figure 3	Dewar Interior	F-3
Figure 4	S-Band Transition Details	F-4
Figure 5	X-Band Transition Details	F-5
Figure 6	X-Band Waveguide Interface	F-6
Figure 7	Dewar Wiring	F-7
Figure 8	Dewar Cardcage	F-8
Figure 9	Vacuum Sensor Circuit Output Voltage vs. Pressure	F-9
Figure 10	Modification to Monitor Card for S/X Cardcage	F-10

APPENDICES

Appendix A	Bills of Material and Wiring List	19
Appendix B	Dewar Test Data	20
Appendix C	Component Manufacturers' Data Sheets	21
Appendix D	Sensor Card Calibration	22

A S/X, FOUR CHANNEL, CRYOGENIC DEWAR PACKAGE

Roger D. Norrod

1.0 Introduction

This report describes the design, construction, and testing of a four channel, dual-frequency, cryogenic dewar package used in a dual-polarized S/X receiver. The package consists of a vacuum chamber with waveguide input ports, two 2.0-2.5 GHz HEMT amplifiers, two 8.0-8.8 GHz HEMT amplifiers, a closed-cycle refrigerator, and an electronics cardcage that provides bias voltages for the cooled amplifiers and temperature and vacuum monitor circuits.

In conjunction with the development of the cryogenic dewar package, a dual-polarized feed was developed, and these, with other circuitry, were incorporated into a prime-focus front-end box. That work was done by other members of the staff, and this report will be confined to the dewar package and associated cardcage. The 8.0-8.8 GHz amplifiers are described in Electronics Division Internal Report No. 254, and the 2.0-2.5 GHz amplifiers will be described in a future report.

2.0 Dewar Package Design

Figure 1 is a photograph of a completed dewar package. The vacuum chamber is formed from a housing machined from aluminum, and two one-half inch thick aluminum plates. The dewar has three waveguide inputs: two S-Band rectangular waveguides, and a X-band circular waveguide. (A polarizer is within the dewar to obtain the two opposing circular polarizations from this single waveguide input). Hermetic DC Feedthru assemblies are used to pass amplifier bias voltages, heater voltages, and temperature sensor connections into the dewar. Eight SMA hermetic connectors are used for outputs from the four cooled

amplifiers and inputs to a calibration injection coupler in each channel. A multipin DC connector is provided to which a cable from the dewar cardage is connected. A manual vacuum valve and a thermocouple vacuum sensor are mounted on the dewar.

Figure 2 shows the overall dimensions of the dewar package. The completed assembly weighs 88 pounds; 22 pounds is due to the refrigerator. A Bill of Materials for the dewar assembly is included in Appendix A, listing all the components' part numbers and manufacturers. A discussion of the major components follows. NRAO drawing numbers are given in parentheses following the first mention of major fabricated parts.

2.1 Vacuum Chamber

The dewar body (D17211M011) is machined from a solid block of aluminum (alloy 6061-T6), approximately 15 x 15 x 6 inches. The center is first rough-sawn out, and then the walls are finish machined to the proper thickness. The feed plate (D17211M010) and cover plate (D17211M012) are machined from one-half inch aluminum plate stock.

O-rings are used at all bolted joints in the dewar assembly. The compound specified when purchasing the o-rings is N674-70, recommended by the manufacturer for high vacuum applications. The o-rings are lubricated with a small amount of Apiezon Type L vacuum grease during assembly.

The vacuum valve, vacuum sensor, and refrigerator are attached to one side of the dewar body. A brass fitting (B17211M013) is silver-brazed into the commercial vacuum valve. This fitting accepts a o-ring and allows the valve to be bolted to the dewar body. A 2 1/2 inch length, 3/4 inch O.D. stainless steel tube is silver-brazed into the other valve port for acceptance of a vacuum pump

hose. Care should be taken when brazing the valve fittings to orient the valve properly. The brass o-ring fitting should be in the lower valve port (viewed with the valve knob at the top) so that the valve shaft bellows is not subjected to the dewar vacuum when the valve is closed.

The vacuum sensor is a Teledyne-Hastings DV-6 type thermocouple tube, and is threaded into a 1/4 NPT hole in the dewar body. A small amount of pipe thread sealant (e.g., Cajon SWAK p/n MS-PTS-50) is used on the DV-6 threads.

All of the remaining inputs and outputs are through the feed plate, and the waveguide transitions are supported off this plate. Access to the internal components is obtained by removing the cover plate and the radiation Shield 3 (D17211M023). Figure 3 shows the dewar interior.

2.2 Refrigeration

The closed-cycle refrigerator used is a CTI Model 350. This two-stage unit has approximately three watts of cooling capacity at the 15 Kelvin stage. The four amplifiers and the X-band polarizer are connected to the refrigerator second, 15 Kelvin stage, and the S-band waveguide transitions and the radiation shields are connected to the refrigerator first, 70 Kelvin stage.

The 70K Strap (B17211M027) is bolted to the refrigerator first stage and to a point where Shield 1 (D17211M021) attaches to one of the S-band waveguide transitions. Shield 1 acts both as a radiation shield and the conduction path through which both S-band transitions are cooled to approximately 60 Kelvin. Shield 2 (D17211M022) bolts to Shield 1, and Shield 3 bolts to Shield 2. Shield 4 (C17211M024) bolts to the underside of Shield 1 (viewed through the dewar cover plate opening), and extends into the X-band Cylinder (D17211M015) as a radiation shield for the X-band polarizer.

The S-band amplifiers and the X-band amplifiers, couplers, and isolators are mounted on the 15K Plate (D17211M026), which attaches to the refrigerator second stage. The 15K Plate is bent from a single sheet of OFHC copper. Temperature measurements made near the refrigerator attachment point and on one of the X-band amplifiers showed less than a 2 Kelvin temperature drop along the length of the 15K Plate. The 15K sensor is normally mounted near the S-Band amplifiers and typically indicates 14.5 Kelvin.

Activated charcoal pellets (Wilco Chemical AC-4051) are attached to the 15K Plate with flexible epoxy (Armstrong A-12). The charcoal increases the cryo-pumping capacity of the refrigerator and decreases the cool-down time by improving the vacuum within the dewar. Six to nine square inches of the 15K Plate is covered with the charcoal pellets.

To achieve optimum cooling, the 70K Strap and the 15K Plate should be annealed after bending by heating until red-hot and then cooling slowly. Indium shims, 5 mils thick and 99.999% pure, are used under all bolted joints where good temperature conduction is required.

Two 50 watt, 120 V resistive heaters are mounted in the dewar, one on the 15K Plate and one on Shield 1. A safety thermostat (open on rise at 140 degrees F) is mounted near each heater and wired in series. The two heater/thermostats are wired in parallel at the dewar DC connector, and the parallel heater resistance is approximately 145 ohms.

Estimates of the electrical and conductive thermal loading on the refrigerator 15 Kelvin stage are given in Table 1.

TABLE 1
15 Kelvin Heat Loads

Item	Heat Load (mW)
Amplifier Bias (5 V x 15 mA x 12 stages)	900
LED Bias (2 V x 10 mA x 4 LED)	80
X-Band Transition Supports	120
Coaxial In/Out Lines	300
32 AWG Brass Wires (28 bias wires)	32
36 AWG Copper Wires (2 Sensor wires)	9
32 AWG Copper Wires (2 Heater wires)	24
TOTAL	1,465

The cooldown and warm-up characteristics of the dewar package are discussed in Section 4.

2.3 Waveguide Input Transitions

The details of the S-band transition assembly is shown in Figure 4. The waveguide assembly (C17211M005) consists of two standard UG-437 waveguide flanges and a length of WR-430 waveguide. An o-ring groove is machined in the flange which bolts to the Feed Plate. Low-loss foam material (Emerson & Cuming PS-1.04) is epoxied into the waveguide, forming the vacuum window. At the feed end of the waveguide, the foam is covered with a film of Saran-Wrap to prevent moisture absorption by the foam.

The waveguide to coax transition is bolted to the Transition Plate (D17211M006), and is supported off the Feed Plate at six points by epoxy/fiberglass rods. The lengths of the rods are set so that a gap of 0.012 ± 0.002 inches exists between the Transition Plate and the Feed Plate. This waveguide gap provides thermal isolation between the Feed Plate at 300 Kelvin and the waveguide transition at 60 Kelvin. The heat loading through the series connection of a pair of Support 1 (B17211M009-01) and Support 2 (B17211M009-02) is calculated to be 60 mW. Therefore, each S-band transition assembly provides a conductive heat loading to the refrigerator 60K station of 360 mW.

After construction of the first, S/N 01, dewar, there was some concern that the S-band waveguide-to-coax transition probe was not being cooled properly and might be adding excessive noise. In the next two units, the transition probes were modified. The aluminum probe delivered by the transition manufacturer was removed and replaced by a copper probe. The coaxial connector was also replaced with a NRAO designed connector that incorporates a quartz support bead, providing good heat sinking of the center conductor to the connector body. As discussed in Section 4.1, it is not clear that these changes had a significant effect on the receiver noise temperature.

Detail of the X-band transition assembly is shown in Figure 5. The X-band vacuum window is formed by epoxying 0.014 inch thick mylar film into a recess in the Window Plate (D17211M016), followed by an aluminum matching iris. The epoxy is then cured while the assembly is clamped together. It is important to use an epoxy mix that remains slightly flexible to allow the window to deform under pressure, which distributes stresses over the window rather than concentrating them at the window edges. The flexibility of Armstrong A-12 epoxy can be controlled by adjusting the ratios of the resin and hardener components.

A 3/8 inch thick disk of low-loss foam (Emerson-Cuming PS-1.04) is pressed into the window plate on the vacuum side of the window to prevent radiation cooling of the mylar film, and problems with condensation.

The polarizer is a waveguide device with circular waveguide input, a transition to square waveguide, and a sloped-septum that separates left and right circular polarizations. Coaxial transitions are built into the polarizer. Electrical performance of the polarizer is given in NRAO specification A53200N001, Type D.

An alignment boss is machined on the polarizer waveguide flange, and the polarizer is bolted to the Polarizer Mount (D17211M014). The Polarizer Mount is supported off the Window Plate with four epoxy/fiberglass rods (B17211M009-03). The lengths of the rods are set so that a gap of 0.012 ± 0.002 inches exists between the Polarizer Mount and the Window Plate. This waveguide gap provides thermal isolation between the Window Plate at 300 Kelvin and the polarizer at 15 Kelvin. A choke groove is machined in the Polarizer Mount to reduce microwave radiation from the gap. The heat loading through each epoxy/fiberglass rod is calculated to be 30 mW. Therefore, the X-band transition assembly provides a conductive heat loading to the refrigerator 15K station of 120 mW.

The X-band Waveguide (B17211M017) provides connection to the feed X-band port, and is designed to use a quick-release coupling clamp (Leybold KF-50). An alignment boss is used at each X-band waveguide joint within the dewar assembly for accurate axial alignment of the circular waveguide. Figure 6 gives details of the X-band circular waveguide interface.

2.4 Microwave Components

The S-band amplifiers used have a HEMT in the first stage, followed by two GaAs FET stages. A LED is incorporated to illuminate the HEMT, required with most cooled HEMT's for optimum noise performance. The amplifier has approximately 32 dB gain and a noise temperature of 3 to 5 Kelvin when cooled to 15 Kelvin. The amplifier input circuit incorporates a 30 dB directional coupler which is used to inject calibration signals. Source-lead inductance is used to provide simultaneous noise and gain match; no input isolator is used. The amplifier will be described in detail in a future report.

The X-band amplifiers also are three stage units with a HEMT first stage. The amplifier was described in EDIR No. 254. (Actually an earlier, three-stage FET amplifier is described in that report, but the HEMT amplifier is very similar.) The amplifiers have approximately 34 dB of gain and a noise temperature of 7 to 9 Kelvin when cooled to 15 Kelvin. A commercial 30 dB stripline calibration coupler and ferrite isolator precede the amplifier; both are also cooled to 15 Kelvin.

A short length (3 to 4 inches) of standard 141 coaxial copper semi-rigid cable with stainless steel SMA connectors is used to connect the S-band waveguide transitions and X-band polarizer outputs to the amplifier inputs. Although the S-band transition is at 60 Kelvin, and the amplifiers are at 15 Kelvin, no special coax is used between the two. The stainless SMA connectors on the 141 cable provide adequate thermal isolation. At X-band, both the polarizer and the amplifiers are at 15 Kelvin. As a precaution to insure that these coaxial lines are well cooled, a copper strap is soldered to the outer jacket and then connected to the 15K Plate.

Coaxial cable with stainless steel, 0.087 inch O.D. outer jacket, and silver plated, beryllium-copper inner conductor is used for the amplifier output and calibration input connections to the Feed Plate. The thermal conductivity of these cables between 300 and 15 Kelvin is estimated to be 1475 mW-cm. The total heat load to the 15K station by all eight cables is estimated to be 300 mW. (Cables to the X-band components are approximately 24 inches long; cables to the S-band amplifiers are approximately 12 inches long.)

2.5 Dewar Wiring

An Elco 38-pin connector is provided for all DC connections to the dewar. Figure 7 shows the dewar wiring connections.

Two DC feedthru assemblies are mounted on the feed plate, and are used for all DC connections into the vacuum chamber. Twenty-two 1000 pF, 200 V and two 3000 pF, 500 V hermetic feedthru capacitors are soldered into each DC Feedthru Plate (A53206M008). The 500V feedthru capacitors are used for heater voltages; the others provide connections for amplifier bias voltages (six per amplifier), LED bias (one per amplifier pair), and temperature sensors (two per sensor). A silkscreened fiberglass disk is used to label the feedthru pins.

One feedthru pin is used to supply bias to two amplifier LED's. Two 300 ohm, 1/2 watt carbon resistors are used to split this voltage, and are epoxied on the vacuum side of the Feedthru Plate. A 510 ohm, 1/2 watt resistor, located in the dewar cardcage and connected to +15 volts, is connected in series with the supply side of these 300 ohm resistors. This arrangement supplies each LED with approximately 10 mA at 2 V.

Wiring to the amplifier bias connectors uses 32AWG brass wires, insulated with polyurethane. This wire exhibits fairly low thermal conductivity (65 mW-

cm, 300-20 Kelvin), and high electrical conductivity (0.13 ohms/cm at 300 Kelvin) [refer to EDTN No. 104]. The heat loading of each of the S-band bias wires (17 inches long) to the 15 Kelvin station is approximately 1.5 mW. The heat loading of each of the X-band bias wires (31 inches long) to the 15 Kelvin station is approximately 0.8 mW. The temperature sensors are supplied with 36 inch, 36AWG solid copper wires, which are trimmed to approximately 18 inch lengths. The heat loading of each of the two wires to the sensor on the 15 Kelvin station is approximately 4.4 mW (200 mW-cm, 300-15 Kelvin). Wiring to the heaters uses 32AWG, stranded copper, teflon insulated wires. This is used rather than the brass wire because of increased current carrying capacity, and improved insulation integrity. The heat loading of each of the two 16 inch long wires to the 15 Kelvin station is 12 mW (500 mW-cm, 300-15 Kelvin).

3.0 Dewar Cardcage Design

The cardcage used with the dewar is 11 x 7 1/2 x 4 3/4 inches, and weighs approximately 7 pounds. The cardcage accepts six circuit cards: one Monitor Card (B17211A003), four FET Bias Cards (D53200A002), and one Sensor Card (D53200A003 modified). A photograph of the assembled cardcage is shown in Figure 8, and a Bill of Materials (A17211B001) is included in Appendix A.

The cardcage top plate has six connectors. Wiring lists for each are included in the cardcage wiring list (A17211W001) included in Appendix A. A functional description of each follows:

- J1 - Dewar Connections - This 38-pin Elco, protected pin connector, provides connections to the dewar.
- J2 - Power/Monitor - This 20-pin Elco, exposed pin connector, provides power inputs to the cardcage, and remote monitor outputs.

- J3 - Dewar Vacuum Sensor - This connector accepts a cable from the dewar DV-6 vacuum sensor, and provides sensor input connections to the Sensor Card dewar vacuum monitor circuit.
- J4 - Aux Vacuum Sensor - This connector is similar to J3 and provides sensor input connections to the Sensor Card pump (or Aux) vacuum monitor circuits.
- J5 - Heater Power - A standard 115 VAC receptacle providing connections to the dewar internal heaters.
- J6 - Aux Monitor - A 25-pin D-connector, wired in parallel with J2, providing redundant power/monitor connections.

A description of the input and output connections to J2 is given in Table 2.

The vacuum monitor voltage output is a non-linear function of the pressure. The curve is given in Figure 9.

TABLE 2

Cardcage Power/Monitor Connections

Pin	Function	Description
A, X	Gnd	Power Return
B, W	+15 V	+15 volts input at 350 mA
C, V	-15 V	-15 volts input at 230 mA
D	Aux Vac Mon	0-10 V output of AUX vacuum monitor
E	Dewar Vac Mon	0-10 V output of dewar vacuum monitor
F	15K Mon	10 mV/Kelvin output of 15K temp. monitor
H	50K Mon	10 mV/Kelvin output of 50K temp. monitor
J	S-L Gate Mon	± 15 V range. Average of S-band, LCP channel amplifier gate voltages. Normal value -0.5 to -2.0 volts. Value > 0 V likely indicates a open drain; value < -2 V likely indicates a shorted drain. Will vary slightly with amplifier temp., but any other change should be checked.
K	S-R Gate Mon	As above, for S-band, RCP channel.
L	X-L Gate Mon	As above, for X-band, LCP channel.
M	X-R Gate Mon	As above, for X-band, RCP channel.
N	S-LED Mon	0-15 V range. Voltage at LED input to dewar for S-band amplifier LED's. Normal value 4 to 6 volts. Will vary slightly with amplifier temp., but any other change likely means problem with one or both of the S-band LED's.
P	X-LED Mon	As above for X-band amplifiers.
U	Quality Gnd	Monitor return.

3.1 Monitor Card

The Monitor Card is based on the Monitor Card used in the VLBA project (assembly D53200A006). A Bill of Materials (A17211B003) for the card is included in Appendix A. A photograph of the Monitor Card mounted in the card-cage is shown in Figure 8(b).

A rotary switch and DVM mounted on the end plate of the card allow local monitoring of the monitor points described in Table 2. TIP jacks (GND and MON) allow monitoring of the monitor points with external instruments, such as an oscilloscope. The MON jack is connected to the monitor point indicated by the rotary switch. When the rotary switch is in the MON position, an input voltage to the MON jack is connected to the Monitor Card DVM (± 20 V full scale).

A minor modification to the PCB traces is required for this application in order to obtain the proper meter decimal point locations for all of the monitor voltages. This modification is described in Figure 10.

3.2 Bias Card

The amplifier Bias Card used is identical to the VLBA Bias Card (assembly D53200A002). This card provides bias voltages for an amplifier with up to four stages, and the gate voltage is servoed to maintain constant drain current. This card is more fully described in VLBA Technical Report No. 1.

3.3 Sensor Card

A slightly modified version of the VLBA Sensor Card (assembly D53200A003) is used, also described in VLBA Technical Report No. 1. The modification is required because the DT-500 temperature sensors used on the VLBA project are no longer available. The DT-471 sensors used in the S/X dewar have a different calibration curve, requiring a change in the gain slopes and offsets in the temperature monitor circuits. The value of eight resistors must be changed, and the old and new values are listed in Table 3. A description of a Sensor Card calibration box and calibration procedures are given in Appendix D.

TABLE 3

Modifications to Sensor Card Resistor Values

<u>Designation</u>	<u>Old Value</u>	<u>New Value</u>
R41, R62	787. K	619. K
R42, R63	90.9 K	61.8 K
R45, R66	73.2 K	19.1 K
R46, R67	294.0 K	162. K

4.0 Performance

To the date of this report, three of the S/X dewar packages have been built and tested. One unit (S/N 01) was placed on the Green Bank 85-3 telescope in January 1989. Repeated problems with the closed cycle refrigerator was experienced, and the entire dewar package was replaced with S/N 02 in March 1989. However, the refrigeration problems proved to be due to a contaminated helium supply line on the telescope. Once that problem was corrected, the system has provided reliable service.

Test data on the S/N 03 system is contained in Appendix B, and is summarized below.

4.1 S-Band Performance

The S-band channels provide minimum noise temperatures of 9 to 11 Kelvin, referenced to the room-temperature waveguide flange, and gain of typically 32 to 34 dB. The gain variation over the 2.0-2.5 GHz range is less than ± 1 dB. Gain from the cal input to the dewar output is 30 ± 1 dB below the waveguide input - dewar output gain. The input return loss is typically 10 to 15 dB; output return loss 15 to 20 dB; and cal return loss 10 to 15 dB.

The noise measurements show a peak at approximately 2.05 GHz. This is due to a resonance in the waveguide gap in the input thermal transition. The peak is outside the frequency range required for VLBI, the primary application of this receiver. To eliminate the peak would require redesign of the waveguide gap, and is not felt to be necessary at this time.

For the three dewars built so far, the difference between the measured dewar noise temperature (referenced to the room temperature input flange) and the measured amplifier noise temperature (referenced to the cold amplifier input

connector), averaged over 2.1 to 2.4 GHz, varies between 4.5 and 8.3 Kelvin. We routinely obtain a 3 to 4 Kelvin noise temperature difference in L-band receivers. The cause of this variation in the S-band data has not been determined. There was no clear improvement in this difference when the S-band waveguide-to-coax transitions were modified as described in section 2.3.

4.2 X-Band Performance

The X-band channels provide minimum noise temperatures of 13 to 14 Kelvin, referenced to the room-temperature waveguide flange, and gain of typically 34 to 36 dB. The gain variation over the 8.0 to 8.8 GHz range is less than 24 ± 1 dB. Gain from the cal input to the dewar output is 30 ± 2 dB below the waveguide input - dewar output gain. The input return loss is typically 15 to 20 dB; output return loss 5 to 10 dB; and cal return loss 15 to 20 dB.

The T_{short} data on the X-band data sheets is the equivalent input temperature of a short circuit connected to the waveguide input flange. This temperature should be the noise temperature of the cooled isolator, plus added noise of losses between the isolator and the waveguide short. Hence, this measured data gives an indication of the magnitude of these losses and is helpful when isolating problems. This test cannot be done on the S-band amplifiers, of course, because no cooled isolator is used.

4.3 Refrigeration Performance

A strip-chart recording of the S/N 03 dewar cool-down and warm-up times is given in Appendix B. The cool-down time is typically 6 hours and the warm-up time typically 1.5 hours. The refrigerator first stage typically reaches 55 to 65 Kelvin, and the second stage 12 to 15 Kelvin.

5.0 Acknowledgements

Funding for the development of these receivers was provided by the U. S. Naval Observatory, to upgrade the receivers on the three Green Bank 85-foot telescopes. R. Simmons did the construction and testing of the dewar and cardcage assemblies. M. Pospieszalski and W. Lakatosh designed and constructed the X-band amplifiers. S. Weinreb did much of the design for the VLBA circuit cards that were used or adapted for this project. The Green Bank machine shop fabricated all of the machined parts in the dewar, cardcage, and S-band amplifiers.

(B l a n k)

APPENDIX A

Bill of Material--Dewar Cardcage	A17211B001
Bill of Material--Dewar Assembly	A17211B002
Bill of Material--Monitor Card	A17211B003
Wiring List--Dewar Cardcage	A17211W001

Page No. 1 S/X DEWAR ASSEMBLY - A17211B001 - Dewar Cardcage
10/28/88

BILL OF MATERIALS
National Radio Astronomy Observatory
Green Bank, WV 24944

ITM	QTY	DESCRIPTION	PART NUMBER	MANUF
0	0	THIS IS - BOM, S/X DEWAR CARDCAGE	A17211B001	NRAO
1	0	REF - WIRING LIST	A17211W001	NRAO
2	1	CARDCAGE BOTTOM PLATE	C17211M002	NRAO
3	1	CARDCAGE SIDE 1 PLATE	D1721M003-01	NRAO
4	1	CARDCAGE SIDE 2 PLATE	D17211M003-02	NRAO
5	2	CARDCAGE SIDE RAIL	C17211M004	NRAO
6	1	CARDCAGE TOP PLATE	D17211M001	NRAO
7	1	CONNECTOR, 20 PIN, PANEL EXPOSED, J2		ELCO
8	1	CONNECTOR, 38 PIN, PANEL PROTECTED, J1		ELCO
9	2	CONNECTOR, 5 PIN, FEMALE, J3-J4	126-218	AMPHENOL
10	1	CONNECTOR, D25 FEMALE, J6	DBM-25S	TRW CINCH
11	1	CONNECTOR, HEATER AC, J5	H1061G	TOWER
12	6	EDGE CARD CONNECTOR, 44 PIN	50-44A-30	TRW CINCH
13	2	RESISTOR, CARBON, 1/2 W, R1-R2, 510 OHMS		
14	1	CARDCAGE CARD BRACKET	A53203M038	NRAO

Page No. 1 S/X DEWAR ASSEMBLY - A17211B002 - Dewar Assembly
04/06/89

BILL OF MATERIALS
National Radio Astronomy Observatory
Green Bank, WV 24944

ITM	QTY	DESCRIPTION	PART NUMBER	MANUF
0	0	THIS IS - BOM, S/X DEWAR ASSEMBLY	A17211B002	NRAO
1	1	ASSEMBLY, DEWAR CARD CAGE	A17211A001	NRAO
2	110	BRASS WIRE, 32AWG, INSULATED		MWS WIRE
3	0	CHARCOAL PELLETS	AC-4051	WILCO CHEM
4	5	COAX, .085 SS	JS-50085	PRES. TUBE
5	4	CONNECTOR, FET BIAS	EP-7S-1	MICROTECH
6	2	COUPLER, X-BAND, 30DB	C3206-30	MAC TECH
7	2	CRYOGENIC TEMP SENSOR	DT-471-DI	LAKE SHORE
8	2	DC FEEDTHRU ARTWORK	A53200I002	NRAO
9	2	DC FEEDTHRU PLATE	A53206M008	NRAO
10	1	DEWAR BODY	D17211M011	NRAO
11	1	DEWAR COVER PLATE	D17211M012	NRAO
12	1	DEWAR FEED PLATE	D17211M010	NRAO
13	1	ELCO-38 BRACKET	B17211M028	NRAO
14	0	EPOXY	A-12	ARMSTRONG
15	44	FEEDTHRU CAP, 1000pF, 200V	7648-1011-102	VICLAN
16	4	FEEDTHRU CAP, 3300pF, 500V	XS1F2-332H	US MICRO
17	2	HEATER CLAMP	A53206M056	NRAO
18	2	HEATER UNIT, 50W, 120V	SC252	HOTWATT
19	0	HEATER WIRE (USE INDIVIDUAL WIRES)	MS-7	MICROTECH
20	1	IRIS, X-BAND WINDOW PLATE	A53206M055-01	NRAO
21	2	ISOLATOR, X-BAND	ASI7011-3	FEI MW
22	2	O-RING, 350 REFRIGERATOR, CYLINDER	2-246	PARKER
23	2	O-RING, DC FEEDTHRU	2-130	PARKER
24	2	O-RING, DEWAR COVERS	2-283	PARKER
25	2	O-RING, S-BAND WAVEGUIDE	2-244	PARKER
26	1	O-RING, VACUUM FEEDTHRU	2-118	PARKER
27	2	O-RING, X-BAND CYLINDER	2-250	PARKER
28	4	PCB, FET BIAS	D53200A002	NRAO
29	1	PCB, MONITOR	B17211A003	NRAO
30	1	PCB, SENSOR	D53200A003	NRAO
31	1	POLARIZER, X-BAND	AMC0881	ATL MW
32	1	QUICK-RELEASE CLAMP, KF-50	18345	LEYBOLD
33	0	REF - W/G-COAX ADAPTER MODIFICATION	B17211M018	NRAO
34	1	REFRIGERATOR	MODEL 350	CTI
35	1	REFRIGERATOR CYLINDER	D17211M025	NRAO
36	4	S-BAND TRANSFER PLATE	B17211M008	NRAO
37	2	S-BAND TRANSITION PLATE	D17211M006	NRAO
38	12	S-BAND TRANSITION SUPPORT 1	B17211M009-01	NRAO
39	12	S-BAND TRANSITION SUPPORT 2	B17211M009-02	NRAO
40	2	S-BAND W/G-SMA ADAPTER	LA40-3A	MRC
41	2	S-BAND WAVEGUIDE ASSEMBLY	C17211M005	NRAO
42	1	SHIELD 1	D17211M021	NRAO
43	1	SHIELD 2	D17211M022	NRAO
44	1	SHIELD 3	D17211M023	NRAO

Page No. 2 S/X DEWAR ASSEMBLY - A17211B002 - Dewar Assembly
04/06/89

BILL OF MATERIALS
National Radio Astronomy Observatory
Green Bank, WV 24944

ITM	QTY	DESCRIPTION	PART NUMBER	MANUF
45	1	SHIELD 4	C17211M024	NRAO
46	16	SMA CONNECTOR, 085 CRIMP-ON	2001-7685-02	OMNI-SPEC
47	8	SMA CONNECTOR, 141 CRIMP-ON	2001-7641-02	OMNI-SPEC
48	8	SMA FEEDTHRU, HERMETIC	208A	OMNI-SPEC
49	1	STRAP, 70K	B17211M027	NRAO
50	2	TERMINATION, CAL COUPLER	SM8018-6005	SOLITRON
51	2	THERMOSTAT, OPEN-ON-RISE AT 140 F	2450-B201A-T107	ELMWOOD
52	1	VACUUM FEEDTHRU	B17211M013	NRAO
53	1	VACUUM SENSOR	DV-6R	TEL-HAST
54	1	VACUUM VALVE	FD-ILS-62	VACOA
55	2	W/G ADAPTER PLUG	B17211M029	NRAO
56	2	W/G ADAPTER PROBE	B17211M030	NRAO
57	1	X-BAND CYLINDER	D17211M015	NRAO
58	1	X-BAND POLARIZER MOUNT	D17211M014	NRAO
59	4	X-BAND TRANSITION SUPPORT	B17211M009-03	NRAO
60	1	X-BAND WAVEGUIDE	B17211M017	NRAO
61	1	X-BAND WINDOW	A53206M054-01	NRAO
62	1	X-BAND WINDOW PLATE	D17211M016	NRAO
63	1	15K PLATE	D17211M026-01	NRAO
64	1	15K-POLARIZER BRACKET	D17211M026-02	NRAO
65	2	QUARTZ DISK, SMA CONNECTOR	A2613M23	NRAO
66	2	COAX CONNECTOR, OUTSIDE, FEMALE	B2613M21	NRAO
67	2	CENTER PIN, FOR 0.075 THK QUARTZ BEAD	B2613M22	NRAO
68	2	MATCHING DISK	A2613M24	NRAO
69	0	INDIUM, 99.999%, 5 MIL		

Page No. 1 S/X DEWAR ASSEMBLY - A17211B003 - Monitor Card
09/23/88

BILL OF MATERIALS
National Radio Astronomy Observatory
Green Bank, WV 24944

ITM	QTY	DESCRIPTION	PART NUMBER	MANUF
0	0	THIS IS - BOM, MONITOR CARD	A17211B003	NRAO
2	1	MONITOR CARD FACE	B17211M019	NRAO
3	1	FACE SUPPORT	B17211M020-01	NRAO
4	1	METER CONNECTOR PLATE	A53200M032	NRAO
5	0	SILKSCREEN ART, MONITOR FACE	D17211Q001	NRAO
6	1	RES. 30 OHM, 1W, 5%	RC32GF300J	ALLEN-BRAD
7	2	RES. 200 OHMS, 1/4W, 5%	RC07GF201J	ALLEN-BRAD
8	6	RES. 2.0K, 1/4W, 5%	RC07GF202J	ALLEN-BRAD
9	5	RES. 1.0MEG, 1/4W, 5%	RC07GF105J	ALLEN-BRAD
10	1	CAP. 0.1UF, 50V	C330C104MSU5CA	KEMET
11	1	CAP. 1.0UF, 50V	C330C105MSU5CA	KEMET
12	1	CAP. 15UF, 20V, TANTALUM	CSR13E156KP	KEMET
13	1	CAP. 22UF, 20V, TANTALUM	CSR13E226KP	KEMET
14	1	VOLTAGE REGULATOR, 5V	MC7805CT	MOTOROLA
15	1	IC, ENCODER	SN74LS148N	TI
16	1	IC, DATA SELECTOR	SN74LS157N	TI
17	1	IC, QUAD OR	SN74LS32N	TI
18	1	IC, TRIPLE NAND	SN74LS12N	TI
19	1	METER, 20V FS, LCD	PM-45XU	TEXMATE
21	1	ROTARY SWITCH, 2 DECK, 1 POLE	71ADF30-02-1-AJN	GRAYHILL
22	1	KNOB FOR 1.8 SHAFT, POINTER STYLE	50-4-1	RAYTHEON
26	1	PIN JACK, PANEL MOUNT, BLACK	105-0803-001	EF JOHNSON
27	1	PIN JACK, PANEL MOUNT, GRAY	105-0813-001	EF JOHNSON
28	0	WIRE, 22AWG STRANDED, AS REQ'D		
29	1	4-40 X 5/16 SS FHS		ALL METAL
30	4	4-40 X 1/4 LG SS SHCSS		ALL METAL
31	2	4-40 X 1/2 LG SS SHCS		ALL METAL
32	1	4-40 SS HEX NUT		ALL METAL
33	1	#4, SS FLAT WASHER		ALL METAL
34	1	EDGE CONNECTOR, 20 PIN, FOR METER	CN-L10	TEXMATE
35	2	DIP SOCKET, 14 PIN	ICN-143-S3-X	ROB-NUGENT
36	2	DIP SOCKET, 16 PIN	ICN-163-S3-X	ROB-NUGENT
37	1	METER SUPPORT BAR	B17211M020-02	NRAO
38	2	MONITOR HANDLE	A53200M038	NRAO
39	2	MONITOR HANDLE CAP	A53200M037	NRAO

S/X DEWAR

CARD CAGE

WIRING LIST

Note:

All wire 22 AWG stranded.

Bus wire 18 AWG.

Ref: Bill Of Materials : A17211B001

October 28, 1988
By: R. D. Norrod

Dwg. No.: A17211W001
Sheet: 1 OF 12
Revision: A 10/27/88

CARD SLOT WIRING LIST

SYSTEM: S/X FRONT END
 ASS'Y: DEWAR CARD CAGE
 SLOT: 1
 CARD: MONITOR CARD

DWG. NO.: A17211W001
 DATE: October 28, 1988
 BY: R. D. NORROD
 SHEET: 2

PIN	FUNCTION	TO	COLOR	PIN	FUNCTION	TO	COLOR
A	GROUND	GND BUS J2-A	BUS ØXX	1	GROUND	GND BUS J2-X	BUS ØXX
B	+15 VOLTS	+15 BUS J2-B	BUS 2XX	2	+15 VOLTS	+15 BUS J2-W	BUS 2XX
C	-15 VOLTS	-15 BUS J2-C	BUS 4XX	3	-15 VOLTS	-15 BUS J2-V	BUS 4XX
D				4			
E	QUALITY GND	J2-U S2-J	ØXX	5			
F	AUX VAC MON	J2-D S6-14	8XX	6			
H	DEWAR VAC MON	J2-E S6-N	6XX	7			
J	15K MON (TEMP A)	J2-F S6-D	906	8			
K	50K MON (TEMP B)	J2-H S6-5	905	9			
L	S-LCP GATE MON	J2-J S2-7	90X	10			
M	S-RCP GATE MON	J2-K S3-7	904	11			
N	X-LCP GATE MON	J2-L S4-7	94X	12			
P	X-RCP GATE MON	J2-M S5-7	97X	13			
R	S-LED	J2-N* J1-h	5XX	14			
S	X-LED	J2-P* J1-j	1XX	15			
T	SPARE	GND BUS	ØXX	16			
U	SPARE	GND BUS	ØXX	17			
V				18			
W				19			
X	LED +15 VOLTS	S1-B*	2XX	20			
Y				21			
Z				22			

SPECIAL INSTRUCTIONS: * CONNECT R1 (510 OHM, 1/2 WATT CARBON, BOM ITEM 13) ACROSS PINS S1-R,X. CONNECT R2 (SECOND BOM ITEM 13) ACROSS S1-S,X. KEY BETWEEN PINS 3 AND 4.

CARD SLOT WIRING LIST

SYSTEM: S/X FRONT END
 ASS'Y: CARD CAGE
 SLOT: 2
 CARD: S-LCP FET BIAS

DWG. NO.: A17211W001
 DATE: March 18, 1988
 BY: R. D. NORROD
 SHEET: 3

PIN	FUNCTION	TO	COLOR	PIN	FUNCTION	TO	COLOR
A	GROUND	GND BUS	BUS	1	GROUND	GND BUS	BUS
B	+15 VOLTS	+15 BUS	BUS	2	+15 VOLTS	+15 BUS	BUS
C	-15 VOLTS	-15 BUS	BUS	3	-15 VOLTS	-15 BUS	BUS
D	GATE 4	N.C.		4	GATE 4 MON	N.C.	
E	GATE 3	J1-K	94X	5	GATE 3 MON	S2-6	BUS
F	GATE 2	J1-H	92X	6	GATE 2 MON	S2-5	BUS
H	GATE 1	J1-E	90X	7	GATE 1 MON	S2-7	
J	QUALITY GROUND	S1-E	0XX	8		S2-6	BUS
K	DRAIN 4	S3-J		9		S1-L	90X
L	DRAIN 3	N.C.		10			
M	DRAIN 2	J1-L	95X	11			
N	DRAIN 1	J1-J	93X	12			
P		J1-F	91X	13			
R				14			
S				15			
T				16			
U				17			
V				18			
W				19			
X				20			
Y				21			
Z	6 VOLT CONTROL	N.C.		22			

SPECIAL INSTRUCTIONS:
 KEY BETWEEN PINS 4 AND 5.

CARD SLOT WIRING LIST

SYSTEM: S/X FRONT END
 ASS'Y: CARD CAGE
 SLOT: 3
 CARD: S-RCP FET BIAS

DWG. NO.: A17211W001
 DATE: March 18, 1988
 BY: R. D. NORROD
 SHEET: 4

PIN	FUNCTION	TO	COLOR	PIN	FUNCTION	TO	COLOR
A	GROUND	GND BUS	BUS	1	GROUND	GND BUS	BUS
B	+15 VOLTS	+15 BUS	BUS	2	+15 VOLTS	+15 BUS	BUS
C	-15 VOLTS	-15 BUS	BUS	3	-15 VOLTS	-15 BUS	BUS
D	GATE 4	N.C.		4	GATE 4 MON	N.C.	
E	GATE 3	J1-S	3XX	5	GATE 3 MON	S3-6	BUS
F	GATE 2	J1-P	98X	6	GATE 2 MON	S3-5	BUS
H	GATE 1	J1-M	96X	7	GATE 1 MON	S3-7	BUS
J	QUALITY GROUND	S2-J	0XX	8		S3-6	BUS
K	DRAIN 4	S4-J		9		S1-M	904
L	DRAIN 3	N.C.		10			
M	DRAIN 2	J1-T	5XX	11			
N	DRAIN 1	J1-R	1XX	12			
P		J1-N	97X	13			
R				14			
S				15			
T				16			
U				17			
V				18			
W				19			
X				20			
Y				21			
Z	6 VOLT CONTROL	N.C.		22			

SPECIAL INSTRUCTIONS:

KEY BETWEEN PINS 4 AND 5.

CARD SLOT WIRING LIST

SYSTEM: S/X FRONT END
 ASS'Y: CARD CAGE
 SLOT: 4
 CARD: X-LCP FET BIAS

DWG. NO.: A17211W001
 DATE: October 28, 1988
 BY: R. D. NORROD
 SHEET: 5

PIN	FUNCTION	TO	COLOR	PIN	FUNCTION	TO	COLOR
A	GROUND	GND BUS	BUS	1	GROUND	GND BUS	BUS
B	+15 VOLTS	+15 BUS	BUS	2	+15 VOLTS	+15 BUS	BUS
C	-15 VOLTS	-15 BUS	BUS	3	-15 VOLTS	-15 BUS	BUS
D	GATE 4	N. C.		4	GATE 4 MON	N. C.	
E	GATE 3	J1-Y	905	5	GATE 3 MON	S4-6	BUS
F	GATE 2	J1-W	903	6	GATE 2 MON	S4-5	BUS
H	GATE 1	J1-U	901	7	GATE 1 MON	S4-7	BUS
J	QUALITY GROUND	S3-J	0XX	8		S4-6	BUS
K	DRAIN 4	S5-J		9		S1-N	94X
L	DRAIN 3	N. C.		10			
M	DRAIN 2	J1-Z	906	11			
N	DRAIN 1	J1-X	904	12			
P		J1-V	902	13			
R				14			
S				15			
T				16			
U				17			
V				18			
W				19			
X				20			
Y				21			
Z	6 VOLT CONTROL	N. C.		22			

SPECIAL INSTRUCTIONS:
 KEY BETWEEN PINS 4 AND 5.

CARD SLOT WIRING LIST

SYSTEM: S/X FRONT END
 ASS'Y: CARD CAGE
 SLOT: 5
 CARD: X-RCP FET BIAS

DWG. NO.: A17211W001
 DATE: March 18, 1988
 BY: R. D. NORROD
 SHEET: 6

PIN	FUNCTION	TO	COLOR	PIN	FUNCTION	TO	COLOR
A	GROUND	GND BUS	BUS	1	GROUND	GND BUS	BUS
B	+15 VOLTS	+15 BUS	BUS	2	+15 VOLTS	+15 BUS	BUS
C	-15 VOLTS	-15 BUS	BUS	3	-15 VOLTS	-15 BUS	BUS
D	GATE 4	N.C.		4	GATE 4 MON	N.C.	
E	GATE 3	J1-e	8XX	5	GATE 3 MON	S5-6	BUS
F	GATE 2	J1-c	6XX	6	GATE 2 MON	S5-5	BUS
H	GATE 1	J1-a	907	7	GATE 1 MON	S5-7 S5-6 S1-P	BUS BUS 97X
J	QUALITY GROUND	S4-J CHS GND	0XX	8			
K	DRAIN 4	N.C.		9			
L	DRAIN 3	J1-f	9XX	10			
M	DRAIN 2	J1-d	7XX	11			
N	DRAIN 1	J1-b	908	12			
P				13			
R				14			
S				15			
T				16			
U				17			
V				18			
W				19			
X				20			
Y				21			
Z	6 VOLT CONTROL	N.C.		22			

SPECIAL INSTRUCTIONS:

KEY BETWEEN PINS 4 AND 5.

CARD SLOT WIRING LIST

SYSTEM: S/X FRONT END
 ASS'Y: CARD CAGE
 SLOT: 6
 CARD: SENSOR CARD

DWG. NO.: A17211W001
 DATE: October 28, 1988
 BY: R. D. NORROD
 SHEET: 7

PIN	FUNCTION	TO	COLOR	PIN	FUNCTION	TO	COLOR
A	GROUND	GND BUS CHAS GND	BUS	1	GROUND	GND BUS CHAS GND	BUS
B	+15 VOLTS	+15 BUS	BUS	2	+15 VOLTS	+15 BUS	BUS
C	-15 VOLTS	-15 BUS	BUS	3	-15 VOLTS	-15 BUS	BUS
D	A MON OUT (15K)	S1-J	906	4	SENSOR A (15K)	J1-A	96X
E	SENSOR A RTN	J1-B S6-F	0XX BUS	5	B MON OUT (50K)	S1-K	905
F	SENSOR B RTN	J1-D S6-E	0XX BUS	6			
H	SENSOR B	J1-C	95X	7			
J	VAC TUBE DWR-1	J3-A	0XX	8			
K	VAC TUBE DWR-2	J3-B	5XX	9			
L	VAC TUBE DWR-3	J3-D	1XX	10			
M	VAC DWR LOCAL MON	N. C.		11			
N	VAC DWR MON	S1-H	6XX	12			
P				13			
R				14	VAC PUMP MON	S1-F	8XX
S	TEMP SENS A	N. C.		15			
T	TEMP SENS B	N. C.		16			
U				17	VAC TUBE PUMP-3	J4-D	1XX
V				18			
W				19			
X				20			
Y				21	VAC TUBE PUMP-1	J4-A	0XX
Z				22	VAC TUBE PUMP-2	J4-B	5XX

SPECIAL INSTRUCTIONS:
 KEY BETWEEN PINS 5 AND 6.

ELCO 38 PIN WIRING LIST

SYSTEM: S/X FRONT END
 ASS'Y: DEWAR CARD CAGE
 TYPE: PANEL, PROTECTED PINS
 KEY: 1 & 1
 FUNC'T: DEWAR CONNECTIONS

DWG. NO.: A17211W001
 DATE: March 18, 1988
 BY: R. NORROD
 SHEET: 8
 DESIGNATION: J1

PIN FUNCTION	TO	COLOR	PIN FUNCTION	TO	COLOR
A SENSOR A (15K)	S6-4	96X	Y X-L GATE 3	S4-E	905
B SENSOR A RTN	S6-E	0XX	Z X-L DRAIN 3	S4-L	906
C SENSOR B (50K)	S6-H	95X	a X-R GATE 1	S5-H	907
D SENSOR B RTN	S6-F	0XX	b X-R DRAIN 1	S5-N	908
E S-L GATE 1	S2-H	90X	c X-R GATE 2	S5-F	6XX
F S-L DRAIN 1	S2-N	91X	d X-R DRAIN 2	S5-M	7XX
H S-L GATE 2	S2-F	92X	e X-R GATE 3	S5-E	8XX
J S-L DRAIN 2	S2-M	93X	f X-R DRAIN 3	S5-L	9XX
K S-L GATE 3	S2-E	94X	h S-LED	S1-R	5XX
L S-L DRAIN 3	S2-L	95X	j X-LED	S1-S	1XX
M S-R GATE 1	S3-H	96X	k		
N S-R DRAIN 1	S3-N	97X	l		
P S-R GATE 2	S3-F	98X	m		
R S-R DRAIN 2	S3-M	1XX	n HEATER - 1	J5-HI	98X*
S S-R GATE 3	S3-E	3XX	p HEATER - 2	J5-LO	8XX*
T S-R DRAIN 3	S3-L	5XX	r		
U X-L GATE 1	S4-H	901	s GND	GND BUS	0XX
V X-L DRAIN 1	S4-N	902	t GND	GND BUS	0XX
W X-L GATE 2	S4-F	903			
X X-L DRAIN 2	S4-M	904			

SPECIAL INSTRUCTIONS: * TWIST TWO HEATER WIRES AND ROUTE AWAY FROM SIGNAL WIRES AS MUCH AS PRACTICAL.

ELCO 20 PIN WIRING LIST

SYSTEM: S/X FRONT END
 ASS'Y: DEWAR CARD CAGE
 TYPE: PANEL MOUNT, EXPOSED PINS
 KEY: 1 & 1
 FUNC'T: POWER/MONITOR

DWG. NO.: A17211W001
 DATE: March 18, 1988
 BY: R. NORROD
 SHEET: 9
 DESIGNATION: J2

PIN	FUNCTION	TO	COLOR
A	GND	S1-A J6-1	0XX
B	+15 V	S1-B J6-2	2XX
C	-15 V	S1-C J6-3	4XX
D	AUX VAC MON	S1-F J6-4	8XX
E	DEWAR VAC MON	S1-H J6-5	6XX
F	15K MON (TEMP A)	S1-J J6-6	906
H	50K MON (TEMP B)	S1-K J6-7	905
J	S-L GATE MON	S1-L J6-8	90X
K	S-R GATE MON	S1-M J6-9	904
L	X-L GATE MON	S1-N J6-10	94X
M	X-R GATE MON	S1-P J6-11	97X
N	S-LED MON	S1-R J6-12	5XX
P	X-LED MON	S1-S J6-13	1XX
R			
S			
T			
U	QUALITY GND	S1-E J6-17	0XX
V	-15 V	S1-3 J6-18	4XX
W	+15 V	S1-2 J6-19	2XX
X	GND	S1-1 J6-20	0XX

SPECIAL INSTRUCTIONS:

AMPHENOL 126 - 5 PIN CONNECTOR WIRING LIST

SYSTEM: S/X FRONT END
 ASS'Y: DEWAR CARD CAGE
 TYPE: PANEL
 SEX: FEMALE PINS
 FUNC'T: DEWAR VACUUM SENSOR

DWG. NO.: A17211W001
 DATE: March 18, 1988
 BY: R. NORROD
 SHEET: 10
 DESIGNATION: J3

PIN	FUNCTION	TO	COLOR
A	VAC TUBE (PIN 3)	S6-J	0XX
B	VAC TUBE (PIN 5)	S6-K	5XX
D	VAC TUBE (PIN 7)	S6-L	1XX
E			
H			

SPECIAL INSTRUCTIONS:

AMPHENOL 126 - 5 PIN CONNECTOR WIRING LIST

SYSTEM: S/X FRONT END
 ASS'Y: DEWAR CARD CAGE
 TYPE: PANEL
 SEX: FEMALE PINS
 FUNC'T: AUX VACUUM SENSOR

DWG. NO.: A17211W001
 DATE: March 18, 1988
 BY: R. NORROD
 SHEET: 11
 DESIGNATION: J4

PIN	FUNCTION	TO	COLOR
A	VAC TUBE (PIN 3)	S6-21	ØXX
B	VAC TUBE (PIN 5)	S6-22	5XX
D	VAC TUBE (PIN 7)	S6-17	1XX
E			
H			

SPECIAL INSTRUCTIONS:

25 PIN D-CONNECTOR WIRING LIST

SYSTEM: S/X FRONT END
 ASS'Y: DEWAR CARD CAGE
 TYPE: PANEL
 SEX: FEMALE PINS
 FUNC'T: AUX MONITOR

DWG. NO.: A17211W001
 DATE: March 18, 1988
 BY: R. NORROD
 SHEET: 12
 DESIGNATION: J6

PIN	FUNCTION	TO	COLOR	PIN	FUNCTION	TO	COLOR
1	GND	J2-A	0XX	14			
2	+15V	J2-B	2XX	15			
3	-15V	J2-C	4XX	16			
4	AUX VAC MON	J2-D	8XX	17	QUALITY GND	J2-U	0XX
5	DEWAR VAC MON	J2-E	6XX	18	-15V	J2-V	4XX
6	15K MON	J2-F	906	19	+15V	J2-W	2XX
7	50K MON	J2-H	905	20	GND	J2-X	0XX
8	S-LCP GATE MON	J2-J	90X	21			
9	S-RCP GATE MON	J2-K	904	22			
10	X-LCP GATE MON	J2-L	94X	23			
11	X-RCP GATE MON	J2-M	97X	24			
12	S-LED MON	J2-N	5XX	25			
13	X-LED MON	J2-P	1XX				

SPECIAL INSTRUCTIONS:

APPENDIX B

Dewar Test Data

S/X Receiver Calibration Record 03/22/89 13:20:34
 RCP Polarization, Tested by SIMMONS
 Comment : S-BAND RCP: Tln = 78; Tcold = 83; That = 305.5:

S/X Receiver Monitor Values:

15K Temp = 14.2 50K Temp = 61.1
 Dewr Vac = 9037
 FETS: S-L = -0.615 S-R = -0.714 X-L = -0.723 X-R = -0.858
 S LED = 4.83 X LED = 5.68
 +15 Volt = 14.94 -15 Volt = -15.09

Tcold = 83.0 K That = 305.5 K

F (MHz)	Trx (K)	Tcal (K)	Thical (K)	Tshort (K)
2000.0	17.1	0.0	0.0	0.0
2025.0	23.3	0.0	0.0	0.0
2050.0	29.1	0.0	0.0	0.0
2075.0	15.9	0.0	0.0	0.0
2100.0	10.0	0.0	0.0	0.0
2125.0	9.3	0.0	0.0	0.0
2150.0	9.2	0.0	0.0	0.0
2175.0	9.4	0.0	0.0	0.0
2200.0	9.2	0.0	0.0	0.0
2225.0	9.1	0.0	0.0	0.0
2250.0	9.1	0.0	0.0	0.0
2275.0	9.1	0.0	0.0	0.0
2300.0	9.7	0.0	0.0	0.0
2325.0	9.7	0.0	0.0	0.0
2350.0	9.6	0.0	0.0	0.0
2375.0	9.2	0.0	0.0	0.0
2400.0	9.1	0.0	0.0	0.0
2425.0	10.2	0.0	0.0	0.0
2450.0	10.0	0.0	0.0	0.0
2475.0	11.2	0.0	0.0	0.0
2500.0	12.1	0.0	0.0	0.0

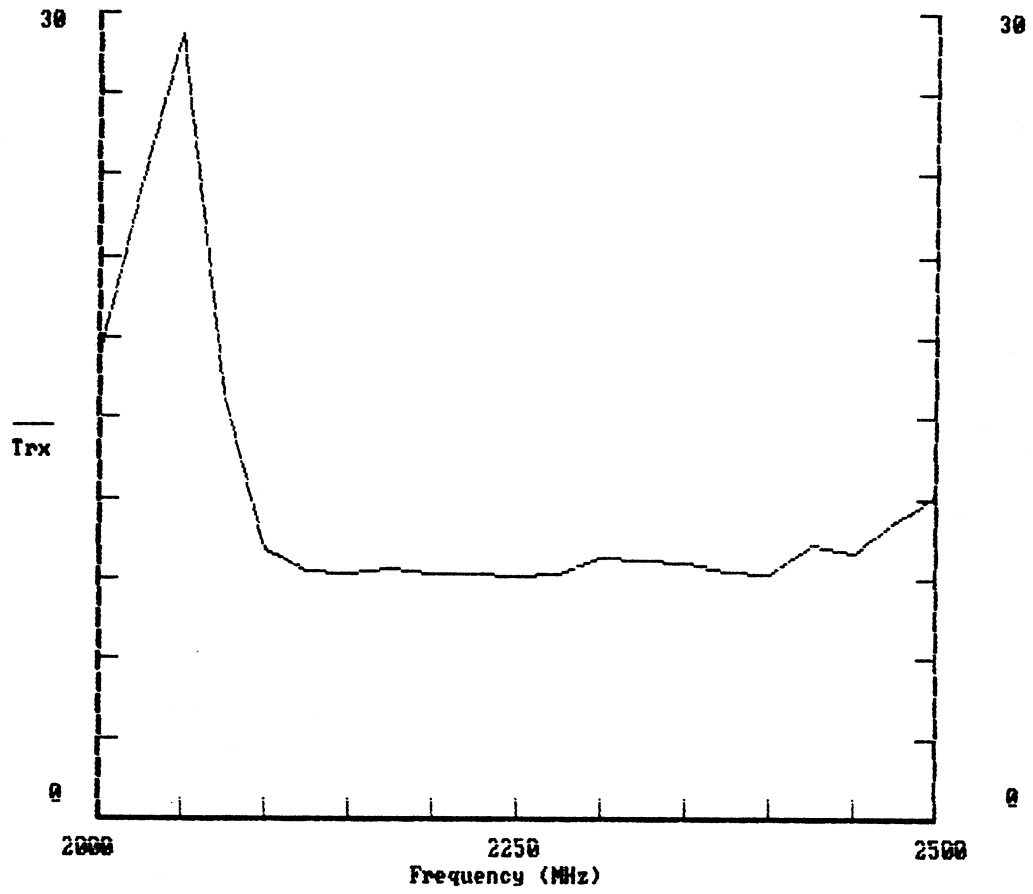

S/X DEWAR SN 03 S-BAND
03/22/89 13:20:55

S/X Receiver Calibration Record 03/22/89 11:12:11
 LCP Polarization. Tested by SIMMONS
 Comment : S-BAND LCP: Tln = 78; Tcold = 83; That = 304.5;

S/X Receiver Monitor Values:

15K Temp = 14.2 50K Temp = 61.1
 Dewr Vac = 9037
 FETS: S-L = -0.615 S-R = -0.714 X-L = -0.723 X-R = -0.858
 S LED = 4.83 X LED = 5.68
 +15 Volt = 14.94 -15 Volt = -15.09

Tcold = 83.0 K That = 304.5 K

F (MHz)	Trx (K)	Tcal (K)	Thical (K)	Tshort (K)
2000.0	14.4	0.0	0.0	0.0
2025.0	25.3	0.0	0.0	0.0
2050.0	31.7	0.0	0.0	0.0
2075.0	14.2	0.0	0.0	0.0
2100.0	12.1	0.0	0.0	0.0
2125.0	12.5	0.0	0.0	0.0
2150.0	11.4	0.0	0.0	0.0
2175.0	11.1	0.0	0.0	0.0
2200.0	11.0	0.0	0.0	0.0
2225.0	10.9	0.0	0.0	0.0
2250.0	10.7	0.0	0.0	0.0
2275.0	11.2	0.0	0.0	0.0
2300.0	11.7	0.0	0.0	0.0
2325.0	11.8	0.0	0.0	0.0
2350.0	11.7	0.0	0.0	0.0
2375.0	11.6	0.0	0.0	0.0
2400.0	11.3	0.0	0.0	0.0
2425.0	11.3	0.0	0.0	0.0
2450.0	10.3	0.0	0.0	0.0
2475.0	11.2	0.0	0.0	0.0
2500.0	13.1	0.0	0.0	0.0

B-4

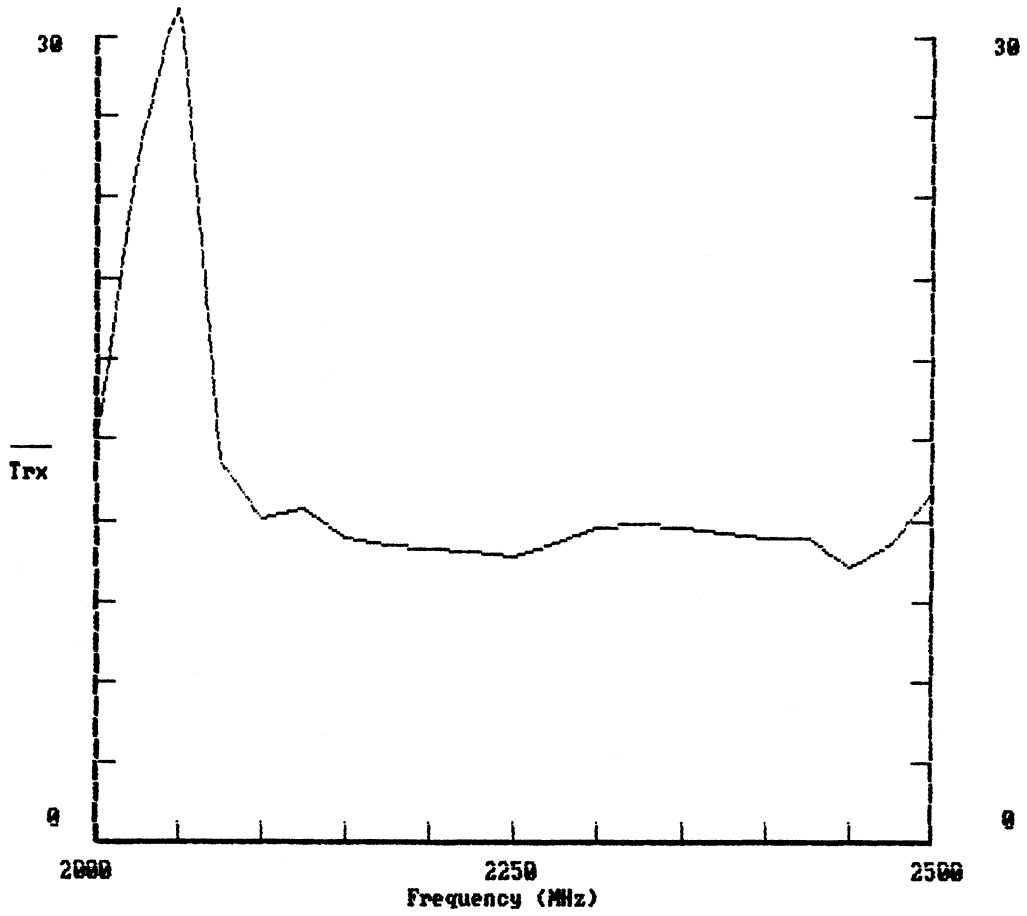

S/X DEMAR SN 03 S-BAND
03/22/89 11:13:12

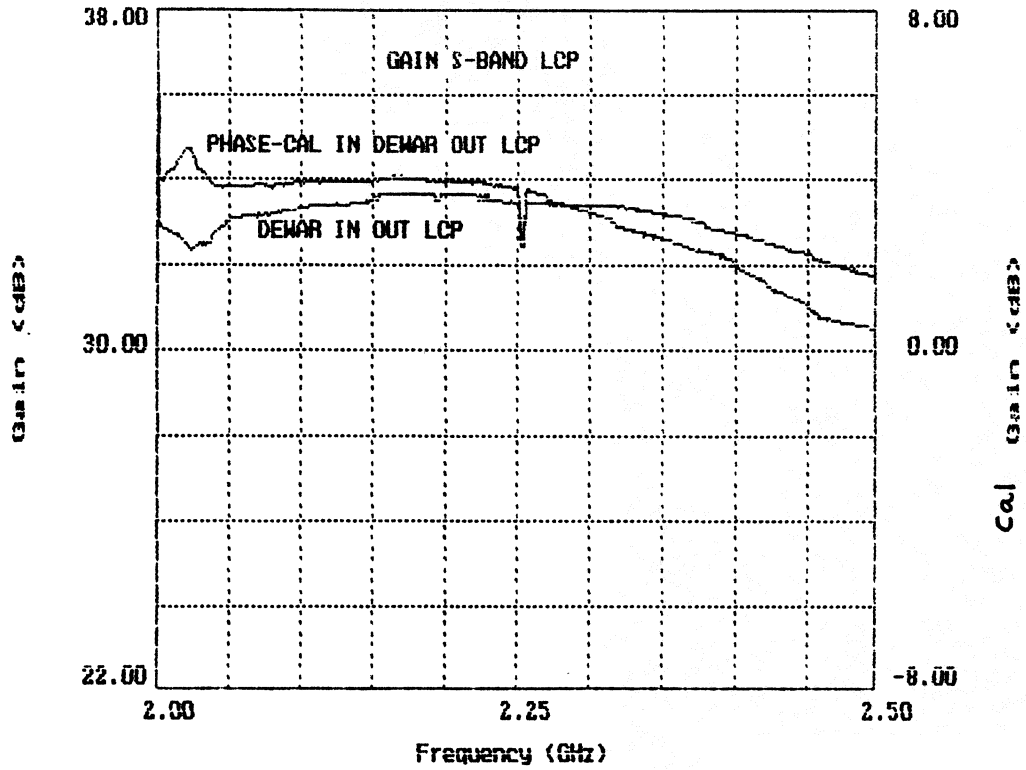

S/X DEWAR, SN 03, S-BAND
3/22/89

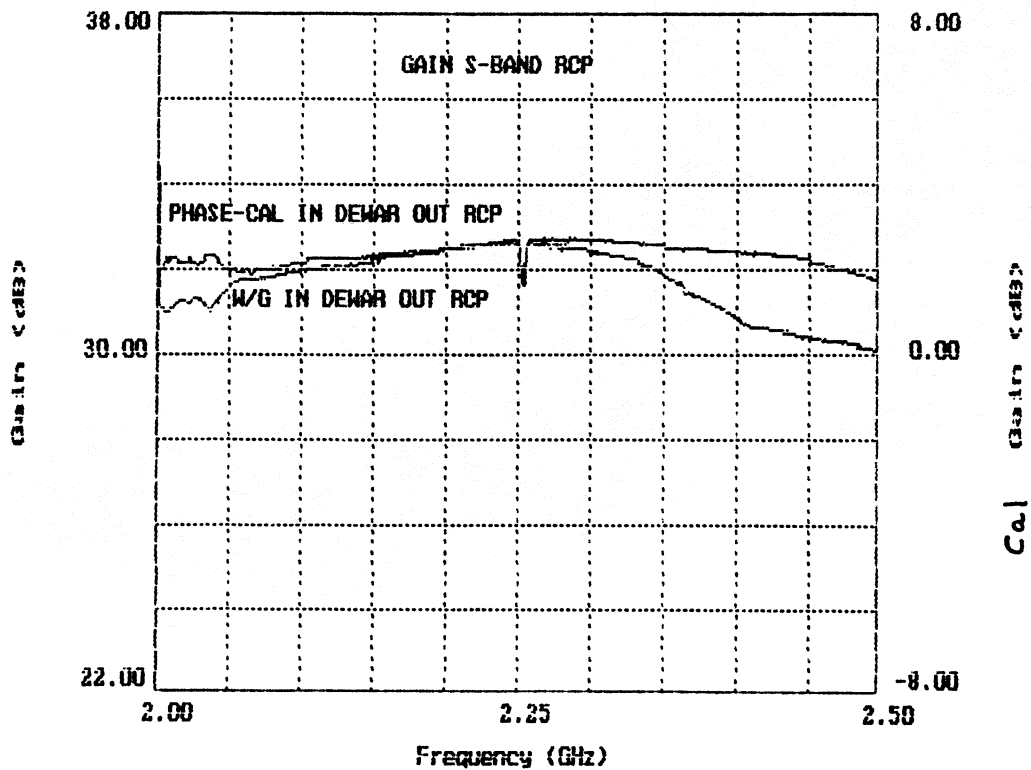

S/X DEWAR, SN 03, S-BAND
3/22/89

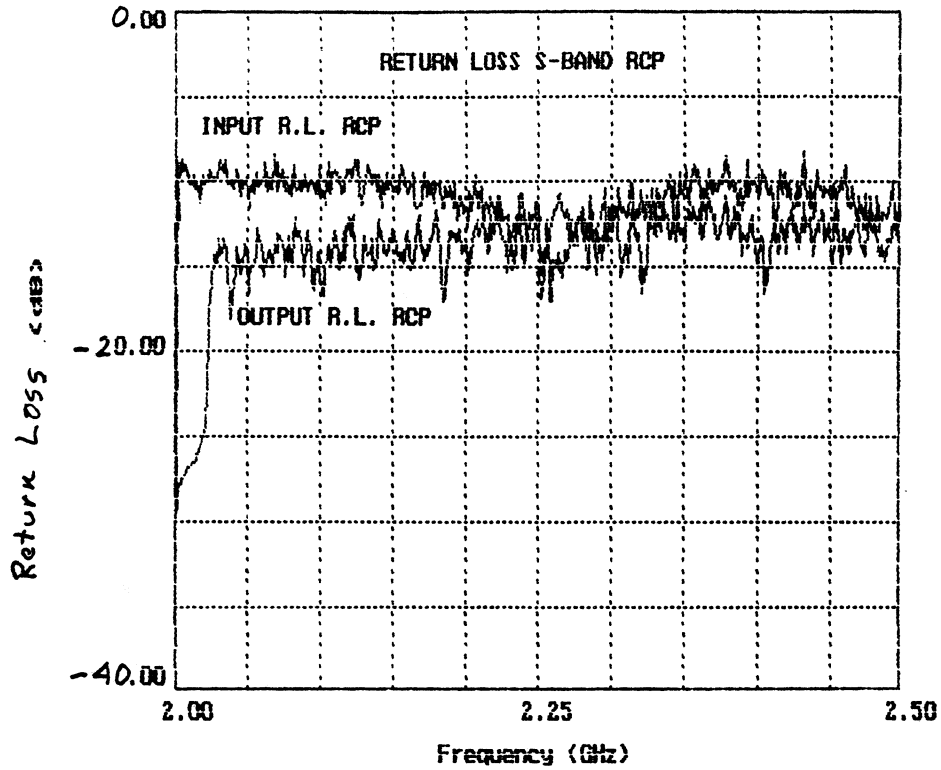

S/X DEMAR, SN 03, S-BAND
3/22/89

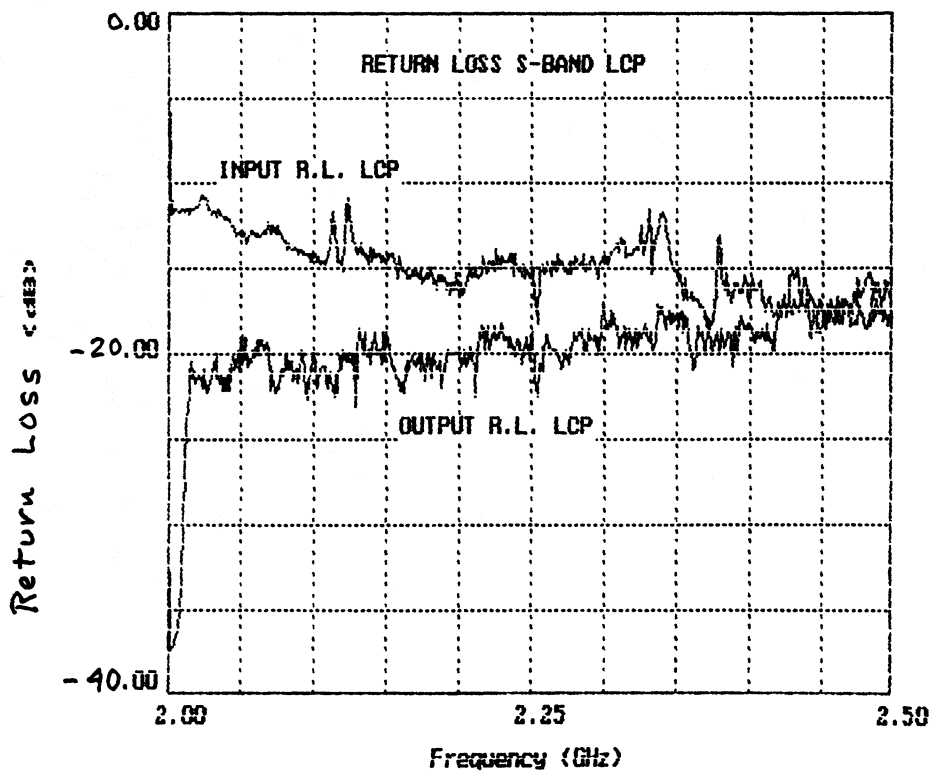

S/X DEMAR, SN 03, S-BAND
3/22/89

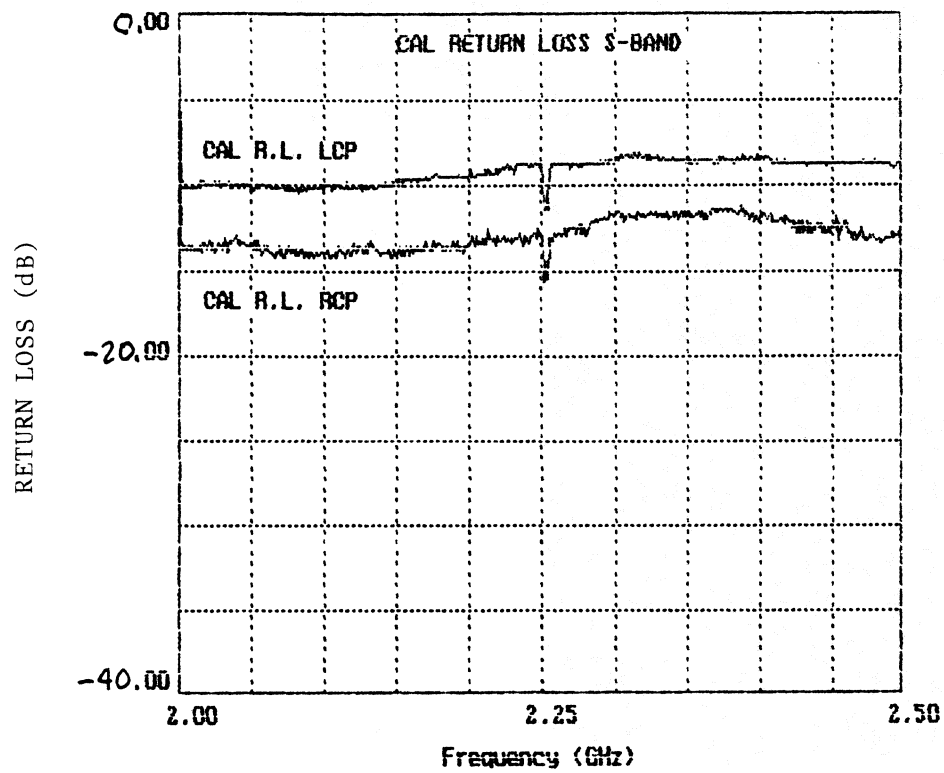

S/X DEMAR, SN 03, S-BAND

3/22/89

S/X Receiver Calibration Record 03/23/89 09:22:30
 LCP Polarization, Tested by SIMMONS
 Comment : X-BAND LCP: Tin = 78; Tcold = 78.7; Thot = 298:

S/X Receiver Monitor Values:

15K Temp = 14.5 50K Temp = 61.9
 Dewr Vac = 9043
 FETS: S-L = -0.632 S-R = -0.726 X-L = -0.758 X-R = -0.931
 S LED = 4.93 X LED = 5.68
 +15 Volt = 14.94 -15 Volt = -15.10

Tcold = 78.7 K Thot = 298.0 K

F (MHz)	Trx (K)	Tcal (K)	Thical (K)	Tshort (K)
8000.0	16.9	0.0	0.0	17.6
8080.0	13.9	0.0	0.0	17.8
8160.0	13.3	0.0	0.0	17.4
8240.0	13.5	0.0	0.0	17.0
8320.0	13.2	0.0	0.0	16.6
8400.0	12.7	0.0	0.0	16.5
8480.0	12.6	0.0	0.0	16.2
8560.0	13.1	0.0	0.0	15.4
8640.0	13.0	0.0	0.0	15.8
8720.0	14.8	0.0	0.0	16.0
8800.0	22.6	0.0	0.0	15.4

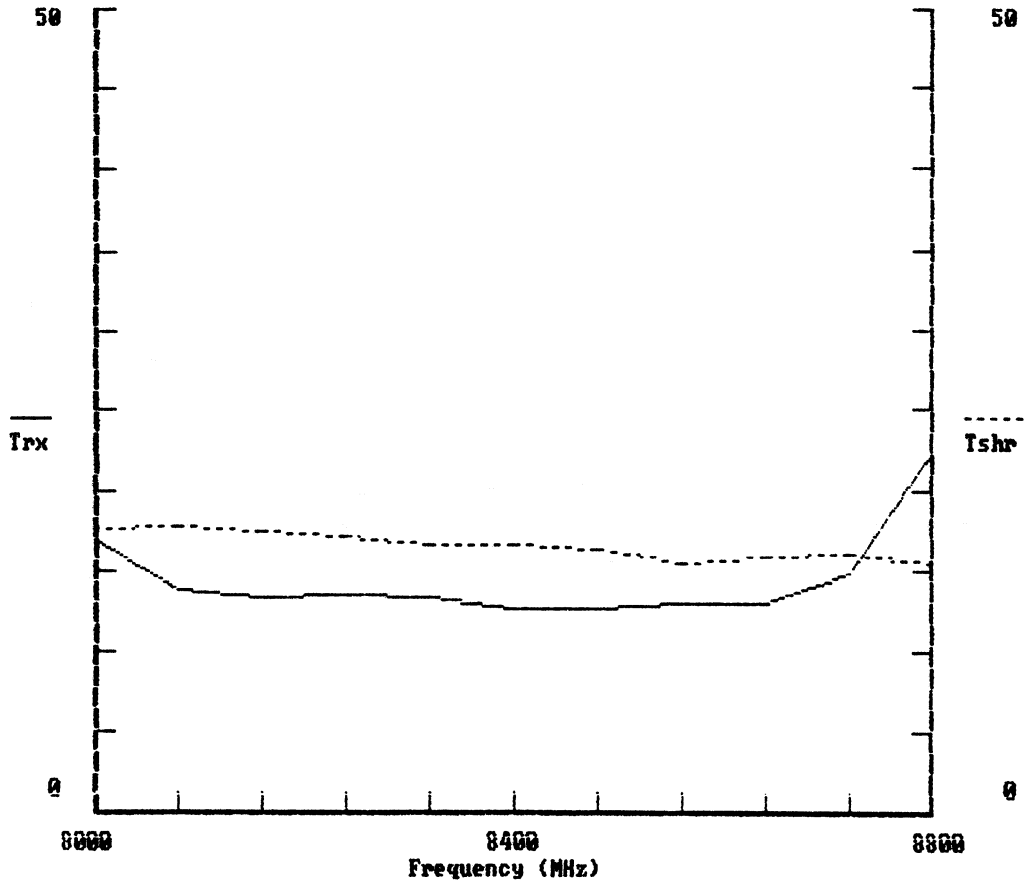

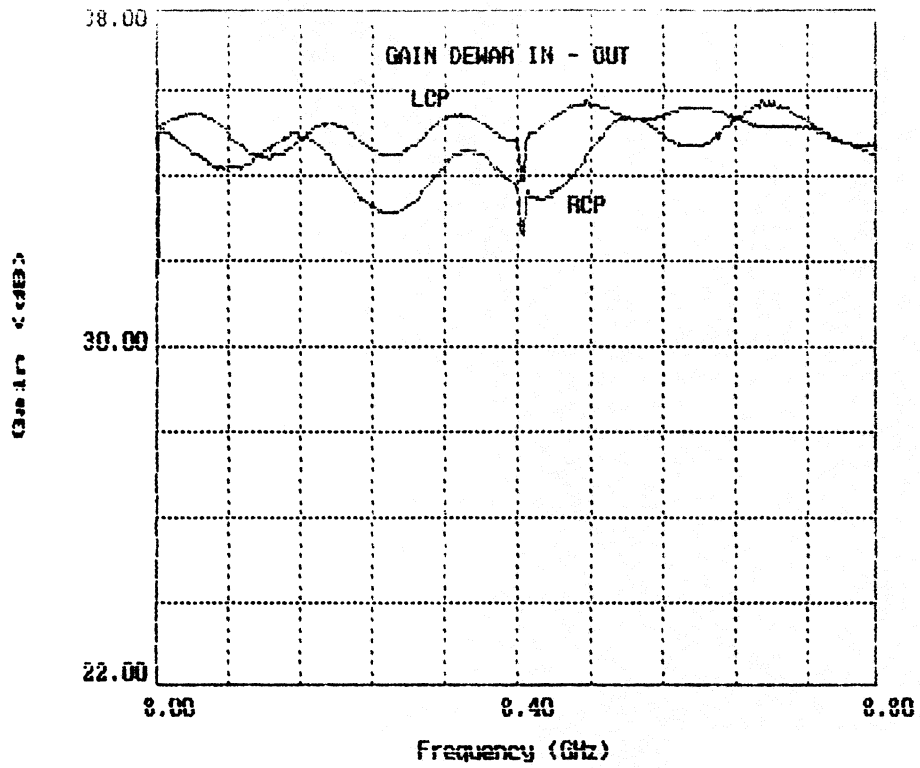

S/X DEWAR, SN 03, X-BAND
3/23/89

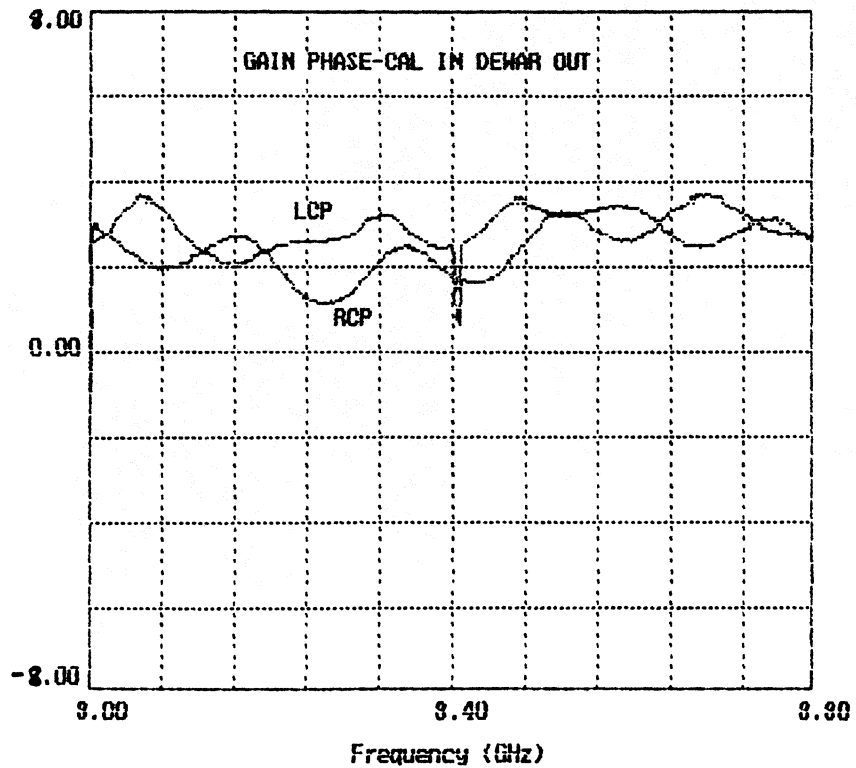

S/X DEWAR, SN 03, X-BAND
3/23/89

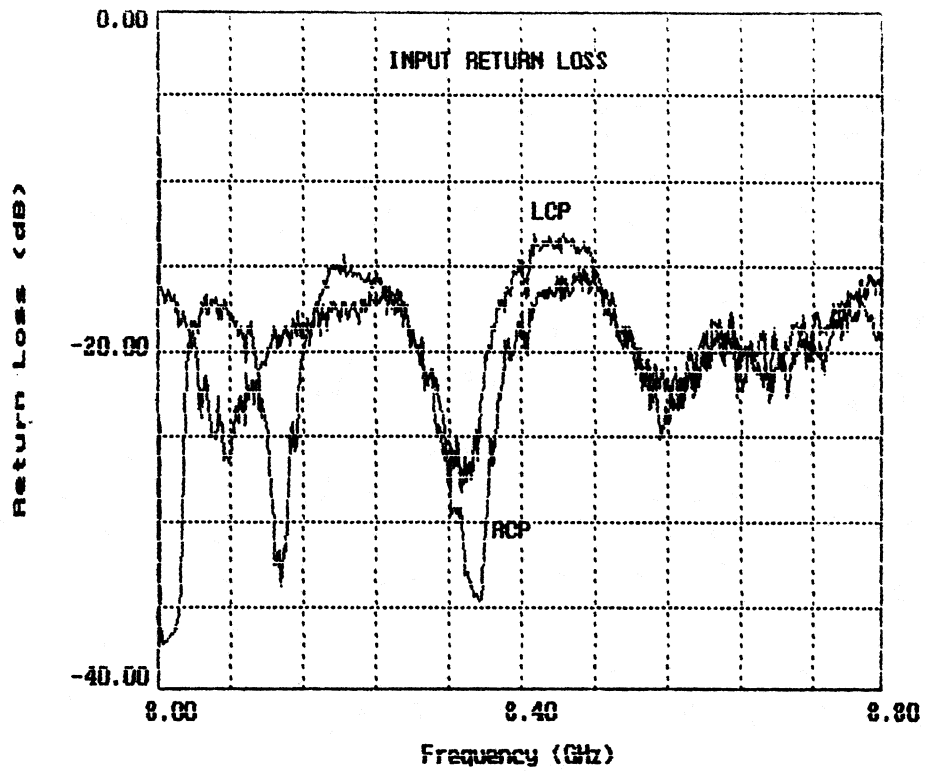

S/X DEMAR, SN 03, X-BAND
3/23/89

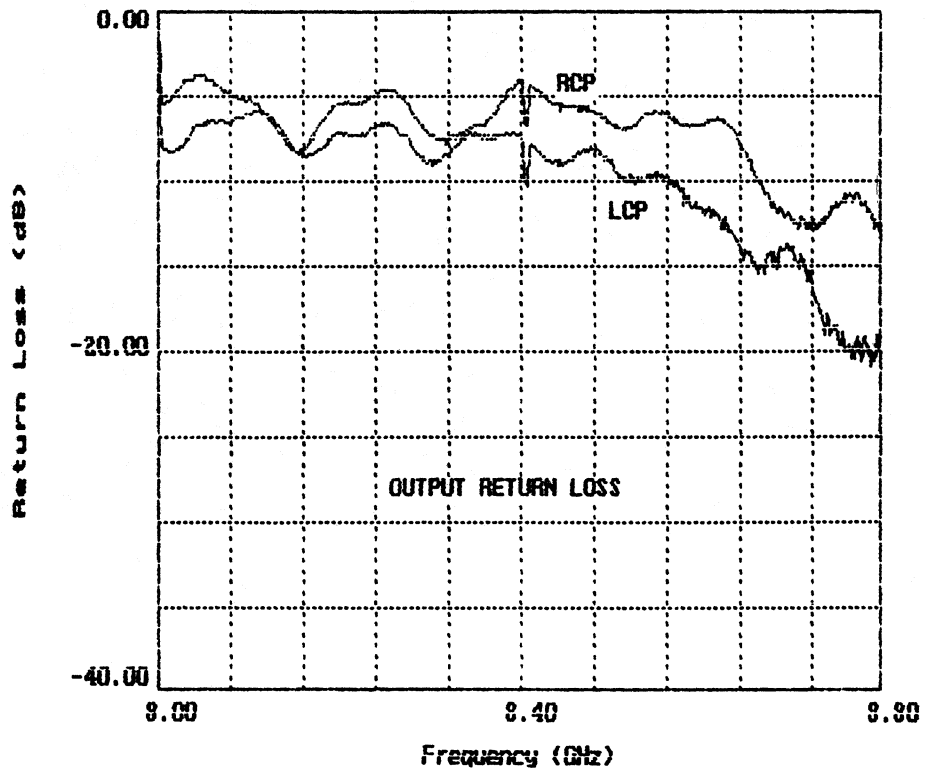

S/X DEMAR, SN 03, X-BAND
3/23/89

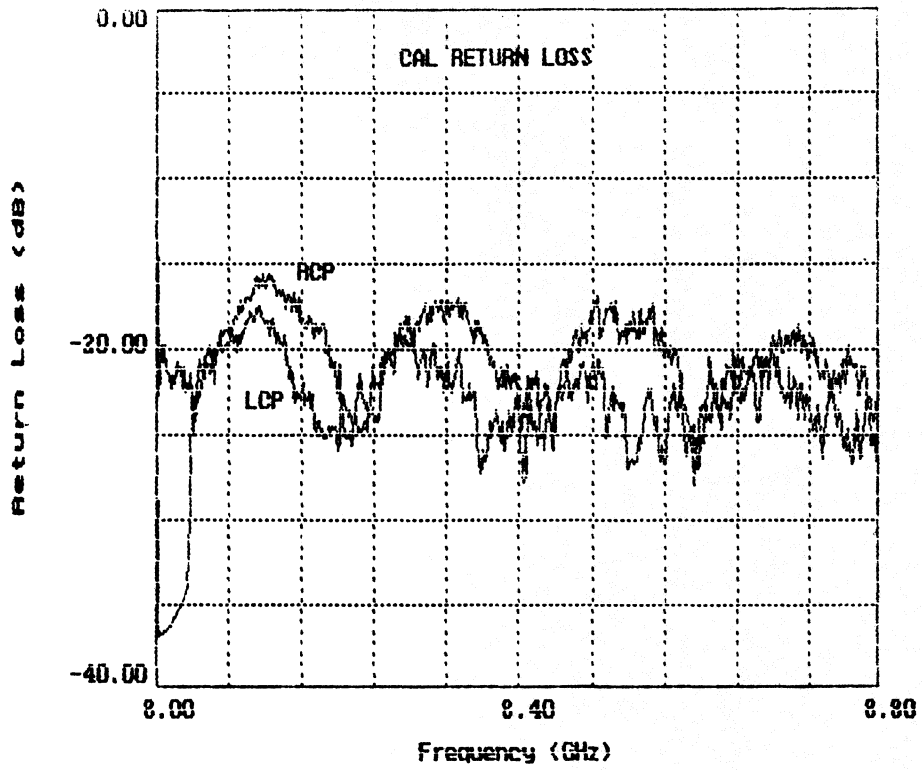

S/X DEMAR, SN 03, X-BAND

3/23/89

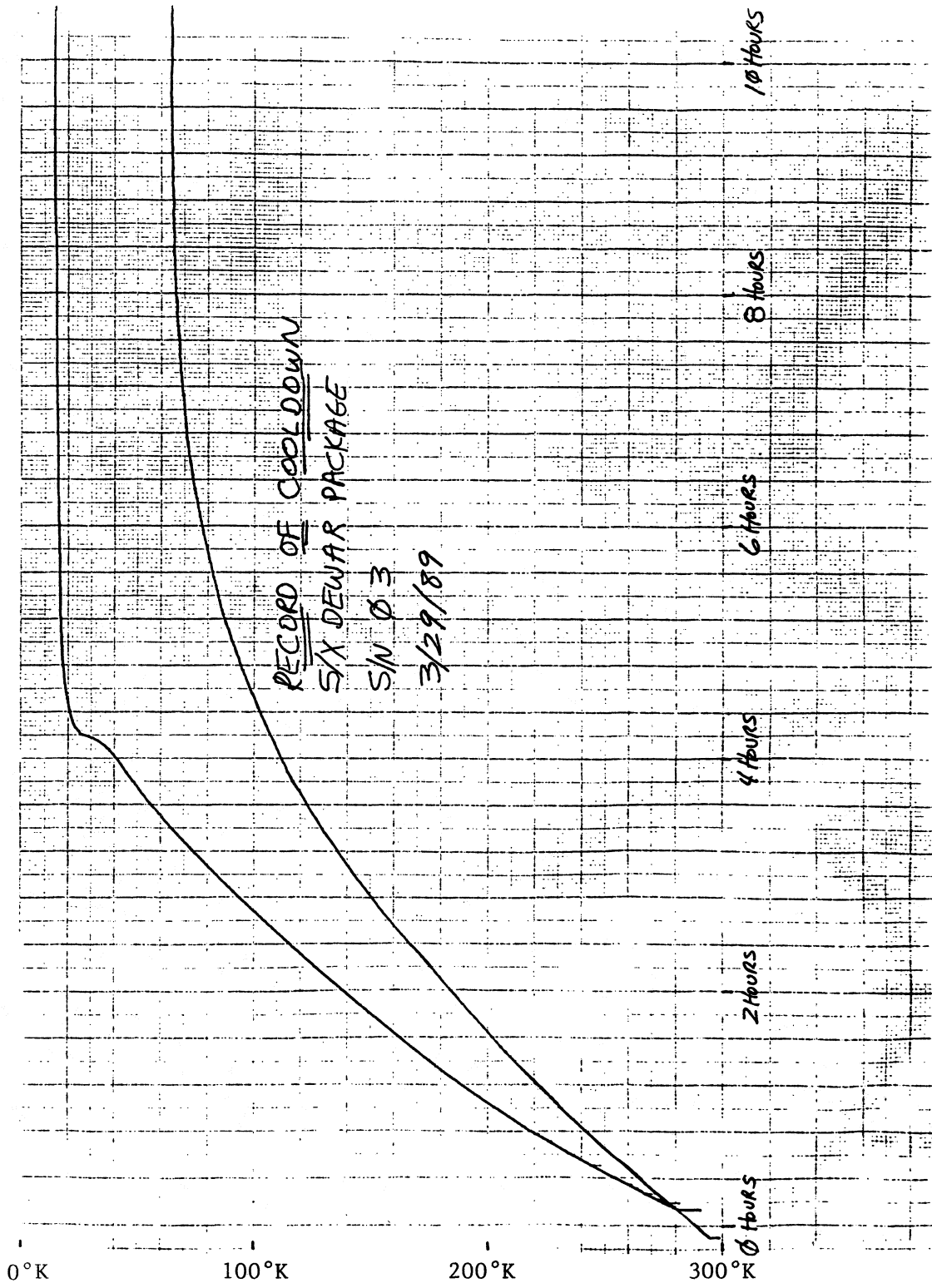

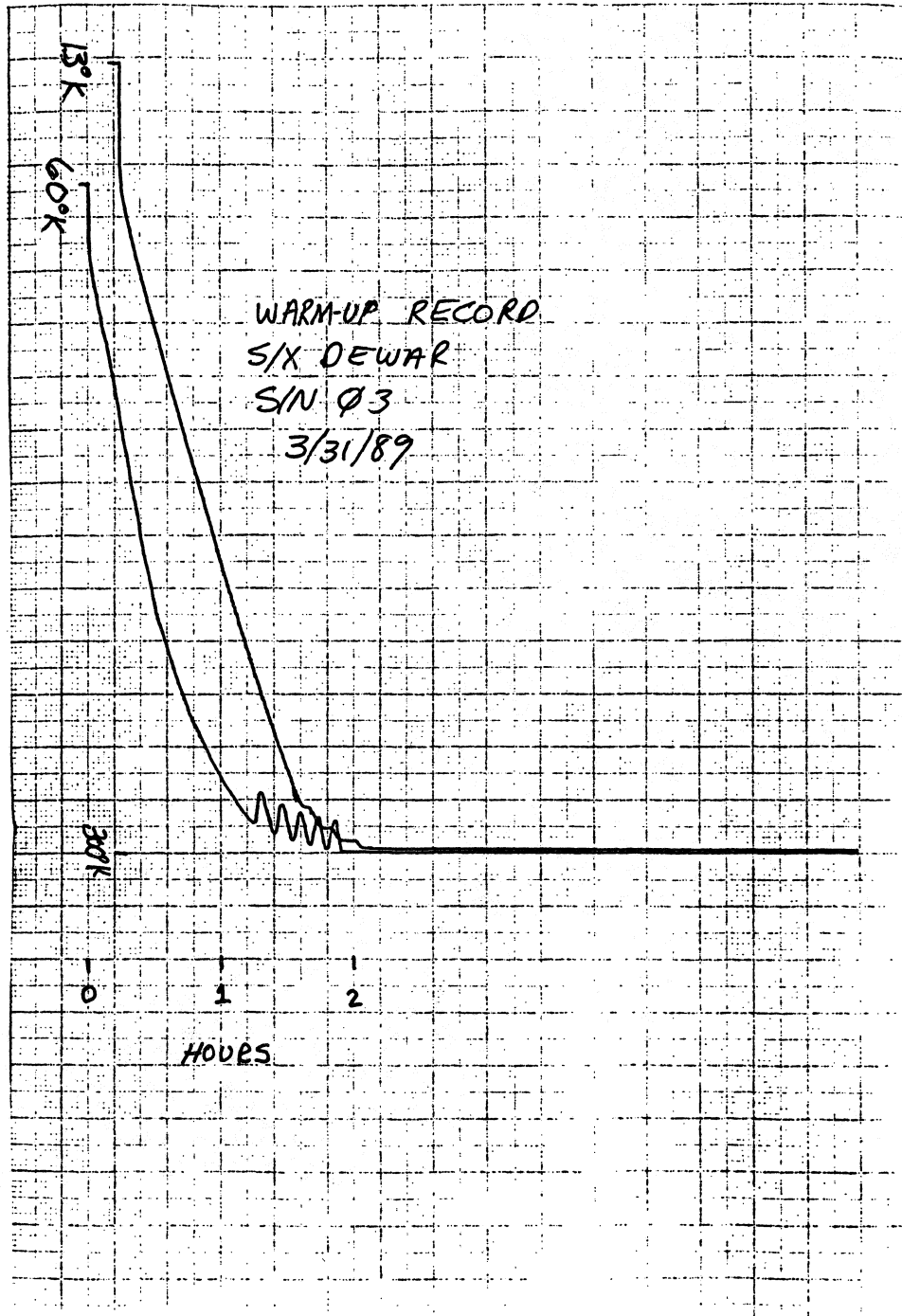

APPENDIX C

Component Manufacturers' Data Sheets

OCT 84

CRYODYNE® MODEL 350 SC CRYOGENIC REFRIGERATION SYSTEM

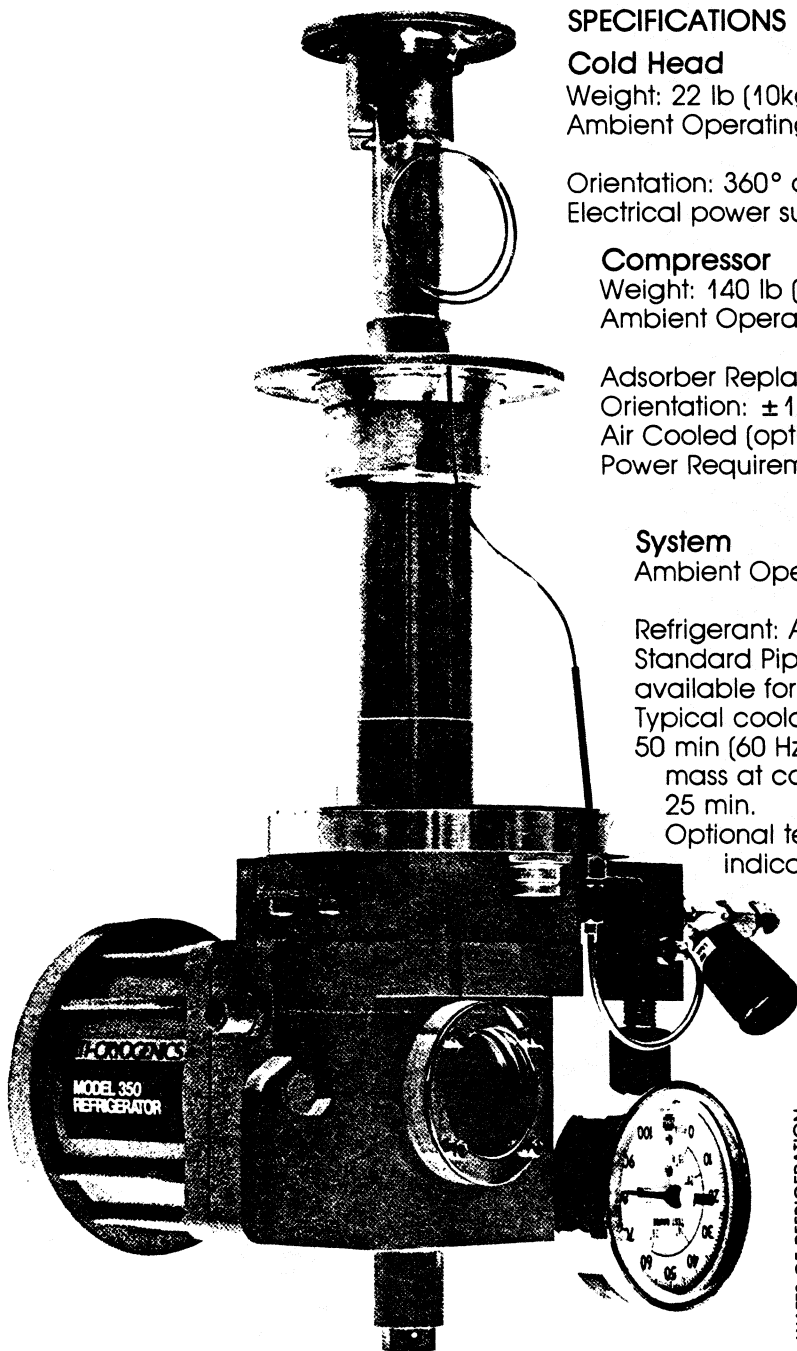

SPECIFICATIONS

Cold Head

Weight: 22 lb (10kg)

Ambient Operating Range: -25°F to 125°F
(-32°C to 52°C)

Orientation: 360° any plane

Electrical power supplied through compressor

Compressor

Weight: 140 lb (59kg) approx.

Ambient Operating Range: 60°F to 100°F
(16°C to 38°C)

Adsorber Replacement: 10,000 hours

Orientation: $\pm 10^{\circ}$ from horizontal

Air Cooled (optional water cooled available)

Power Requirements: 1.5kW 208/230 vac, 1 ϕ ,
50/60 Hz

System

Ambient Operating Range: 60°F to 100°F
(16°C to 38°C)

Refrigerant: Ambient temperature helium gas

Standard Piping: 10 feet. Optional piping
available for separation distances up to 500 feet.

Typical cooldown time to 20K with no load:

50 min (60 Hz), 65 min (50 Hz). Each lb (.45kg)
mass at cold end increases cooldown time
25 min.

Optional temperature sensors and
indicators are available.

Cooling
Capacity*

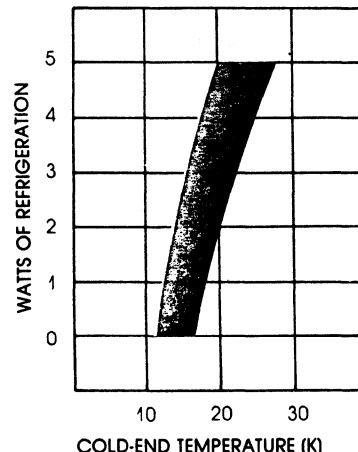

* Cold head performance will be within limits given here

CTI-CRYOGENICS

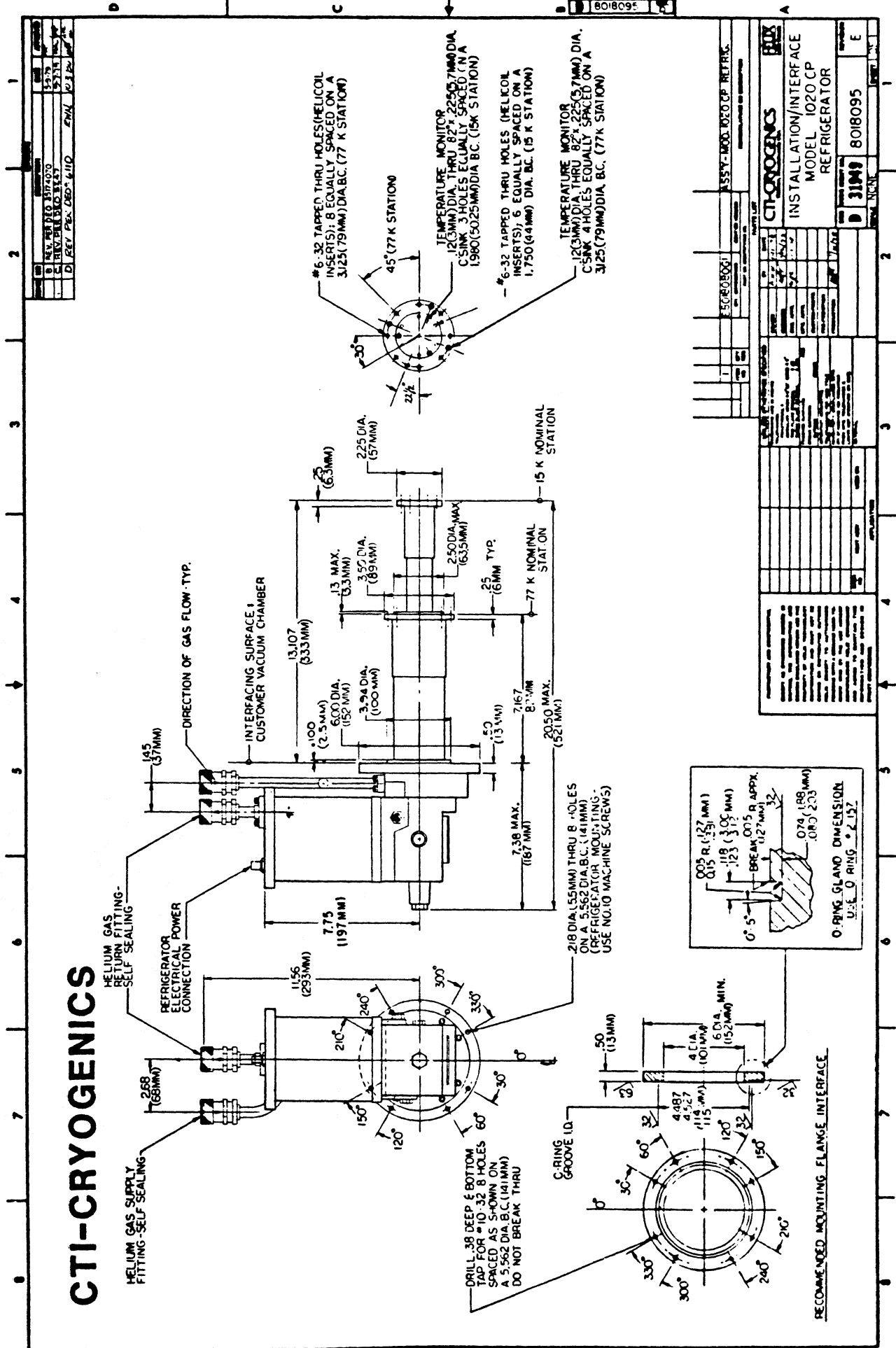

REV. 01	1574200	1575
REV. 02	1574200	1575
REV. 03	1574200	1575
REV. 04	1574200	1575
REV. 05	1574200	1575
REV. 06	1574200	1575
REV. 07	1574200	1575
REV. 08	1574200	1575
REV. 09	1574200	1575
REV. 10	1574200	1575
REV. 11	1574200	1575
REV. 12	1574200	1575
REV. 13	1574200	1575
REV. 14	1574200	1575
REV. 15	1574200	1575
REV. 16	1574200	1575
REV. 17	1574200	1575
REV. 18	1574200	1575
REV. 19	1574200	1575
REV. 20	1574200	1575

REV. 01	1574200	1575
REV. 02	1574200	1575
REV. 03	1574200	1575
REV. 04	1574200	1575
REV. 05	1574200	1575
REV. 06	1574200	1575
REV. 07	1574200	1575
REV. 08	1574200	1575
REV. 09	1574200	1575
REV. 10	1574200	1575
REV. 11	1574200	1575
REV. 12	1574200	1575
REV. 13	1574200	1575
REV. 14	1574200	1575
REV. 15	1574200	1575
REV. 16	1574200	1575
REV. 17	1574200	1575
REV. 18	1574200	1575
REV. 19	1574200	1575
REV. 20	1574200	1575

FORGED BRASS ANGLE & INLINE BELLOWS SEALED HIGH VACUUM VALVES

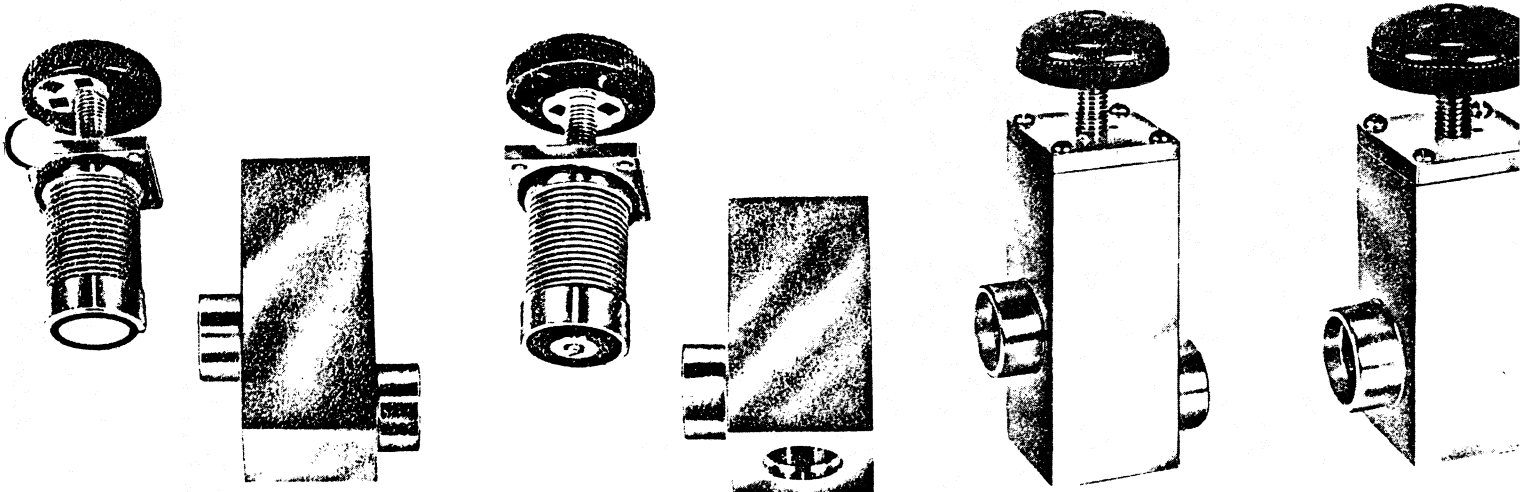

FEATURES:

- Body of one piece high density forging, assures valves to be free of porosity, and virtual leakage.
- Sealing choice of "O" ring seat seal or flat disc seal of low vapor pressure "viton-A", optional.
- Flat disc valves can be supplied with teflon or KEL-F seals at extra cost.
- Full unobstructed port openings permit fast pumpdown.
- Connections: choice of solder or pipe thread.
- All valves leak tested and guaranteed leak tight to helium leak detector having sensitivity to 5×10^{-13} std. cc per sec.



VACUUM ACCESSORIES CORP.
OF AMERICA

390 Central Avenue
Bohemia, L.I., N.Y. 11716
Area Code 516-589-6464

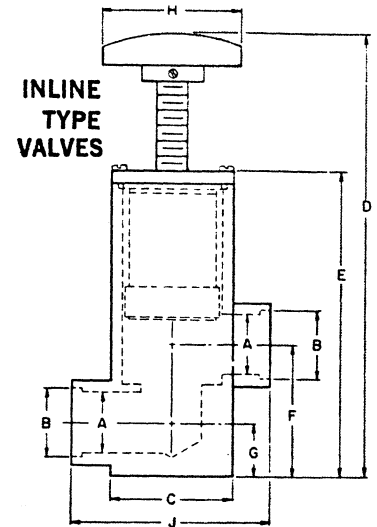
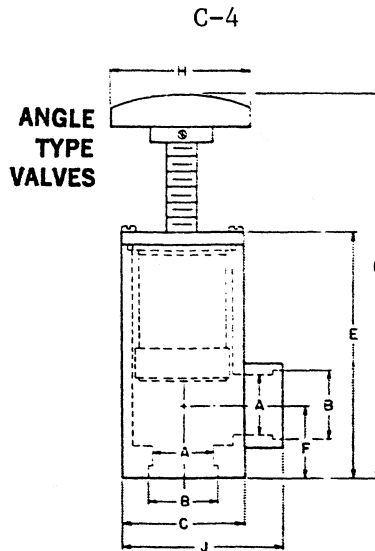

ANGLE TYPE VALVES — MODELS "AT-P" DENOTE PIPE THREAD — MODELS "AT-S" DENOTE SWEAT FITTINGS

Catalog No.	"A" Port. Dia.	Tube O.D.	B Pipe Thread	C Square Stock	D Open	E	F	G	H	J	Stroke
ATP-38	3/8"		1/8" NPT	1"	4-1/8"	2-3/4"	23/32"		1-1/8"	1-3/8"	3/8"
ATS-38	3/8"	3/8"		1"	4-1/8"	2-3/4"	23/32"		1-1/8"	1-3/8"	3/8"
ATS-50	3/8"	1/2"		1"	4-1/8"	2-3/4"	23/32"		1-1/8"	1-3/8"	3/8"
ATP-62	5/8"		1/2" NPT	1-3/8"	5"	3-3/8"	27/32"		1-5/8"	1-15/16"	5/8"
ATS-62	5/8"	3/4"		1-3/8"	5"	3-3/8"	27/32"		1-5/8"	1-15/16"	5/8"
ATP-100	1"		1" NPT	2"	6-3/8"	4"	1-3/16"		2-1/4"	2-5/8"	15/16"
ATS-100	1"	1-1/8"		2"	6-3/8"	4"	1-3/16"		2-1/4"	2-5/8"	15/16"
ATP-150	1-1/2"		1-1/2" NPT	2-1/2"	7-1/2"	4-5/8"	1-5/8"		2-3/4"	3-1/8"	1-3/8"
ATS-150	1-1/2"	1-5/8"		2-1/2"	7-1/2"	4-5/8"	1-5/8"		2-3/4"	3-1/8"	1-3/8"
ATS-200	2"	2-1/8"		3" Round	8-1/4"	5-1/4"	2"		2-3/4"	3-5/8"	1-5/8"

INLINE TYPE VALVES — MODEL "IL"

Catalog No.	"A" Port. Dia.	Tube O.D.	B Pipe Thread	C Square Stock	D Open	E	F	G	H	J	Stroke
ILP-38	3/8"		1/8" NPT	1"	4-1/2"	3-1/8"	1-1/16"	7/16"	1-1/8"	1-3/4"	3/8"
ILS-38	3/8"	3/8"		1"	4-1/2"	3-1/8"	1-1/16"	7/16"	1-1/8"	1-3/4"	3/8"
ILS-50	3/8"	1/2"		1"	4-1/2"	3-1/8"	1-1/16"	7/16"	1-1/8"	1-3/4"	3/8"
ILP-62	5/8"		1/2" NPT	1-3/8"	5-3/4"	4"	1-15/32"	5/8"	1-5/8"	2-1/2"	5/8"
ILS-62	5/8"	3/4"		1-3/8"	5-3/4"	4"	1-15/32"	5/8"	1-5/8"	2-1/2"	5/8"
ILP-100	1"		1" NPT	2"	7-1/4"	5"	2-5/32"	7/8"	2-1/4"	3-1/4"	15/16"
ILS-100	1"	1-1/8"		2"	7-1/4"	5"	2-5/32"	7/8"	2-1/4"	3-1/4"	15/16"
ILS-150	1-1/2"	1-5/8"		2-1/2"	9-3/4"	6-1/4"	3-1/8"	1-3/8"	2-3/4"	3-3/4"	1-3/8"

VACUUM ACCESSORIES CORP. OF AMERICA

390 CENTRAL AVE - P.O. BOX 160
 BOHEMIA, N.Y. 11716
 Phone (516) 589-6464



PRICE SCHEDULE

ANGLE TYPE FORGED BELLOWS SEALED BRASS
 HIGH VACUUM VALVES,
 VITON-A-"O" RING SEAL SEAT & BONNET TYPE = PREFIX "FO"
 VITON-A-FLAT-DISC SEAL SEAT & "O" RING BONNET SEAL = "FD"

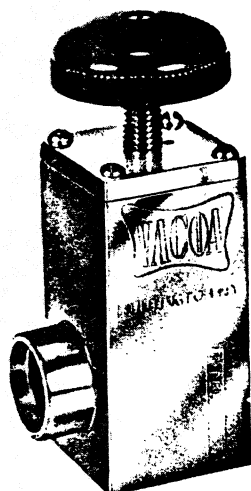

"O" RING SEAL MODEL	"O" RING MODEL PRICE	"DISC-TYPE" SEAL MODEL	FLAT DISC MODEL PRICE
FO-ATP-38	80.00	FD-ATP-38	75.00
FO-ATS-38	80.00	FD-ATS-38	75.00
FO-ATS-50	80.00	FD-ATS-50	75.00
FO-ATP-62	90.00	FD-ATP-62	85.00
FO-ATS-62	90.00	FD-ATS-62	85.00
FO-ATP-100	120.00	FD-ATP-100	115.00
FO-ATS-100	120.00	FD-ATS-100	115.00
FO-ATP-150	150.00	FD-ATP-150	145.00
FO-ATS-150	150.00	FD-ATS-150	145.00
FO-ATS-200	250.00	FD-ATS-200	245.00

INLINE TYPE FORGED BELLOWS SEALED BRASS HIGH
 VACUUM VALVES TYPE "FO" AND TYPE "FD"

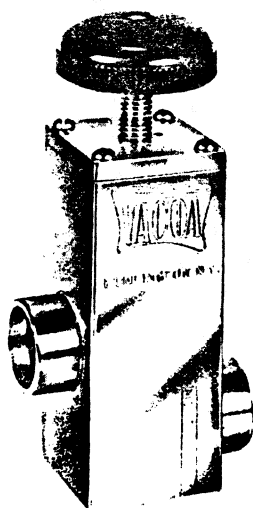

"O" RING SEAL MODEL	"O" RING MODEL PRICE	"DISC-TYPE" SEAL MODEL	FLAT DISC MODEL PRICE
FO-ILP-38	87.00	FD-ILP-38	79.00
FO-ILS-38	87.00	FD-ILS-38	79.00
FO-ILS-50	87.00	FD-ILS-50	79.00
FO-ILP-62	98.00	FD-ILP-62	95.00
FO-ILS-62	98.00	FD-ILS-62	95.00
FO-ILP-100	135.00	FD-ILP-100	125.00
FO-ILS-100	135.00	FD-ILS-100	125.00
FO-ILS-150	160.00	FD-ILS-150	150.00

275 4/8

REPLACEMENT BELLOWS ASSEMBLIES: TO FIT "O" RING SERIES VALVES:		PRICE
MODEL #BO-38	FITS 1" SQUARE VALVES	62.00
MODEL #BO-62	FITS 1½" SQUARE VALVES	70.00
MODEL #BO-100	FITS 2" SQUARE VALVES	90.00
MODEL #BO-150	FITS 2½" SQUARE VALVES	98.00
MODEL #BO-200	FITS 3" ROUND VALVES	190.00

TO FIT "FLAT-DISC" SERIES VALVES:		PRICE
MODEL #BD-38	FITS 1" SQUARE VALVES	55.00
MODEL #BD-62	FITS 1½" SQUARE VALVES	65.00
MODEL #BD-100	FITS 2" SQUARE VALVES	85.00
MODEL #BD-150	FITS 2½" SQUARE VALVES	95.00
MODEL #BD-200	FITS 3" ROUND VALVES	185.00

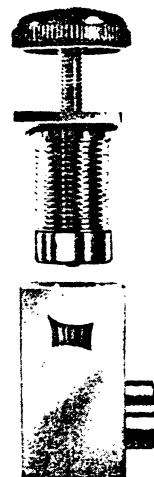

REPLACEMENT BONNET "O" RINGS AND SEAT SEALS: FOR FLAT DISC SERIES			
	VITON	TEFLON	KEL-F
SIZES UNDER 1"	25.00	40.00	50.00
1" Valves	30.00	40.00	50.00
1½" Valves	35.00	50.00	75.00
2" Valves	40.00	60.00	75.00

SET OF VITON "O" RINGS FOR "O" RING SERIES VALVES:	
SIZES UNDER 1"	30.00
1" Valves	30.00
1½" Valves	35.00
2" Valves	45.00

reference tube A QUICK CALIBRATION DEVICE FOR HASTINGS VACUUM GAUGES

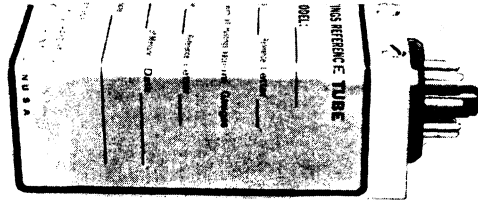

The Hastings Reference Tube is an evacuated, sealed vacuum gauge tube accurately calibrated and marked at its exact pressure. It is electrically equivalent to our metal and Pyrex gauge tubes. It permits quick and easy recalibration of Hastings Vacuum Gauges by merely plugging the instrument into the reference and adjusting the calibration potentiometer until the instrument reads the exact pressure noted on the reference tube.

Equivalent Gauge Tube and Range			Reference Tube Model No.
Metal	Pyrex	Range	
DV-4D	DV-16D	0-20 mm Hg	DB-16D
*DV-5M	*DV-18	0-100 Microns Hg	*DB-18
DV-6M	DV-20	0-1000 Microns Hg	DB-20
DV-8M	DV-31	.01-10 Microns Hg	DB-31
DV-23	—	0-5000 Microns Hg	DB-33
DV-24	—	0-50 Torr	DB-44
DV-100	—	0-100 Torr	Not Available
DV-77	—	10 ⁻⁶ to 10 ⁻² Torr	Not available
DV-100	—	0-100 Torr	Not available
DV-800	—	0-800 Torr	Not available

*State reference letter of your Gauge Tube type for matching purposes.

ADVANTAGES OF HASTINGS VACUUM INSTRUMENTS

- Fully compensated for both temperature and rate-of-change of temperature
- Designed for panel mounting or in instrument cabinets.

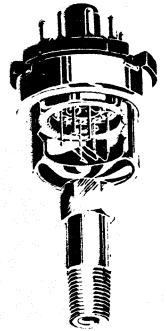

Hastings instruments have many exclusive advantages. Self contained, solid-state circuitry throughout assures long life and low maintenance costs. All instruments use frictionless, taut-band pivotless meters. Instruments are electrical to provide rapid response and permit remote installations.

Hastings gauge tubes can withstand great g-shock and vibration, using short firmly connected thermocouples with no suspended weld to an external heater. They are corrosion resistant and non-contaminating using noble metal thermopiles which assures stable calibration held indefinitely. Gauge tubes are easily cleaned with any suitable solvent. Each gauge tube is specifically designed and checked out for the range it covers, assuring maximum sensitivity.

gauge tubes

THE ONLY GAUGE TUBES COMPENSATED FOR BOTH AMBIENT TEMPERATURE AND RATE OF TEMPERATURE CHANGE

- **METAL** Constructed of nickel plated steel with plastic bases color coded to prevent mix-up.
- **PYREX GLASS** Available for high temperature and bakeable systems.
- **"R" SERIES** Ruggedized with a gold-plated hermetic seal base with monel housing for weather resistance.
- **STAINLESS STEEL** For weather-proof, corrosive and bakable applications. Withstands high over-pressurization. May be brazed or welded to system. Plain or threaded connection.

FOR PROPER ACCURACY AND PERFORMANCE, HASTINGS VACUUM GAUGES SHOULD ALWAYS BE USED WITH THE PROPER RANGE OF HASTINGS VACUUM GAUGE TUBES!

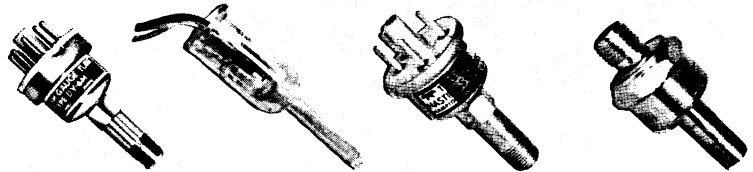

INSTRUMENT SERIES	RANGE	METAL TYPE	BASE COLOR	PYREX TYPE	"R" SERIES TYPE	STAINLESS STEEL TYPE
NV-8	10 ⁻⁵ torr 10 ⁻² torr	DV-8	Green	DV-31	—	—
VT-5, CVT-15/25	0-100 μ Hg	DV-5M	Red	DV-18	—	—
VT-6, CVT-16/26, DAV-6, TV-4A, MRV-6, TV-47	0-1000 μ Hg	DV-6M	Yellow	DV-20	DV-6R	DV-36
VH-3, CVH-3/23	0-5 torr	DV-23	Orange	—	—	—
VT-4, CVT-14/24, DAV-4, TP-7A, MRV-4, TV-47	0-20 mm Hg	DV-4D	Purple	DV-16D	DV-4R	DV-34
VH-4, CVH-4/24	0-50 torr	DV-24	White	—	—	—
NV-100	0-100 torr	DV-100	Brown	—	—	—

MODEL DV-800 GAUGE TUBE is used with Wide Range Vacuum Gauges, Models NV-800 and DNNV-800. This linear voltage displacement transformer type is for the range of 0-800 torr.



MODEL DV-77 GAUGE TUBE is used with the Cold Cathode Ion Gauge, Model NV-77. Range is 10⁻⁶ to 10⁻² torr. Replacement cathode-anode assemblies are available.



TEMPERATURE SENSORS

DIODE TEMPERATURE SENSORS

Silicon Diode Temperature Sensors

Series DT-470

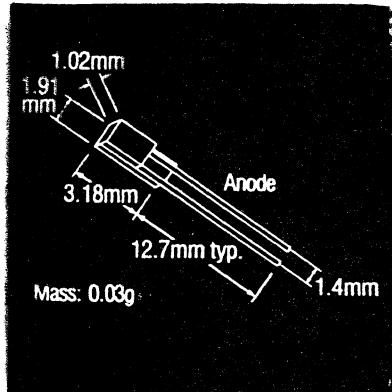

*Wide Range, Stable, Precise and Repeatable—
The DT-470 Series Device is the First Mass-Produced
Interchangeable Cryogenic Temperature Sensor*

- › Monotonic temperature response over its useful range from 1.4K to 475K
- › High sensitivity for critical, low temperature measurement
- › All sensors follow a standard temperature calibration curve (10)
- › Available in four bands of tracking accuracy to allow selection dependent upon application
- › Repeatability at 4.2K: Typically ± 10 mK over repeated thermal cycling
- › Sensors provided with a variety of mounting adapters including probe assemblies—
See DT-470 Technical Bulletin

Model	Band	2K-100K	100K-305K	305K-475K
DT-470-SD-11	11	$\pm 0.25K$	$\pm 0.5K$	$\pm 1.0K$
DT-470-SD-12	12	$\pm 0.5K$	$\pm 1.0K$	$\pm 2.0K$
DT-470-SD-12A	12A	$\pm 0.5K$	$\pm 1\%$ of Temp.	$\pm 1\%$ of Temp.
DT-470-SD-13	13	$\pm 1.0K$	$\pm 1\%$ of Temp.	$\pm 1\%$ of Temp.

(Not recommended for use in magnetic fields)

Series DT-471

An Economical Diode for Applications Where Temperature Measurements Below 10K are Not Required





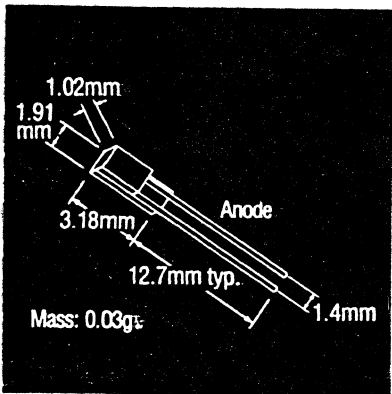

- › Temperature range: 10K to 425K (325K with any mounting adaptor)
- Standard response curve: Curve 10 truncated at 10K and 425K
- › Accuracy: $\pm 1.5K$ or $\pm 1\%$ of temperature reading (K), whichever is greater
- › Package configurations identical to DT-470 Series
- › Two types of calibrations offered:
Type 10L (10K-325K) and Type 10M (10K-425K)

Model

DT-471-SD
DT-471-SD-10L
DT-471-SD-10M

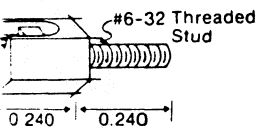
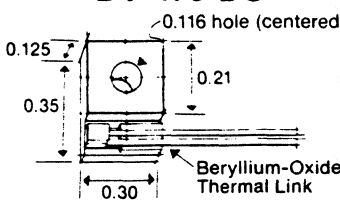
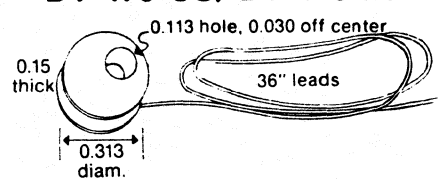

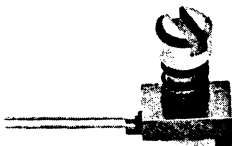
For more detailed specifications on any Lake Shore products, return the response card on the back cover or call (614) 891-2243.

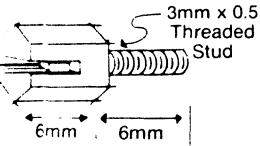
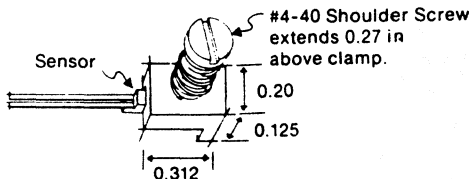
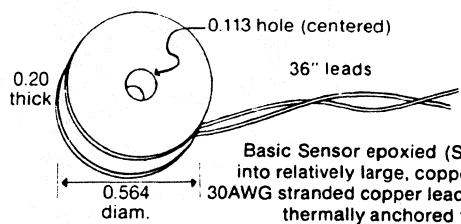
		
<p>DT-470-ET</p>  <p>or soldered onto SAE-threaded copper adapter. Temperature Range: 1.4K to 325K. Mass: 1.4g</p>	<p>DT-470-BO</p>  <p>Basic Sensor soldered onto bolt-on copper block with leads thermally anchored to block. Temperature Range: 1.4K to 325K. Mass: 1.5g</p>	<p>DT-470-CU/DT-470-DI</p>  <p>Basic Sensor mounted into bolt-on disk with leads thermally anchored to disk with Stycast epoxy. CU version is 4-leaded, DI is 2-leaded. Temperature Range: 1.4K to 325K. Mass (excl leads): 1.0g</p>
		
<p>DT-470-MT</p>  <p>soldered into metric-threaded copper adapter. Temperature Range: 1.4K to 325K. Mass: 1.4g</p>	<p>DT-470-CO</p>  <p>Basic Sensor with spring-loaded brass clamp to hold Sensor to sample. Temperature Range: 1.4K to 475K. Mass (w/o Sensor): 1.7g</p>	<p>DT-470-CY</p>  <p>Basic Sensor epoxied (Stycast) into relatively large, copper disk. 30AWG stranded copper lead pair is thermally anchored to disk. Temperature Range: 1.4K to 325K. Mass (excl leads): 4.3g</p>

Temperature Sensors

Accuracy, Interchangeability: Sensors track above Standard Interchangeability Curve (Curve #10) within the tolerance bands:

Curve/Band (Suffix)	Accuracy (Tolerance)		
	2K-100K	100K-305K	305K-475K
11	±0.25K	±0.5K	±1.0K
12	±0.5K	±1.0K	±2.0K
12A	±0.5K	±1% of Temp.	±1% of Temp.
13	±1.0K	±1% of Temp.	±1% of Temp.

Temperature Offset, Vacuum-to-Liquid at 4.2K*: Typically 5 to 35 millikelvin depending on configuration.

Magnetic Field Use: Not recommended.

Maximum Recommended Storage Temperature: 60°C

Maximum Installation Temperature: DT-470-SD or DT-470-CC 200°C. Other configurations: 60°C.

Construction, Materials:

DT-470-SD: Sapphire base with alumina body and lid. Molybdenum/manganese metallization on base bottom and lid top with nickel and gold plating. Gold-tin solder as lid seal. Hermeticity: Less than 1×10^{-8} std cc/sec. Cavity size: less than 1mm^3 . See lead specifications below.

Leads: Gold-plated Kovar, uninsulated. 0.015in X 0.004in cross-section X approx. 0.5in long. Designed to withstand at least five right angle bends. Polarity: Positive lead on right with package lid up and leads toward user.

Configuration Adapters: Gold-plated OFHC copper except for CO adapter which is brass with steel spring.

* Contact factory for test method and details if required.



Lake Shore Cryotronics, Inc.

64 E. Walnut St., Westerville, Ohio 43081.
 (614) 891-2243 • Telex: 24-5415 • Cryotron WTVL

Technical Data STANDARD CURVE #10

STANDARD CURVE #10 Measurement Current = 10 μ A \pm 0.05%

T (K)	Voltage	dV/dT (mV/K)	T (K)	Voltage	dV/dT (mV/K)	T (K)	Voltage	dV/dT (mV/K)
1.40	1.69812	-13.1	16.0	1.28527	-18.6	95.0	0.98564	-2.02
1.60	1.69521	-15.9	16.5	1.27607	-18.2	100.	0.97550	-2.04
1.80	1.69177	-18.4	17.0	1.26702	-18.0	110.	0.95487	-2.08
2.00	1.68786	-20.7	17.5	1.25810	-17.7	120.	0.93383	-2.12
2.20	1.68352	-22.7	18.0	1.24928	-17.6	130.	0.91243	-2.16
2.40	1.67880	-24.4	18.5	1.24053	-17.4	140.	0.89072	-2.19
2.60	1.67376	-25.9	19.0	1.23184	-17.4	150.	0.86873	-2.21
2.80	1.66845	-27.1	19.5	1.22314	-17.4	160.	0.84650	-2.24
3.00	1.66292	-28.1	20.0	1.21440	-17.6	170.	0.82404	-2.26
3.20	1.65721	-29.0	21.0	1.19645	-18.5	180.	0.80138	-2.28
3.40	1.65134	-29.8	22.0	1.17705	-20.6	190.	0.77855	-2.29
3.60	1.64529	-30.7	23.0	1.15558	-21.7	200.	0.75554	-2.31
3.80	1.63905	-31.6	24.0	1.13598	-15.9	210.	0.73238	-2.32
4.00	1.63263	-32.7	25.0	1.12463	-7.72	220.	0.70908	-2.34
4.20	1.62602	-33.6	26.0	1.11896	-4.34	230.	0.68564	-2.35
4.40	1.61920	-34.6	27.0	1.11517	-3.34	240.	0.66208	-2.36
4.60	1.61220	-35.4	28.0	1.11212	-2.82	250.	0.63841	-2.37
4.80	1.60506	-36.0	29.0	1.10945	-2.53	260.	0.61465	-2.38
5.00	1.59782	-36.5	30.0	1.10702	-2.34	270.	0.59080	-2.39
5.50	1.57928	-37.6	32.0	1.10263	-2.08	280.	0.56690	-2.39
6.00	1.56027	-38.4	34.0	1.09864	-1.92	290.	0.54294	-2.40
6.50	1.54097	-38.7	36.0	1.09490	-1.83	300.	0.51892	-2.40
7.00	1.52166	-38.4	38.0	1.09131	-1.77	310.	0.49484	-2.41
7.50	1.50272	-37.3	40.0	1.08781	-1.74	320.	0.47069	-2.42
8.00	1.48443	-35.8	42.0	1.08436	-1.72	330.	0.44647	-2.42
8.50	1.46700	-34.0	44.0	1.08093	-1.72	340.	0.42221	-2.43
9.00	1.45048	-32.1	46.0	1.07748	-1.73	350.	0.39783	-2.44
9.50	1.43488	-30.3	48.0	1.07402	-1.74	360.	0.37337	-2.45
10.0	1.42013	-28.7	50.0	1.07053	-1.75	370.	0.34881	-2.46
10.5	1.40615	-27.2	52.0	1.06700	-1.77	380.	0.32416	-2.47
11.0	1.39287	-25.9	54.0	1.06346	-1.78	390.	0.29941	-2.48
11.5	1.38021	-24.8	56.0	1.05988	-1.79	400.	0.27456	-2.49
12.0	1.36809	-23.7	58.0	1.05629	-1.80	410.	0.24963	-2.50
12.5	1.35647	-22.8	60.0	1.05267	-1.81	420.	0.22463	-2.50
13.0	1.34530	-21.9	65.0	1.04353	-1.84	430.	0.19961	-2.50
13.5	1.33453	-21.2	70.0	1.03425	-1.87	440.	0.17464	-2.49
14.0	1.32412	-20.5	75.0	1.02482	-1.91	450.	0.14985	-2.46
14.5	1.31403	-19.9	80.0	1.01525	-1.93	460.	0.12547	-2.41
15.0	1.30422	-19.4	85.0	1.00552	-1.96	470.	0.10191	-2.30
15.5	1.29464	-18.9	90.0	0.99565	-1.99	475.	0.09062	-2.22

Conformance to Standard Curve #10

Sample Model Number	Curve/Band (Suffix)	Accuracy (\pm K)		
		2K-100K	100K-305K	305K-475K
DT-470-SD-11	11	0.25	0.5	1
	12	0.5	1	2
	12A	0.5	1% of T	1% of T
	13	1	1% of T	1% of T



STANDARD RECTANGULAR WAVEGUIDE- TO-COAXIAL ADAPTERS

40 SERIES

DATA SHEET

No. T6D

- LOWEST VSWR, 1.02 TYPICAL
- LOW INSERTION LOSS
- COMPLETE LINE 1.0 - 40.0 GHz

DESCRIPTION

The 40 Series Adapters allow transmission of power in either direction with very low reflection. This is achieved by the use of a broadband matching structure. VSWR over the full band is 1.02 typical (1.04 Max.) for most models, or that of the coaxial connector used.

Custom designs for fractional and broad band, in-line, half height or other specials are available. Assemblies are furnished with an aluminum housing. Finish is chromate conversion per MIL-C-5541, Class 3, painted with gray epoxy enamel.

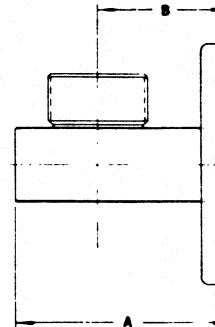
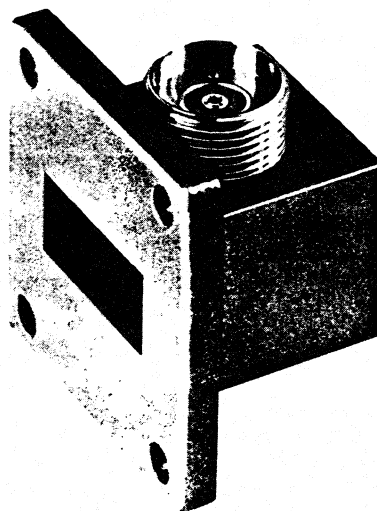

SPECIFICATIONS

MODEL NO.	FREQUENCY RANGE (GHz)	WAVEGUIDE SIZE	EQUIVALENT FLANGE	DIMENSIONS (IN.)	
				A MAX.	B ±.03
STANDARD ADAPTERS					
E40	1.0 - 1.45	WR-770	WR-770	5.50	3.44
L40	1.12 - 1.70	WR-650	UG-418B/U	4.50	3.06
LM40	1.45 - 2.20	WR-510	UG-1717/U	4.80	3.27
LA40	1.70 - 2.60	WR-430	UG-437B/U	3.70	2.62
LS40	2.20 - 3.30	WR-340	UG-554A/U	2.65	1.62
S40	2.60 - 3.95	WR-284	UG-584/U	2.75	1.75
B40	3.30 - 4.90	WR-229	CMR-229	2.00	1.32
G40	3.95 - 5.85	WR-187	UG-407/U	2.00	1.31
D40	4.90 - 7.05	WR-159	CMR-159	1.75	1.26
J40	5.85 - 8.20	WR-137	UG-441/U	1.50†	1.04
H40	7.05 - 10.0	WR-112	UG-138/U	1.44	.80
W40	7.0 - 11.0	WR-102	M3922/70-002	1.25	.63
X40	8.2 - 12.4	WR-90	UG-135/U	1.20	.63
M40*	10.0 - 15.0	WR-75	M3922/53-008	1.15	.63
P40*	12.4 - 18.0	WR-62	UG-1665/U	1.20	.68
N40+	15.0 - 22.0	WR-51	M3922/70-011	1.10	.75
K40+□	18.0 - 26.5	WR-42	UG-597/U	.90	.45††
Y40□	22.0 - 33.0	WR-34	UG-1530/U ^Δ	.90	.45
A40□	26.5 - 40.0	WR-28	UG-599/U ^Δ	.90	.60

* TNC VSWR ≤ 1.1 to 16GHz

+ SMA VSWR ≤ 1.01 + .005 f(GHz) to 26GHz

† 1.62 for - 14

Δ Aluminum

□ SSMA VSWR ≤ 1.09 + .007 f(GHz) to 36 GHz

†† .47 for - 17

ORDERING INFORMATION

Add suffixes to model number as follows:

- (1) For Connector type: -17 for SSMA female -3 for SMA female -T for TNC female
 -17M for SSMA male -3M for SMA male -TM for TNC male
 -N for type N female -7 for precision 7 mm
 -NM for type N male -14 for GR type 900

- (2) For VSWR Maximum: A for 1.04 B for 1.06 C for 1.10

- (3) For Fractional bandwidth: L for lower half M for middle half H for upper half

EXAMPLE: Model X40-7AL=WR90 to 7 mm coaxial adapter with VSWR of 1.02 over the frequency range 8.2 - 10.0 GHz.

Data subject to change without notice.

mrc

MICROWAVE RESEARCH CORPORATION

SERIES 8016 RECTANGULAR CONNECTOR

20 CONTACTS

MALE PLUG* (Exposed Contacts)

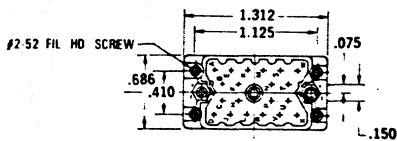
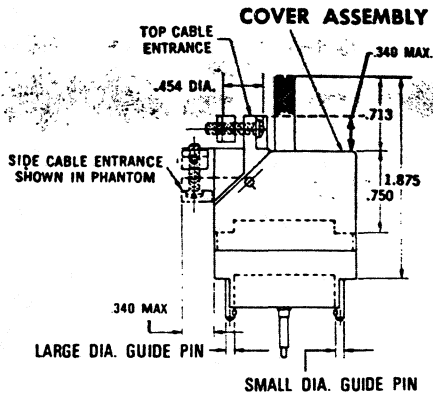

38 CONTACTS

MALE PLUG* (Exposed Contacts)

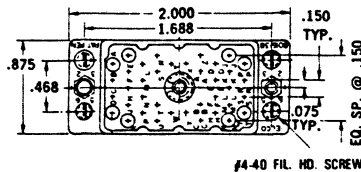
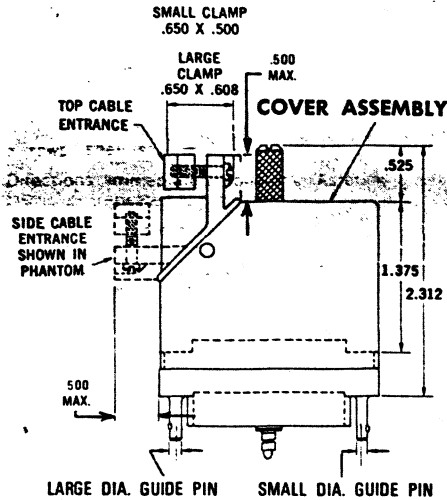

56 CONTACTS

MALE PLUG* (Exposed Contacts)

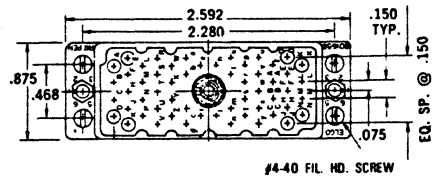
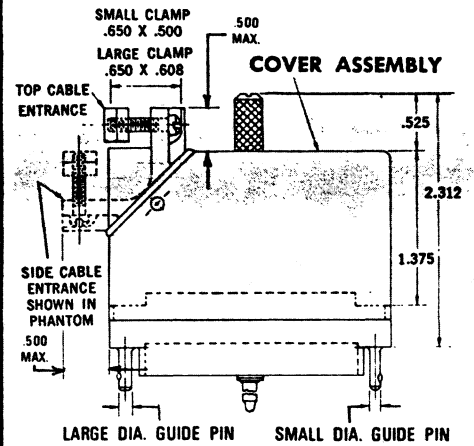

FEMALE RECEPTACLE* (Recessed Contacts)

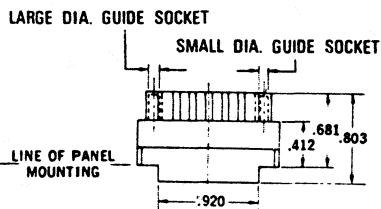
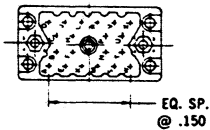

FEMALE RECEPTACLE* (Recessed Contacts)

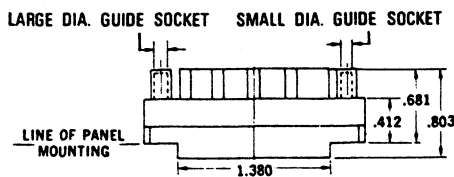
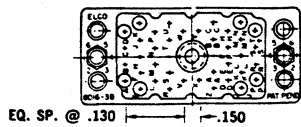

FEMALE RECEPTACLE* (Recessed Contacts)

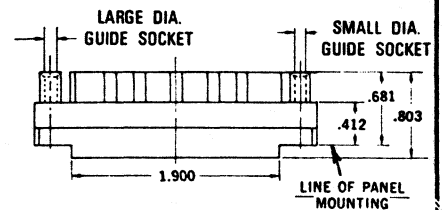
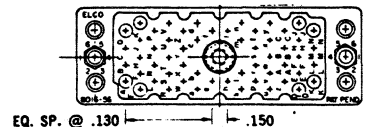

RECOMMENDED CHASSIS LAYOUT

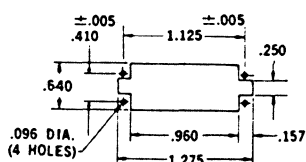

RECOMMENDED CHASSIS LAYOUT LAYOUT FOR FRONT CHASSIS MOUNTING

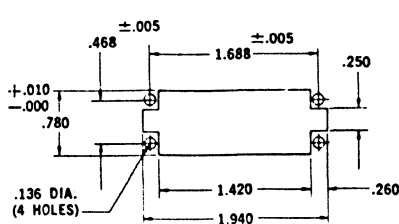

RECOMMENDED CHASSIS LAYOUT

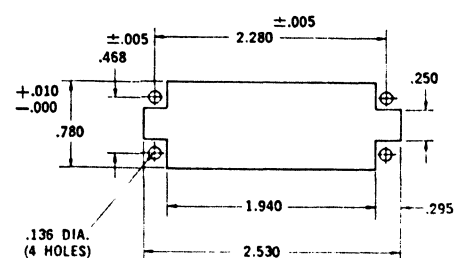

126 series miniature hexagonal connectors

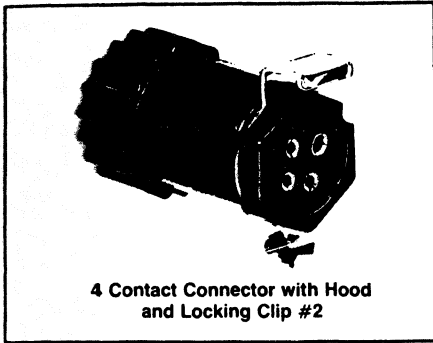

4 Contact Connector with Hood and Locking Clip #2



Connector Pair (any number of Contacts) with Hex Nuts

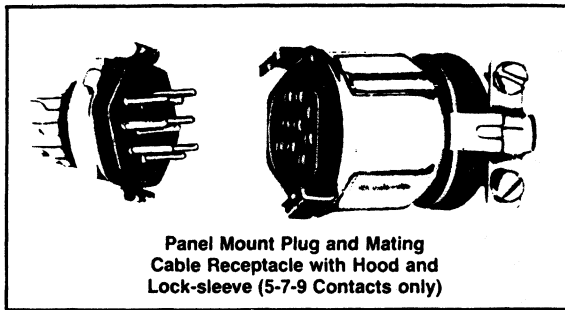

Panel Mount Plug and Mating Cable Receptacle with Hood and Lock-sleeve (5-7-9 Contacts only)

Amphenol miniature hexagonal connectors are available in four contact configurations with a variety of accessories to meet a wide range of applications.

The connectors can be used for rack and panel, cable to cable, and cable to panel connections.

Locking clips are available to prevent unmating caused by vibration or shock.

Dimensions

Overall Diameter – $\frac{3}{4}$ "

Mated – $1\frac{1}{64}$ " (extended length to the back of the cable clamp)

Specifications

Dielectric – male connectors – glass-filled diallyl phthalate
female connectors – 4 contact-diallyl phthalate

5, 7, 9 contacts – nylon

Contact size – #20 (except one #16 on 4 contact insert)

Wire size – #20 or smaller

Temperature range – -60°C to $+125^{\circ}\text{C}$
(-76°F to $+257^{\circ}\text{F}$)

Current rating – 7.5 amps

Voltage rating – 500 VAC (RMS) at Sea Level

Hardware – cold rolled steel, nickel plated

Contacts – copper alloy, gold over copper plate

Panel thickness – $\frac{3}{32}$ " (max)

Mounting Holes

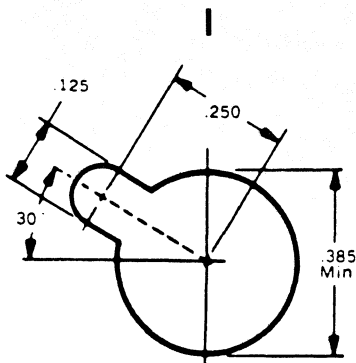

Four-Contact
126-214, 126-214-1001,
126-233, 126-215-1002 only

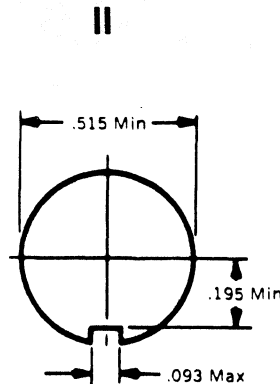

5-7-9 Contact
Hex Nut Type Without
Panel Locking Clip

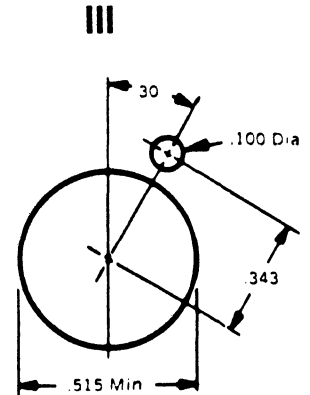

5-7-9 Contact
Hex Nut Type With
Panel Locking Clip

Amphenol® miniature hexagonal connectors

126 series connector assemblies

4-Contact

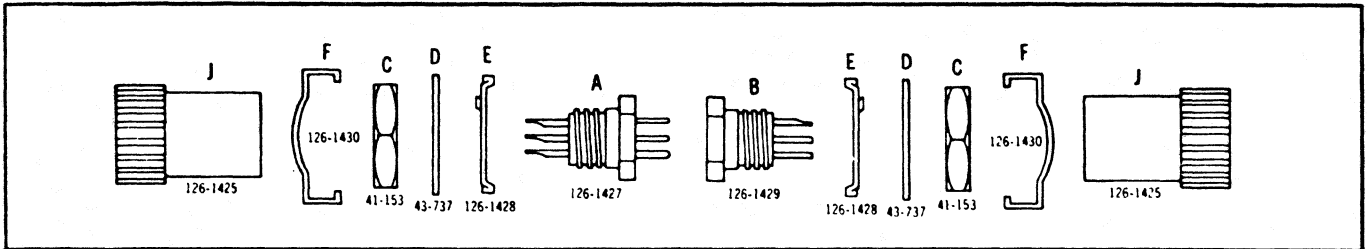

5-7-9 Contact Connectors

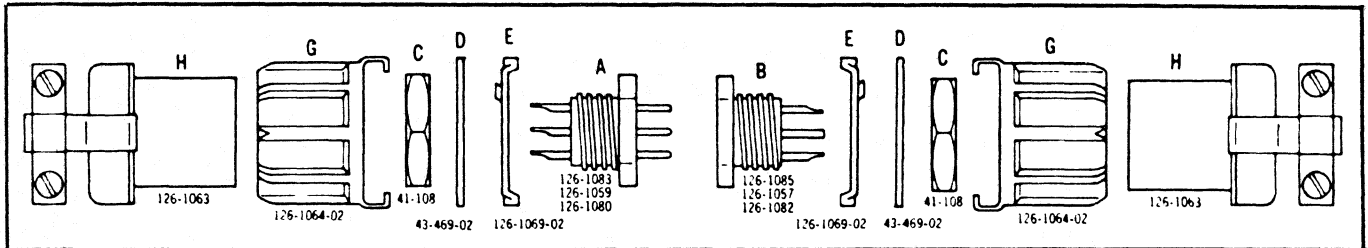

order information

These connectors can be ordered in any combination to suit your needs. Please refer to the exploded view drawing above to determine the components you require. Note the identification letter. Then order by the Amphenol part

number indicated along side the desired combination of components and the required number of contacts. For example, a male 5 contact connector with rear hood & cable clamp and lock sleeve requires components A, G and H. In the column for male 5 contact

assemblies, AGH indicates part number 126-217. If you order part #126-217, you will automatically receive all three components. They may also be ordered individually, if you prefer. Simply refer to the individual component part numbers shown below.

connector assemblies

4-Contact

Key	MALE Part No.	Mtg.	Key	FEMALE Part No.	Mtg.
A	126-1427	—	B	126-1429	—
AC	126-1431	—	BC	126-3815	—
ACD	126-1432	—	BCD	126-3816	—
AFJ	126-214-1000	—	BFJ	126-215	—
ACE	126-214	I	BCE	126-233	I
ACDE	126-214-1001	I	BCDE	126-215-1002	I
AEJ	126-214-1002	—	BEJ	126-215-1001	—

Backshells do not have cable clamps.

5-Contact

Key	MALE Part No.	Mtg.	Key	FEMALE Part No.	Mtg.
A	126-1083	—	B	126-1085	—
AC	126-0101	II	BC	126-011	II
ACD	126-010-1000	II	BCD	126-011-1000	II
AGH	126-217	—	BGH	126-223	—
ACE	126-216	III	BCE	126-218	III
ACDE	126-216-1000	III	BCDE	126-218-1000	III
AEH	126-217-1000	—	BEH	126-223-1000	—

Amphenol® miniature hexagonal connectors

126 series connector assemblies (cont.) parts

4-Contact Connector

Description	Part No.	Item Key
Basic Male Connector	126-1427	A
Basic Female Connector	126-1429	B
Hex Nut	41-153	C
Lockwasher	43-737	D
Clip #1	126-1428	E
Clip #2	126-1430	F
Hood	126-1425	J

7-Contact

Key	MALE Part No.	Mtg.	Key	FEMALE Part No.	Mtg.
A	126-1059	—	B	126-1057	—
AC	126-191	II	BC	126-192	II
ACD	126-191-1000	II	BCD	126-192-1001	II
AGH	126-195	—	BGH	126-196	—
ACE	126-197	III	BCE	126-198	III
ACDE	126-197-1000	III	BCDE	126-198-1003	III
AEH	126-195-1002	—	BEH	126-196-1000	—

9-Contact

Key	MALE Part No.	Mtg.	Key	FEMALE Part No.	Mtg.
A	126-1080	—	B	126-1082	—
AC	126-012	II	BC	126-013	II
ACD	126-012-1000	II	BCD	126-013-1000	II
AGH	126-220	—	BGH	126-222	—
ACE	126-219	III	BCE	126-221	III
ACDE	126-219-1000	III	BCDE	126-221-1000	III
AEH	126-220-1000	—	BEH	126-221-1001	—

5-7-9-Contact Connectors

Description	Part No.	Item Key
5-contact Basic Male Connector	126-1083	A
5-contact Basic Female Connector	126-1085	B
7-contact Basic Male Connector	126-1059	A
7-contact Basic Female Connector	126-1057	B
9-contact Basic Male Connector	126-1080	A
9-contact Basic Female Connector	126-1082	B
Hex Nut	41-108	C
Lock washer	43-469-02	D
Clip	126-1069-02	E
Locksleeve	126-1064-02	G
Hood & Cable Clamp	126-1063	H

Edge connectors for 1/16" (1.588 mm) boards

340 (8.64) (1.000) Contact barrier commercial and military (MIL-C-21097) types. Double and single readout—as specified

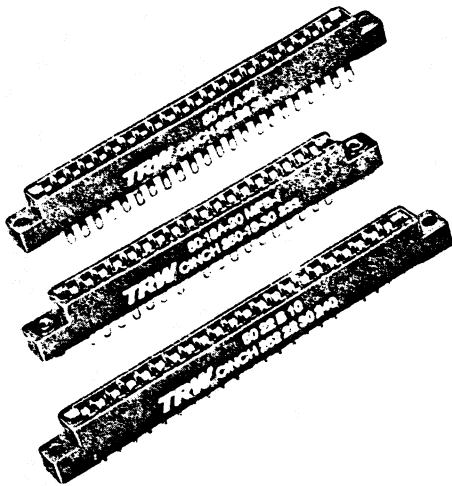

Insulator: Glass fiber filled diallyl phthalate per MIL-M-14 Type SGD-F.
Contact style: Bifurcated bellows.
Contact material:
 1) Commercial type: Phosphor bronze.
 2) Military type: Beryllium copper.
Contact plating:
 1) Commercial type: Stripe plated with .000030" gold in contact area and .000010" gold on tails with copper underplate. No plating on edges.
 2) Military type: .000050" gold over .00010" copper.
Termination: Solder eyelet terminals with .200" (5.08 mm) between row spacing on double readout. Dip solder tails with either .140" (3.56 mm) or .200" (5.08 mm) between row spacing on double readout.

Test voltage: 1800 volts RMS AC at sea level. Rated current: 5 amps.
Polarizing keys: Between contact type Part no. 50-PK-2 or in contact type Part no. 50-PK-1. Order separately.
Card guide: Part no. 50-GP-1. Order separately.
UL recognized

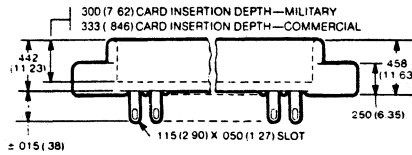

With plain mounting holes

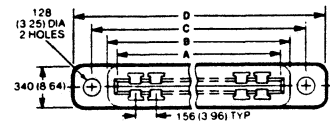

With molded-in bushings (Military)

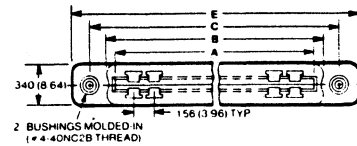

With floating bushings (Military)



Solder Eyelet

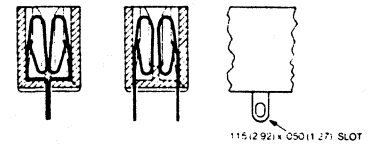

Dip Solder

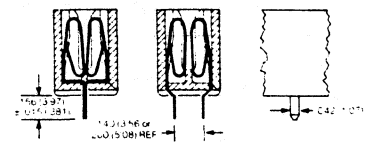

Extended Length Dip Solder

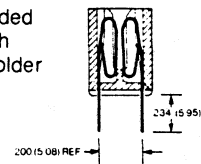

No. of Contact Positions	Dimensions									
	A		B		C		D		E	
	In.	MM	In.	MM	In.	MM	In.	MM	In.	MM
6	1.100	27.94	1.239	31.47	1.531	38.89	1.785	45.34	1.937	49.19
10	1.724	43.79	1.864	47.35	2.156	54.76	2.410	61.21	2.562	65.07
12	2.036	51.71	2.177	55.30	2.469	62.71	2.723	69.16	2.875	73.03
15	2.504	63.60	2.645	67.18	2.937	74.60	3.191	81.05	3.343	84.91
18	2.972	75.49	3.114	79.10	3.406	86.51	3.660	92.96	3.812	96.82
22	3.596	91.34	3.739	94.97	4.031	102.39	4.285	108.84	4.437	112.70
25	4.067	103.30	4.208	106.88	4.500	114.30	4.754	120.75	4.906	124.61

... and single
... is specified

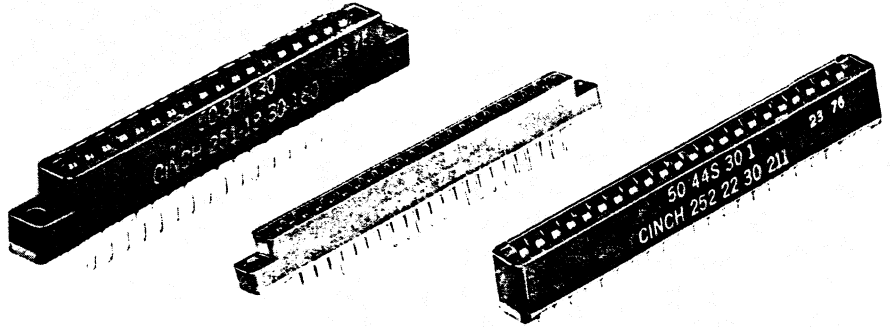
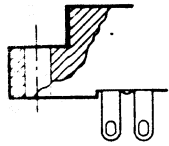

Plain Mounting Hole

Contact Positions	Distributor Part Numbers							
	Single Readout			Double Readout				
	Solder Eyelet	DIP Solder .156" long	DIP Solder .234" long	Solder Eyelet	DIP Solder .125" long	DIP Solder .156" long	DIP Solder .234" long	DIP Solder .234" long
					.140" Between Rows		.200" Between Rows	.200" Between Rows
	Mounting Hole	Mounting Hole	Mounting Hole	Mounting Hole	Mounting Hole	W.O. Mounting Ears	Mounting Hole	Mounting Hole
6	50-6A-20	50-6B-10	50-6S-10	50-12A-30	50-12S-30-2	50-12S-30-1	50-12B-10	50-12S-20
10	50-10A-20	50-10B-10	50-10S-10	50-20A-30	50-20S-30-2	50-20S-30-1	50-20B-10	50-20S-20
12	50-12A-20		50-12S-10	50-24A-30	50-24S-30-2	50-24S-30-1	50-24B-10	50-24S-20
15	50-15A-20	50-15B-10	50-15S-10	50-30A-30	50-30S-30-2	50-30S-30-1	50-30B-10	50-30S-20
18	50-18A-20	50-18B-10	50-18S-10	50-36A-30	50-36S-30-2	50-36S-30-1	50-36B-10	50-36S-20
22	50-22A-20	50-22B-10	50-22S-10	50-44A-30	50-44S-30-2	50-44S-30-1	50-44B-10	50-44S-20
25	50-25A-20	50-25B-10	50-25S-10	50-50A-30	50-50S-30-2	50-50S-30-1	50-50B-10	50-50S-20

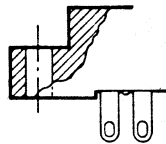

Plain Mounting Hole

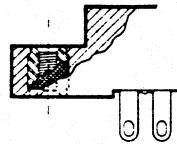

Molded-in Bushing

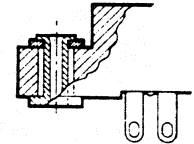

Floating Bushing

Military type per MIL-C-21097 with conventional solder terminals

Single Readout

Contact Positions	Plain Mounting Hole		Molded-in Bushing		Floating Bushing	
	Dist. No.	Military No.	Dist. No.	Military No.	Dist. No.	Military No.
6	50-6A-20M-1	M21097/21-001	50-6A-20-MB-1	M21097/21-004	50-6A-20-MFB-1	M21097/21-007
10	50-10A-20M-1	M21097/21-037	50-10A-20-MB-1	M21097/21-040	50-10A-20-MFB-1	M21097/21-043
15	50-15A-20M-1	M21097/21-073	50-15A-20-MB-1	M21097/21-076	50-15A-20-MFB-1	M21097/21-079
18	50-18A-20M-1	M21097/21-109	50-18A-20-MB-1	M21097/21-112	50-18A-20-MFB-1	M21097/21-115
22	50-22A-20M-1	M21097/21-145	50-22A-20-MB-1	M21097/21-148	50-22A-20-MFB-1	M21097/21-151

Double Readout .200 (5.08 mm) spacing between rows

Contact Positions	Plain Mounting Hole		Molded-in Bushing		Floating Bushing	
	Dist. No.	Military No.	Dist. No.	Military No.	Dist. No.	Military No.
6	50-12A-30M-1	M21097/21-019	50-12A-30-MB-1	M21097/21-022	50-12A-30-MFB-1	M21097/21-025
10	50-20A-30M-1	M21097/21-055	50-20A-30-MB-1	M21097/21-058	50-20A-30-MFB-1	M21097/21-061
15	50-30A-30M-1	M21097/21-091	50-30A-30-MB-1	M21097/21-094	50-30A-30-MFB-1	M21097/21-097
18	50-36A-30M-1	M21097/21-127	50-36A-30-MB-1	M21097/21-130	50-36A-30-MFB-1	M21097/21-133
22	50-44A-30M-1	M21097/21-163	50-44A-30-MB-1	M21097/21-166	50-44A-30-MFB-1	M21097/21-169

Military type per MIL-C-21097 w/dip solder term. Plain mounting hole

Double readout .200 (5.08 mm) spacing between rows.

Contact Positions	Distributor No.	Mil. Part No.
6	50-12B-10M-1	M21097/21-028
10	50-20B-10M-1	M21097/21-064
15	50-30B-10M-1	M21097/21-100
18	50-36B-10M-1	M21097/21-136
22	50-44B-10M-1	M21097/21-172

APPENDIX D

Sensor Card Calibration

**SENSOR CARD CALIBRATION PROCEDURE
LAKESHORE DT-471 SENSOR**

R. Norrod

August 5, 1988

The following procedure is used to calibrate the VLBA* style sensor card temperature monitor circuits for a DT-471 sensor:

1. Plug the sensor card into the calibration box. Check the cal box output voltages, The V_{sens} readings should be:

<u>T</u> (K)	<u>V_{sens} (mV)</u>
300	-518.9
50	-1070.5
18	-1249.3
13	-1345.3

2. Set the DVM switch to I_{SENS} .
3. Set the MODE switch to I_A and adjust the A-10 μA pot for a reading of -1000 mV at the DVM jack.
4. Set DVM switch to TA. Set the MODE switch to T_A/T_B and the TEMP switch to SHORT and adjust the A-HI-Z pot for -5355 mV at the A-HI test point on the sensor card. Adjust the A-LO-Z pot for -830 mV at the A-LO test point on the sensor card.
5. Set the TEMP switch at 50 and adjust the A-HI-G pot for 500 mV at the DVM jack.
6. Set the TEMP switch at 300 and re-adjust the A-HI-Z pot for 3000 mV. Repeat 4 and 5 until 500 and 3000 readings are obtained.
7. Set the TEMP switch at 13 and adjust the A-LO-G pot for 130 mV on the DVM.
8. Set the TEMP switch at 18 and re-adjust the A-LO-Z pot for 180 mV on the tester DVM. Repeat 6 and 7 until 130 and 180 readings are obtained.
9. Repeat 2 thru 8 for B circuit.

* NOTE: The following new resistor values must be used on the VLBA sensor card for use with the DT-471:

R41, R62 = 619 K; R42, R63 = 61.8 K;
R45, R66 = 19.1 K; R46, R67 = 162 K.

CALIBRATION OF VACUUM SENSOR CIRCUITS
VLBA SENSOR CARD D53200A003

Roger D. Norrod

March 1, 1989

The VLBA sensor card incorporates two vacuum sensor circuits designed to work with the Hastings DV-6R thermocouple tube. The two circuits are designated PUMP and DEWAR. Calibration of the circuits is done in the following manner:

1. Connect the DEWAR sensor cable to a DV-6R tube at atmospheric pressure. Connect a 4 1/2 digit DVM to the Dout test jack. (Alternately, the dewar cardcage internal meter can be used. Select the V_D position.) Adjust the DATM pot for a meter reading of 10.000 ± 0.005 volt.
2. Connect the DEWAR sensor cable to a DV-6R tube mounted on a cold dewar. (Here we assume that the cold dewar pressure is $\ll 1$ micron.) Adjust the D ZERO pot for a reading of 0.000 ± 0.020 volt.
3. Repeat steps 1 and 2 until the desired readings are obtained without further adjustments. The thermocouple tube requires several seconds to respond to adjustments, and the zero point, especially, is sensitive to ambient temperature. Allow the tube to stabilize for a couple of minutes when making the final adjustments.
4. Repeat 1-3 for the PUMP circuit.

NOTE:

Instead of a tube on a cold dewar to adjust the zero point, a Hastings DB-20 reference tube can be used. Adjust the ZERO pot for a reading of $0.161 \text{ V/micron} \cdot \text{PREF}$ microns where PREF is the pressure of the reference tube. A "standard" sensor card should be maintained to periodically check the output reading of the reference tube. This adjustment method should be regarded only as a rough setting. The zero point of the vacuum monitor circuits is sensitive to the length of the sensor cable, temperature, and other factors. Final adjustment should be made with the dewar and cardcage under conditions as close as possible to those that will be encountered in operation.

Calibration Values for DT-471 sensor

$T(K)$	$V_{SENS}(mV)$
300	-518,9
50	-1070,5
18	-1249,3
13	-1345,3

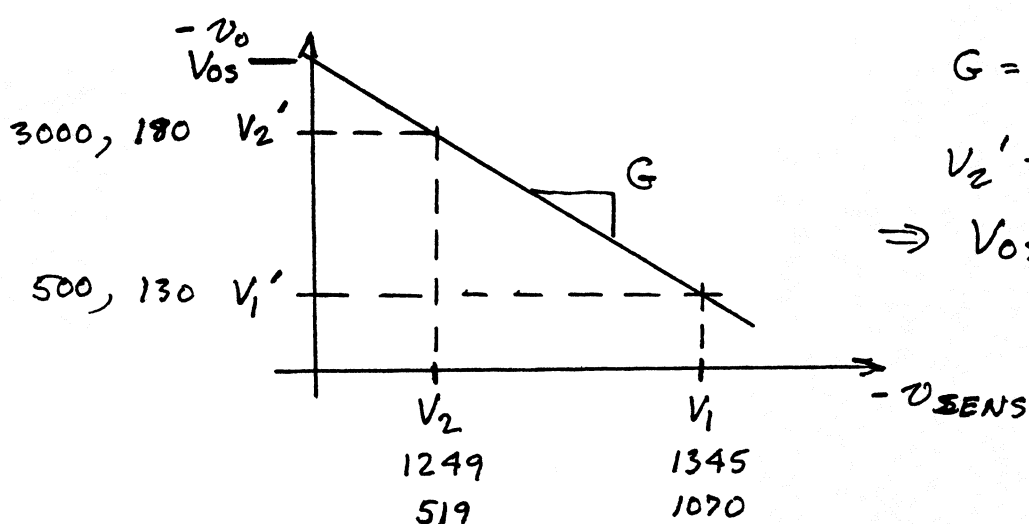

$$G = \frac{V_2' - V_1'}{V_1 - V_2}$$

$$V_2' = V_{OS} - G \cdot V_2$$

$$\Rightarrow V_{OS} = V_2' + G \cdot V_2$$

Low Range:

$$V_2' = 180, \quad V_2 = +1249$$

$$V_1' = 130, \quad V_1 = +1345$$

$$\Rightarrow G = +0.5208 \Rightarrow V_{OS} = +830 \text{ mV}$$

High Range:

$$V_2' = 3000, \quad V_2 = 519$$

$$V_1' = 500, \quad V_1 = 1070$$

$$\Rightarrow G = +4.5372 \Rightarrow V_{OS} = +5355 \text{ mV}$$

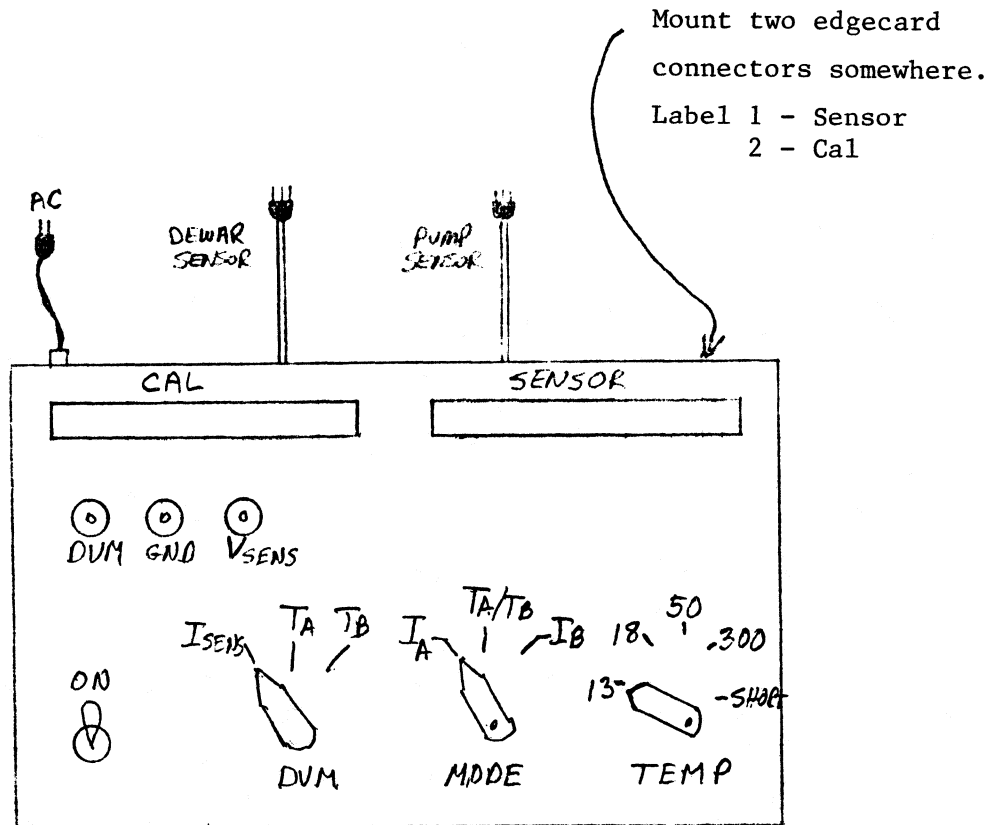

SENSOR CARD CALIBRATION BOX

R. Norrod
7/29/88

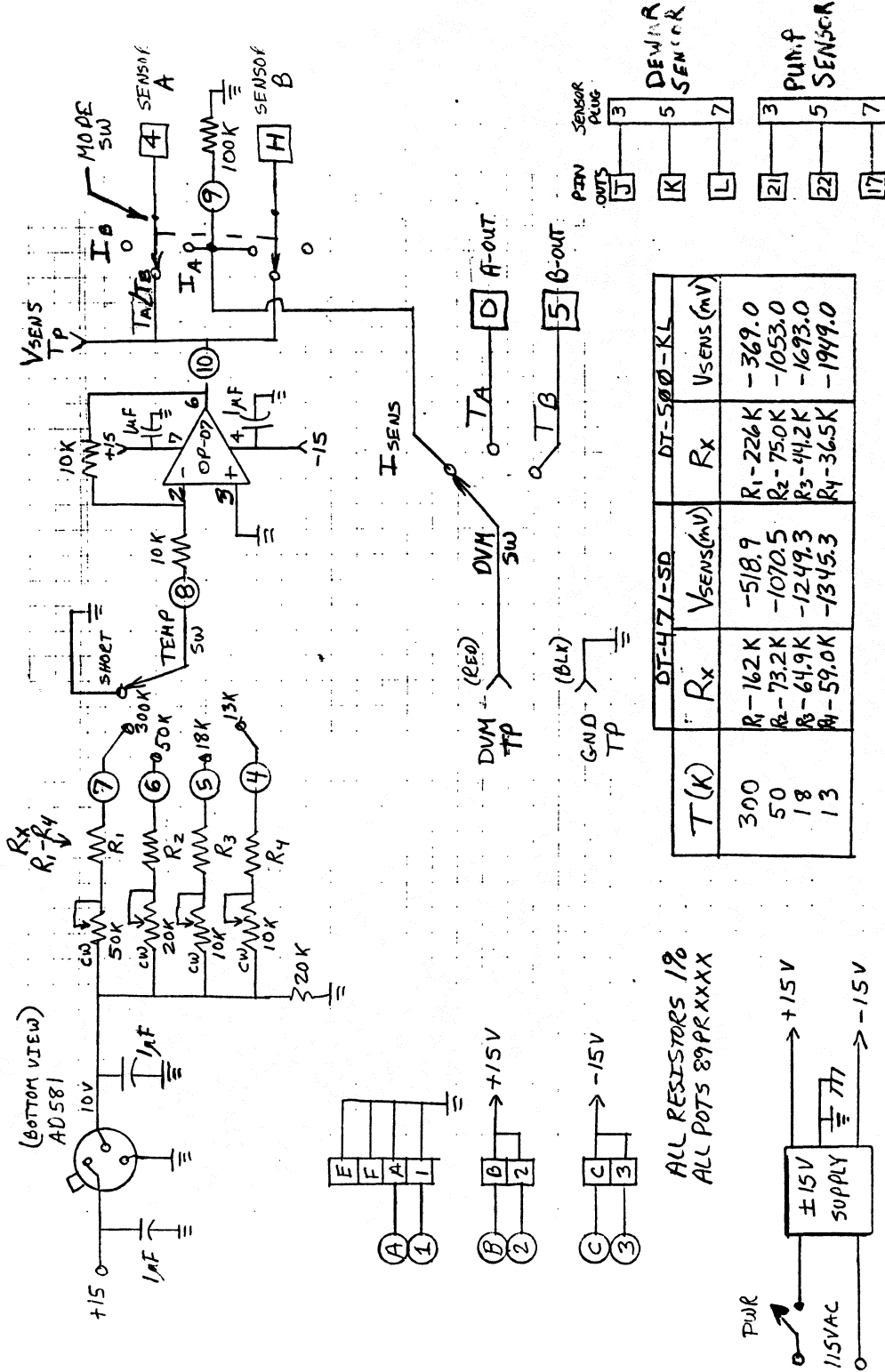

□ ⇒ EDGE CARD, SENSOR CARD
○ ⇒ " " , CAL CARD

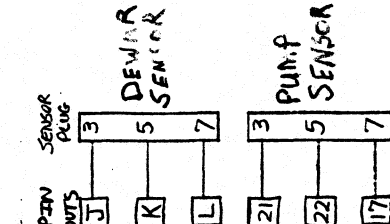
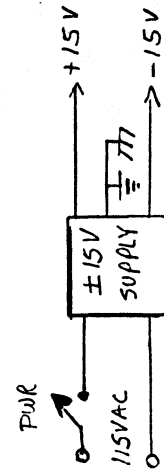

SENSOR CARD CALIBRATION BOX
FOR DT-471-SD / DT-500-KL
RDN 7/28/88

FIGURES

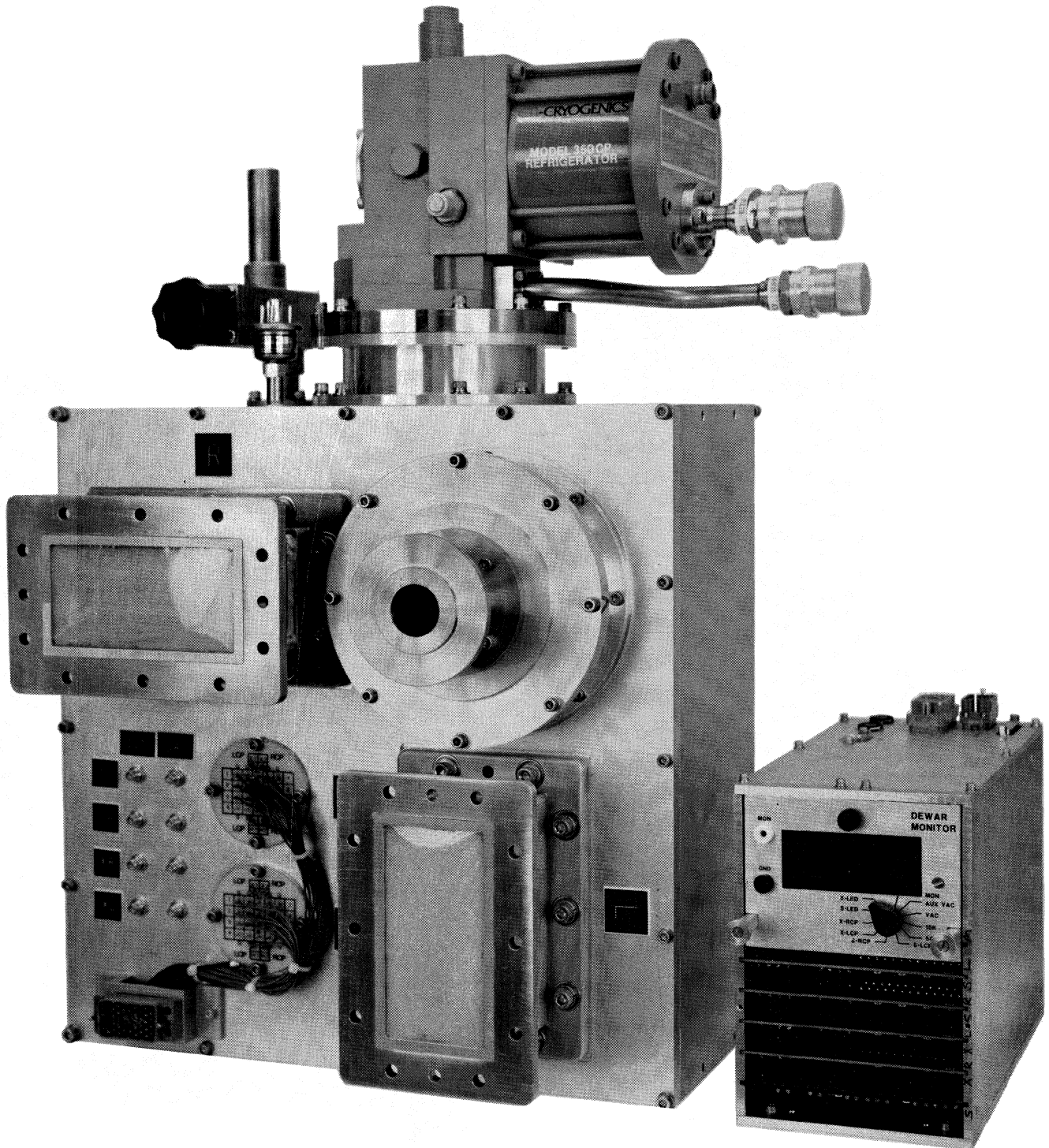

FIGURE 1
S/X Dewar Assembly

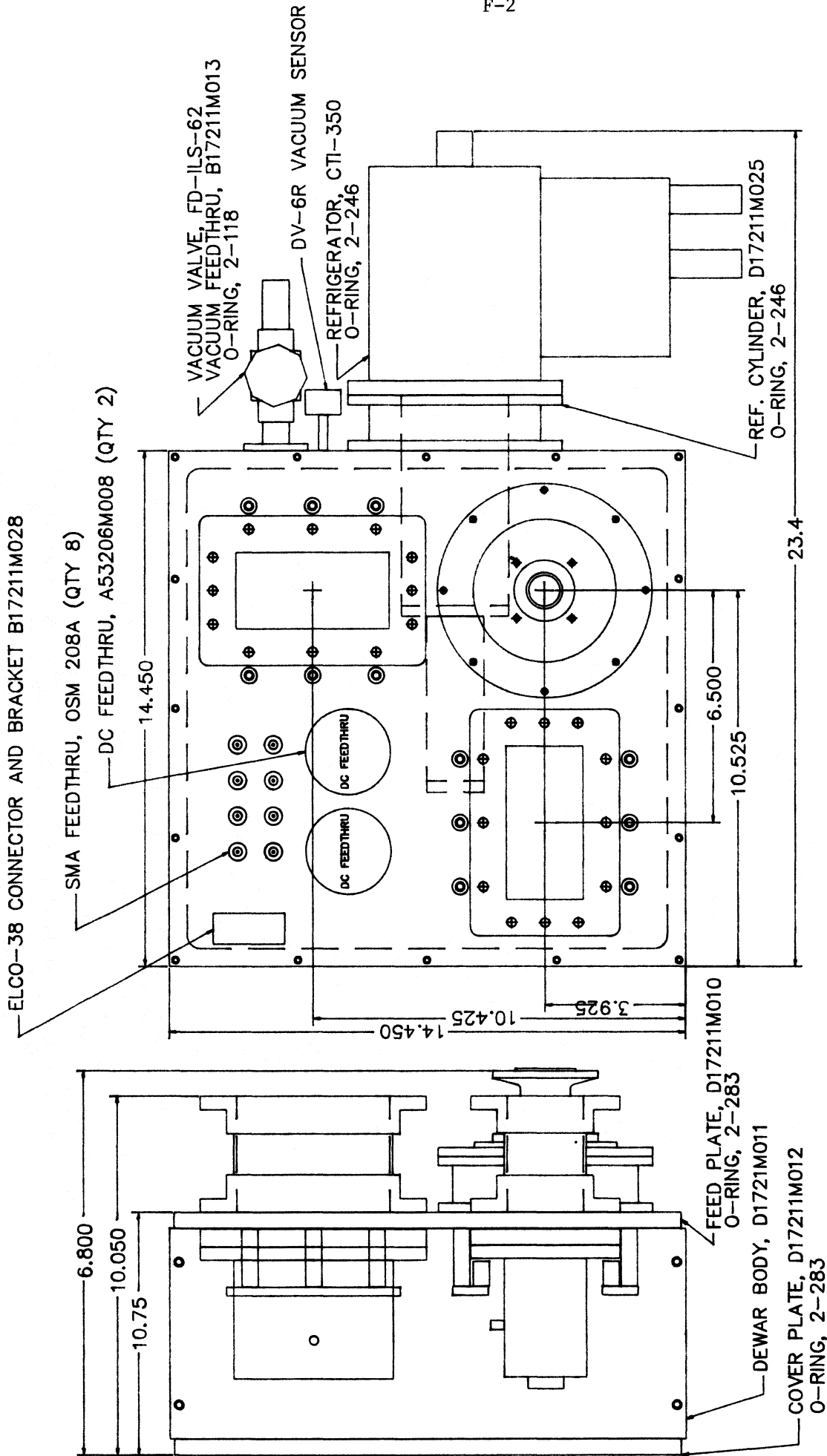

Figure 2
Dewar Interface

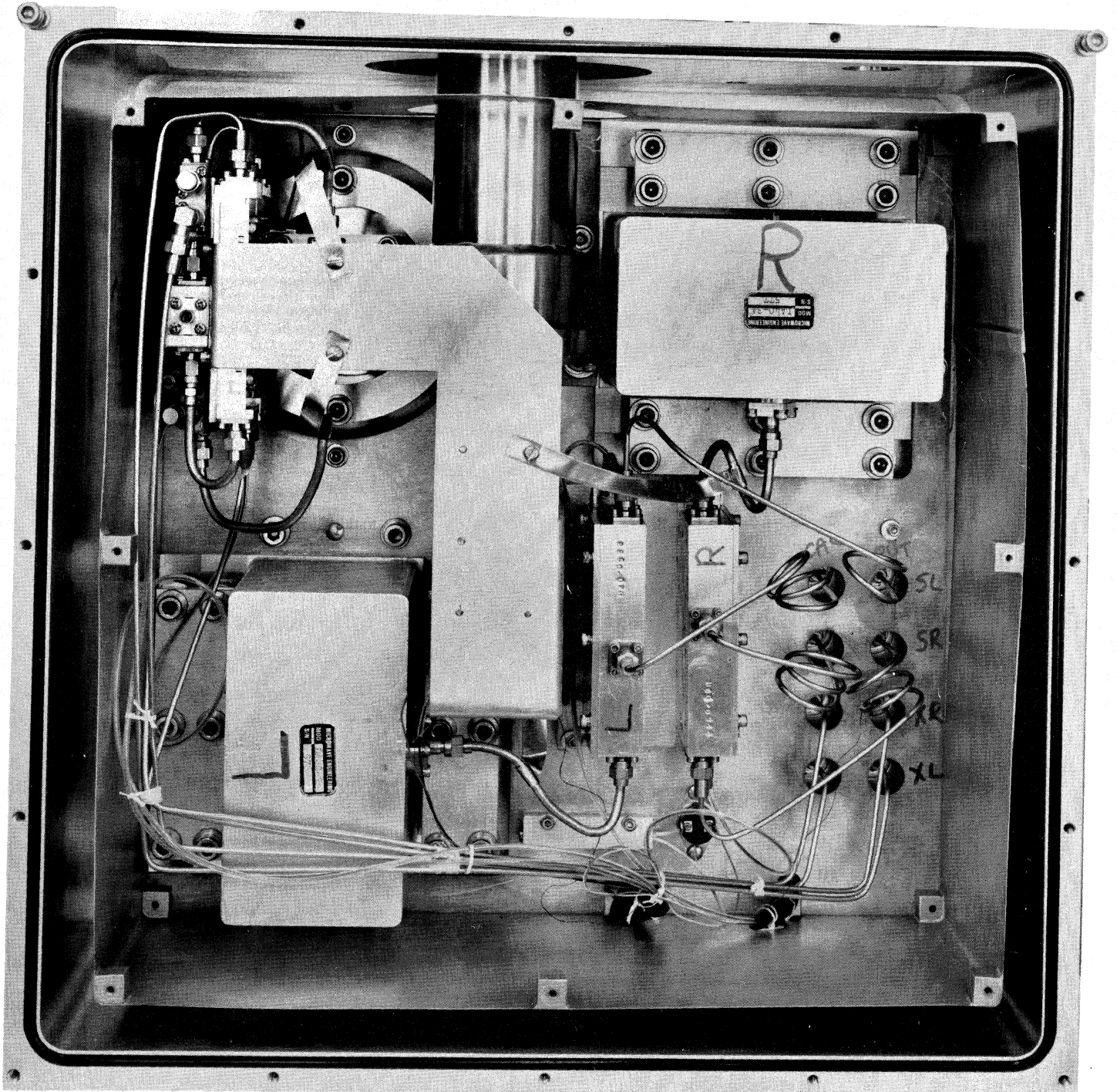
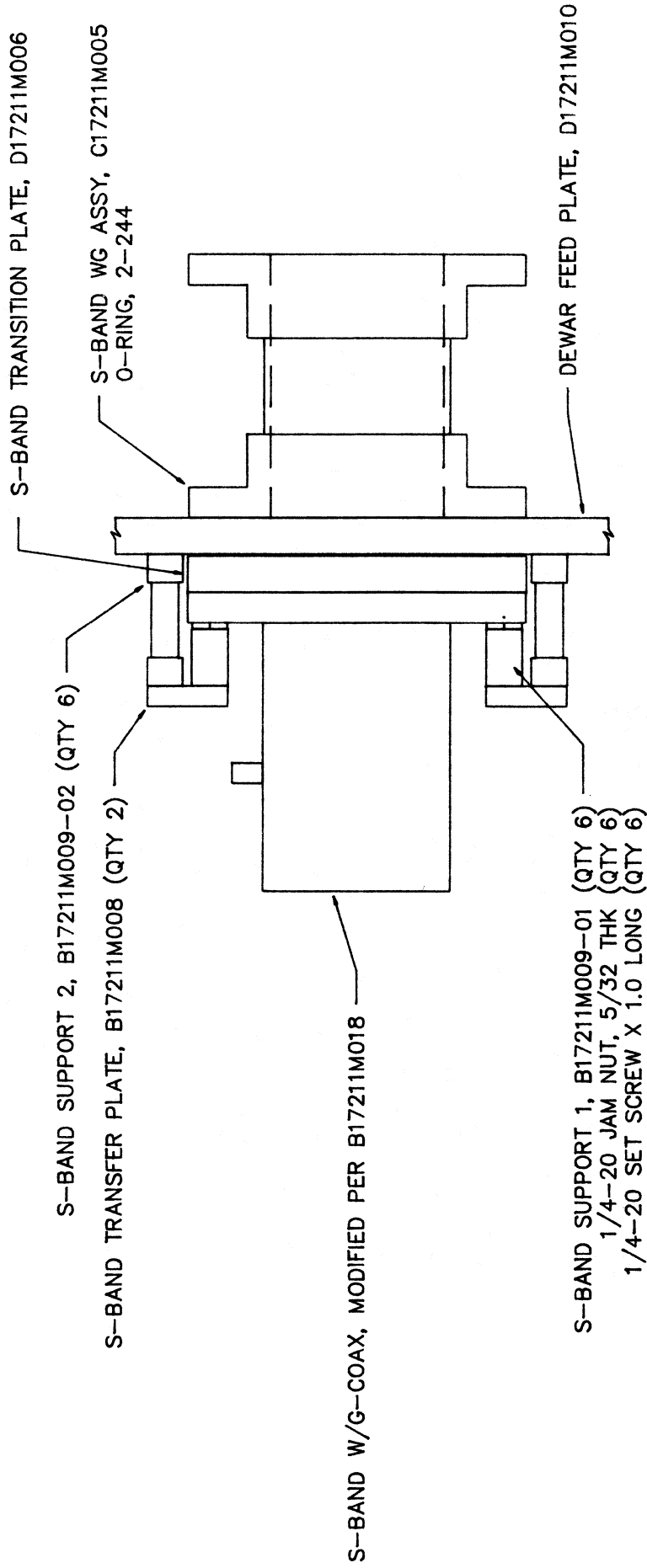
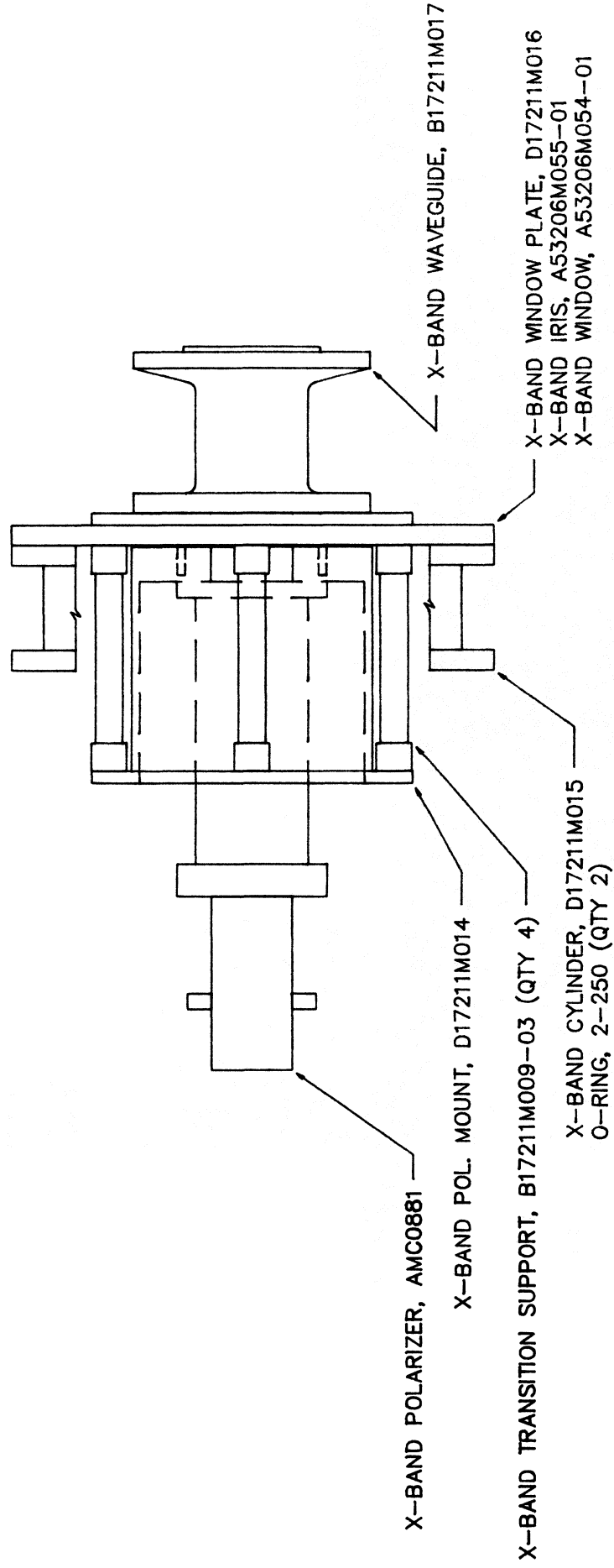

FIGURE 3
Dewar Interior



NOTE: ADJUST LENGTH OF SUPPORTS FOR 0.012±0.002 GAP

Figure 4
S-Band Transition Details



NOTE: ADJUST LENGTH OF SUPPORTS FOR 0.012 ± 0.002 GAP

Figure 5
X-Band Transition Details

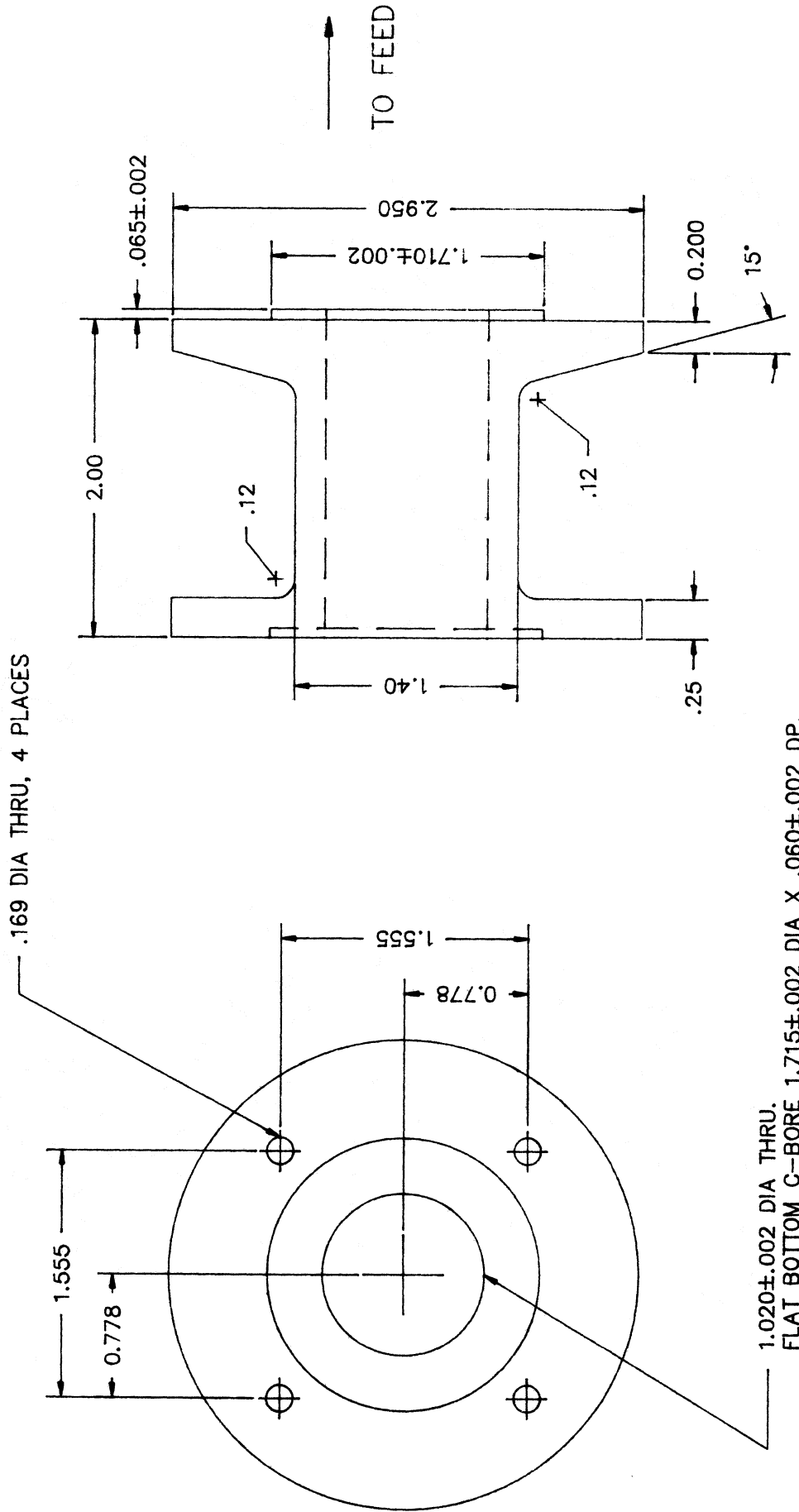

Figure 6
X-Band Waveguide Interface

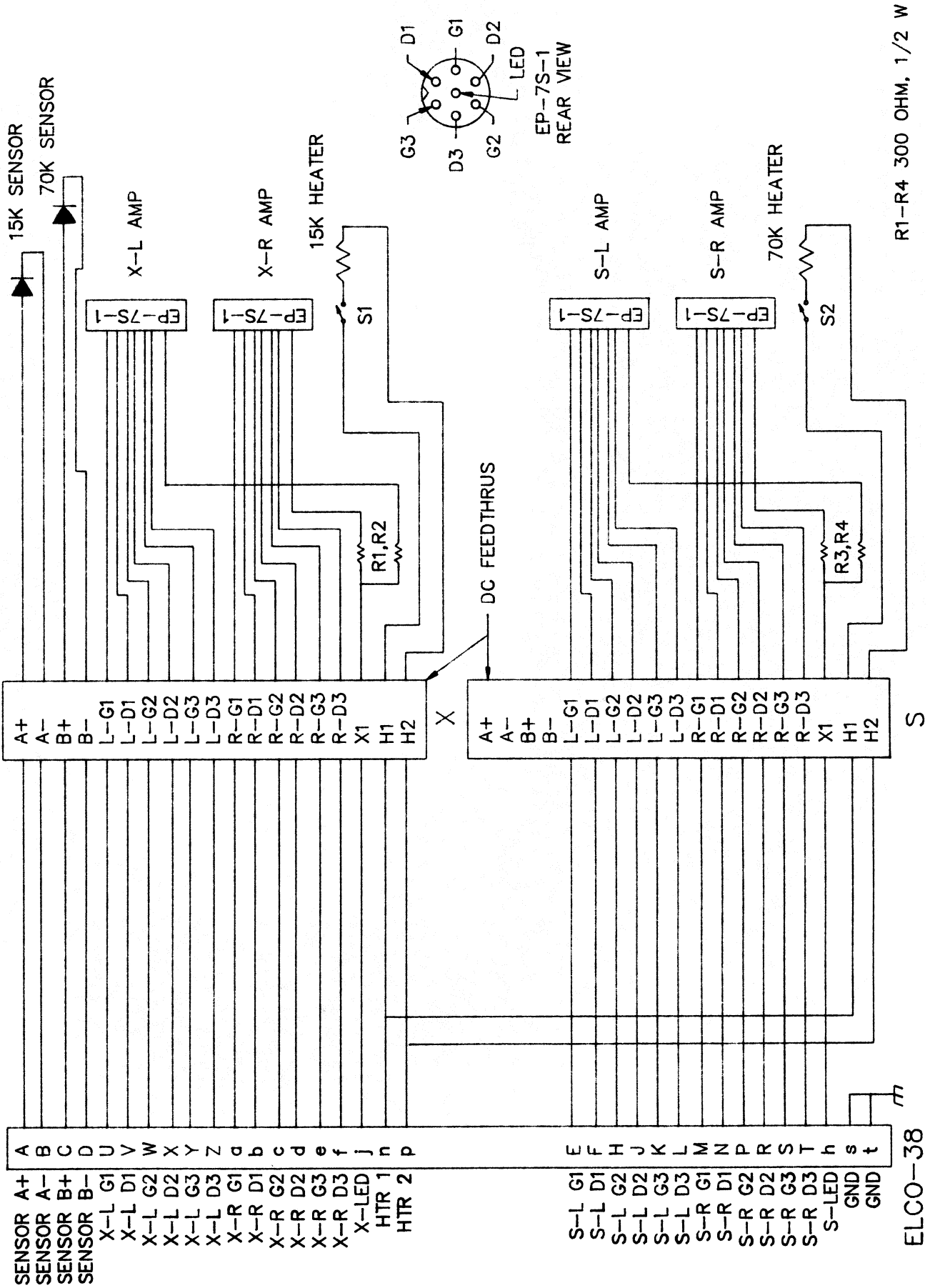

Figure 7
Dewar Wirina

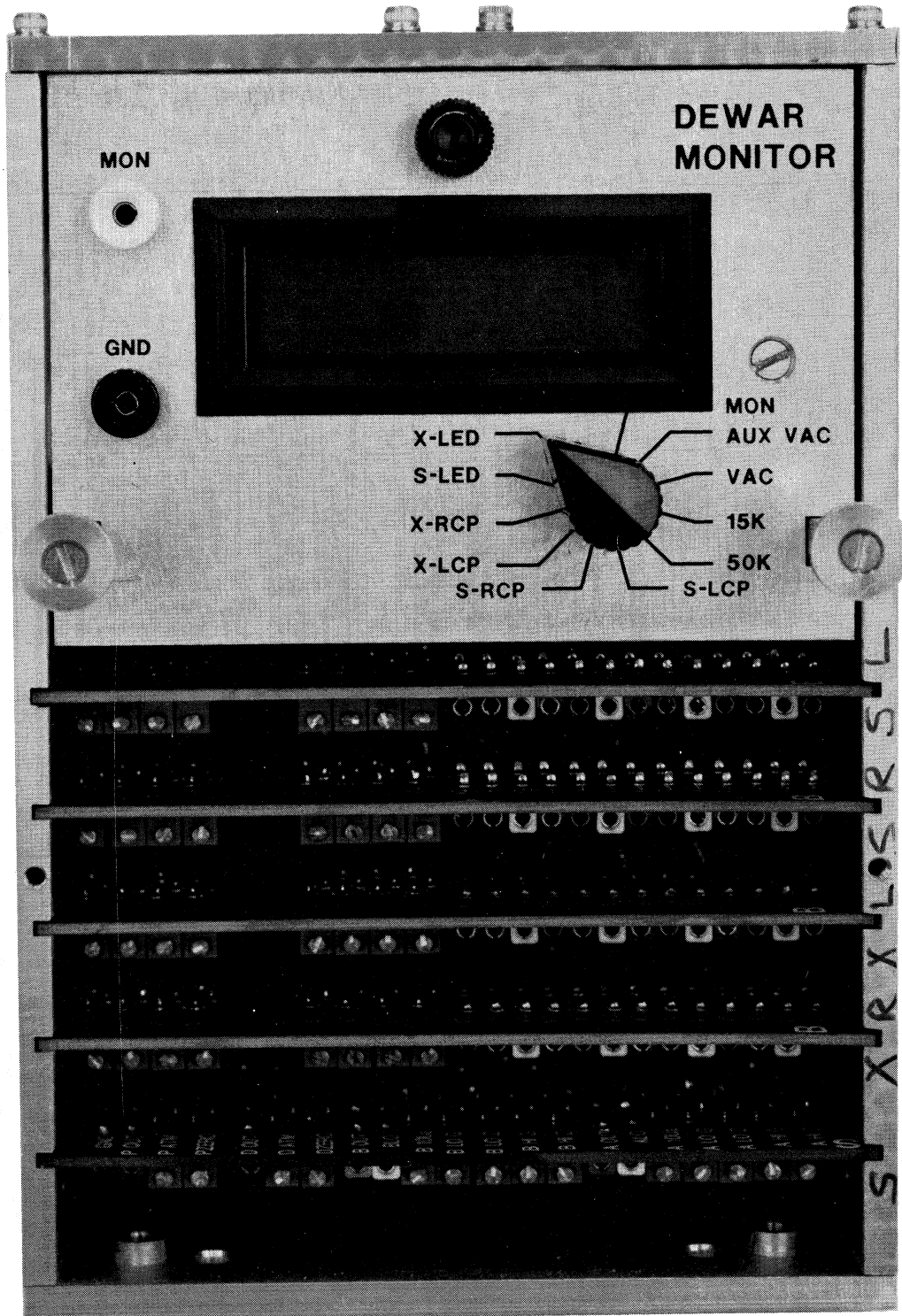

FIGURE 8(a)
Dewar Cardcage

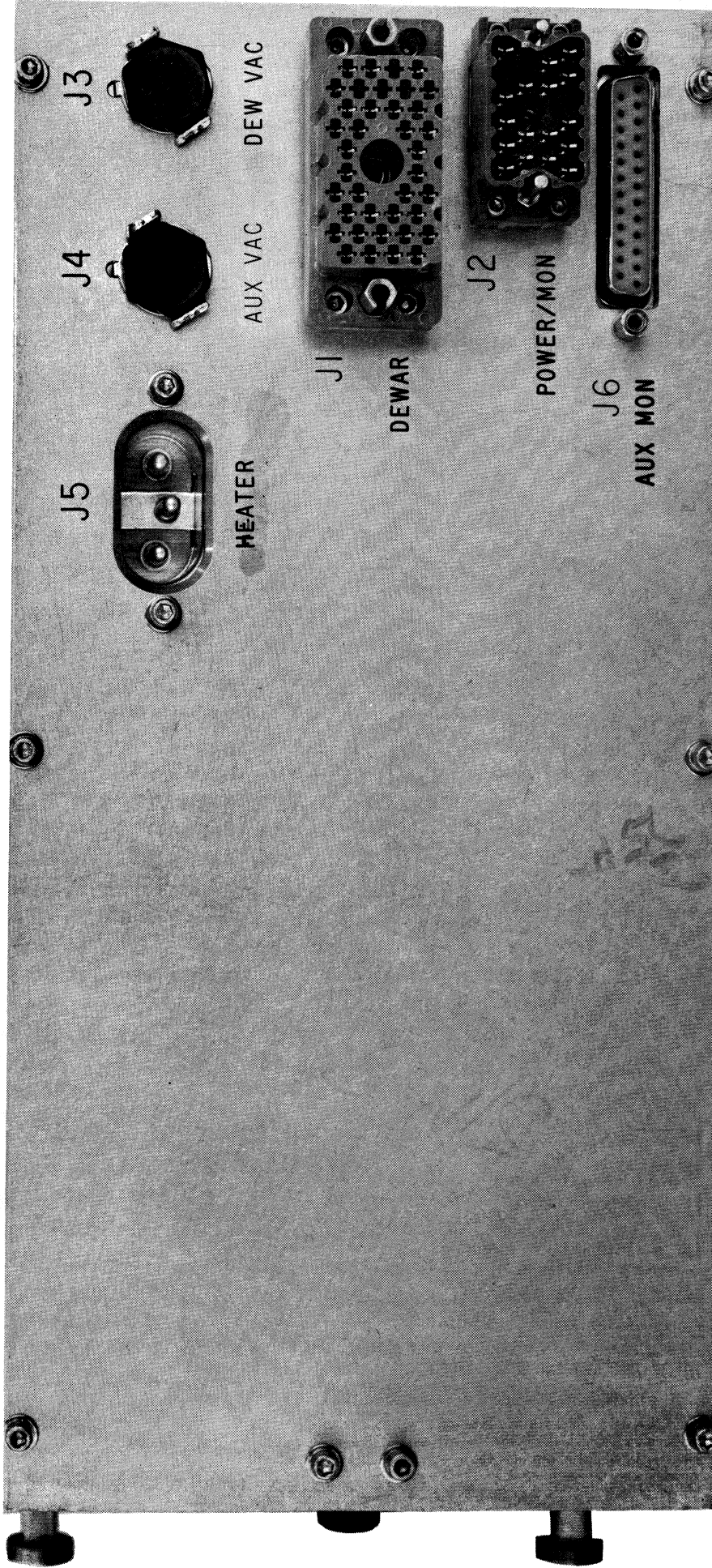

FIGURE 8 (b)
Dewar Cardcage Top Plate

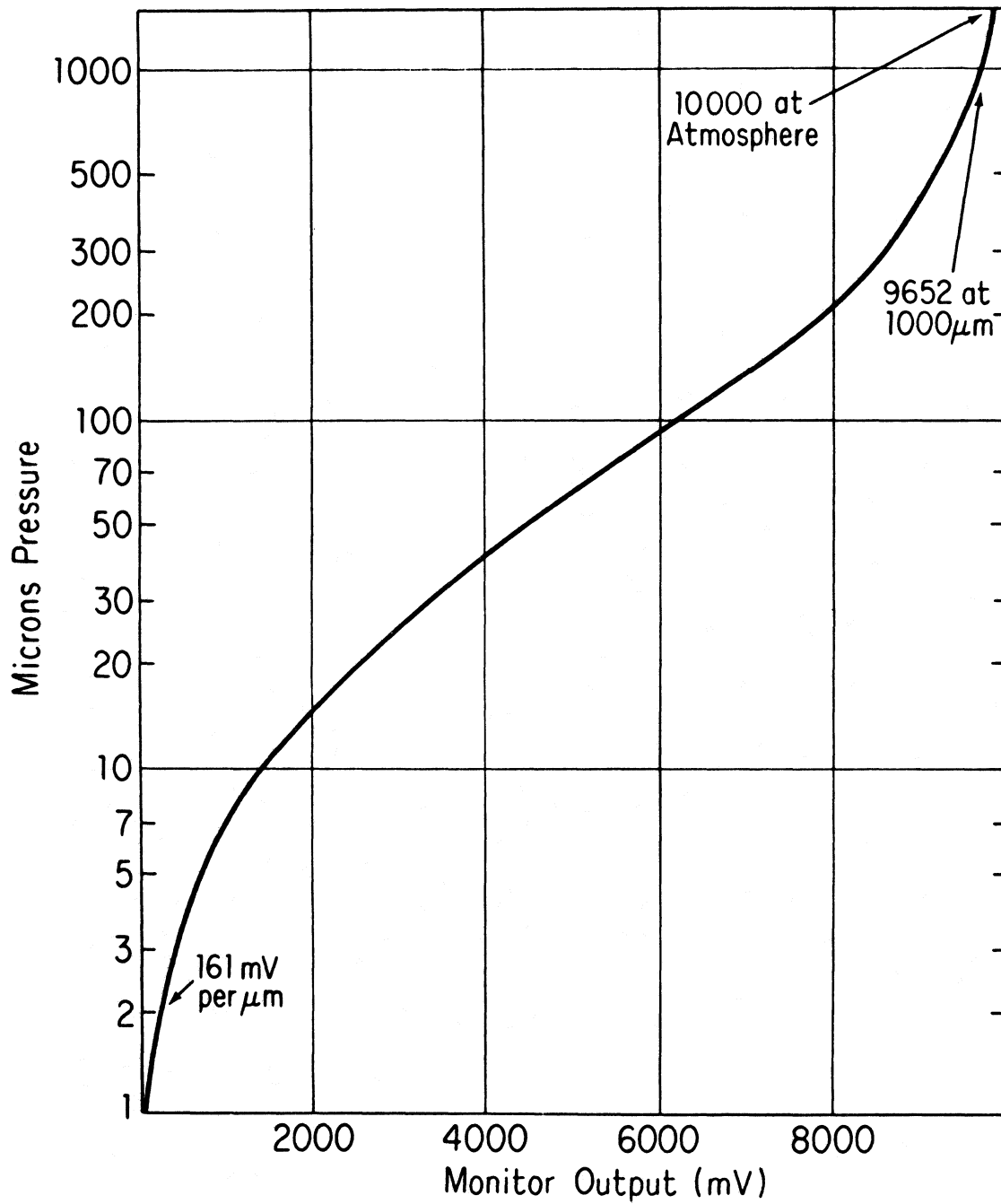

FIGURE 9

Vacuum Sensor Circuit Output Voltage vs. Pressure

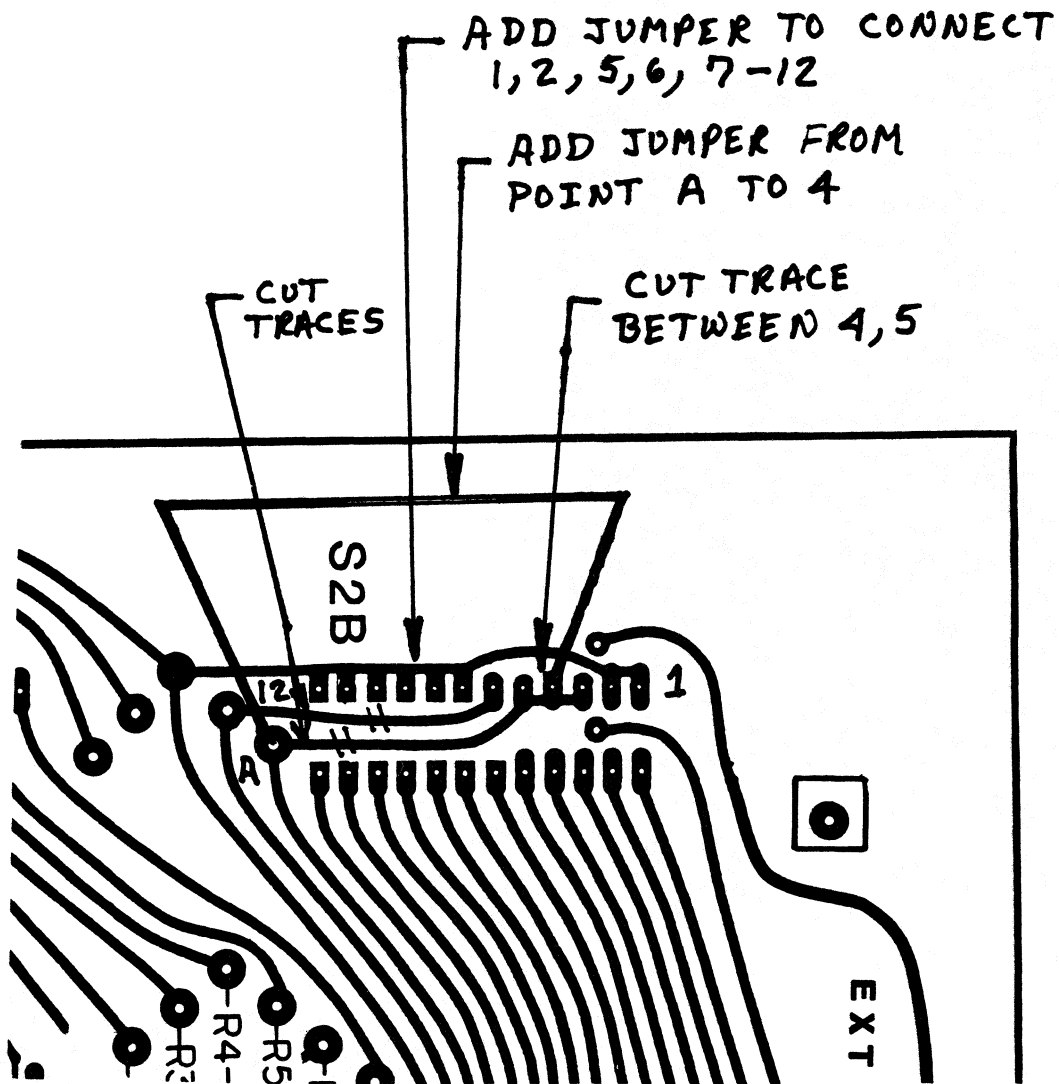

FIGURE 10

Modification to Monitor Card for S/X Cardcage