

NATIONAL RADIO ASTRONOMY OBSERVATORY
CHARLOTTESVILLE, VIRGINIA

ELECTRONICS DIVISION INTERNAL REPORT No. 214

SQUARE-LAW DETECTOR TESTS

S. WEINREB

MAY 1981

NUMBER OF COPIES: 150

SQUARE-LAW DETECTOR TESTS

Table of Contents

I.	Introduction	3
II.	Test System Description	4
III.	Detector Description	8
IV.	Results	9

Appendices

Appendix I	Square-Law Error Definition	15
Appendix II	Digital Attenuator and Driver	16
Appendix III	DETECTOR1 Program	17
Appendix IV	Noise Analysis	26

Figures

Figure 1	Block Diagram of Test Measurement System	5
Figure 2	Definition of Detector Error	6
Figure 3	Examples of Power Meter Comparisons	7
Figure 4	Detector Photograph and Schematic	10
Figure 5	Current-Voltage Characteristic of Two BD-4 Diodes	11
Figure 6	Example of Use of Square-Law Error Program	12
Figure 7	Example of Noise Tests of a Detector and Amplifier	13
Figure 8	Examples of Noise Tests of Operational Amplifiers	14

SQUARE-LAW DETECTOR TESTS

I. INTRODUCTION

The purpose of this report is to describe an automated test system for measuring the square-law error (i.e., deviation from a linear output voltage vs input power relation) and noise level of an accurate back-diode detector. A few days of operation of the system gave informative results regarding linearity of power meters, error of a back-diode detector circuit vs load resistor and input signal level, and very low-frequency noise of operational amplifiers; these results will be described.

It should be noted that all detectors become perfectly square-law at sufficiently low signal level and it is the noise level which then limits performance. The dynamic range of the detector; i.e., the input power range between noise level and an acceptable square-law error is thus an important parameter.

The noise in a detector circuit is predominately in the low-frequency amplifier following the detector rather than in the detector non-linear element and usually has a $1/f$ type spectrum. For detection of a noise-like signal, as occurs in radio astronomy, the inherent fluctuation in detector output due to this noise-like signal has a flat video spectrum with power level inversely proportional to IF bandwidth. In order for the radiometer sensitivity to be limited by this inherent noise, it must be greater than the detector noise. This criteria is more difficult to meet at wide IF bandwidth and low video bandwidth (long averaging time). As a numerical example, the detector described in this report has detector noise equal to inherent noise at an IF bandwidth of 1 GHz, averaging time of 1 second, and 0.2% square-law error.

II. TEST SYSTEM DESCRIPTION

A block diagram of the detector test system is shown in Figure 1. A digitally-controlled attenuator, 0 to 31 dB in 1 dB steps, is used to provide a variable-level noise or CW signal which is simultaneously applied to both a power meter and the detector under test. Detector error is determined by comparing power meter and detector output voltages; the attenuator accuracy and repeatability has a negligible effect upon measurement accuracy. The zero offset of both the power meter and detector is determined for each measurement and is used to correct data. A definition of square-law error and its computation is described in Appendix I. In general terms, the error is defined as the percent deviation of the detector output voltage vs input power curve from a straight line passing through a reference power level and .01 times this reference level, see Figure 2. The analog/digital input-output system, ADIOS, for the Apple II Plus Computer is described in NRAO Electronics Division Internal Report No. 212. The digital attenuator and driver are described in Appendix II of this report.

Since a power meter is the measurement standard for determining square-law error, four power meters were first compared using the square-law error measurement program. These were the General Microwave 467A, H-P 436A/8485A, H-P 432A/478A, and H-P 436A/8484A. The first two are thermoelectric sensors, the third is a thermistor sensor, and the fourth is a diode detector. Some results are illustrated in Figure 3. In general, the error between the first 3 power meters and the last meter at 1 μ W or lower scale is $< 0.3\%$. The H-P 436A/8484A on the 10 μ W scale has $\sim 1\%$ error in the 3 to 10 μ W range and should not be used as a standard at this high level.

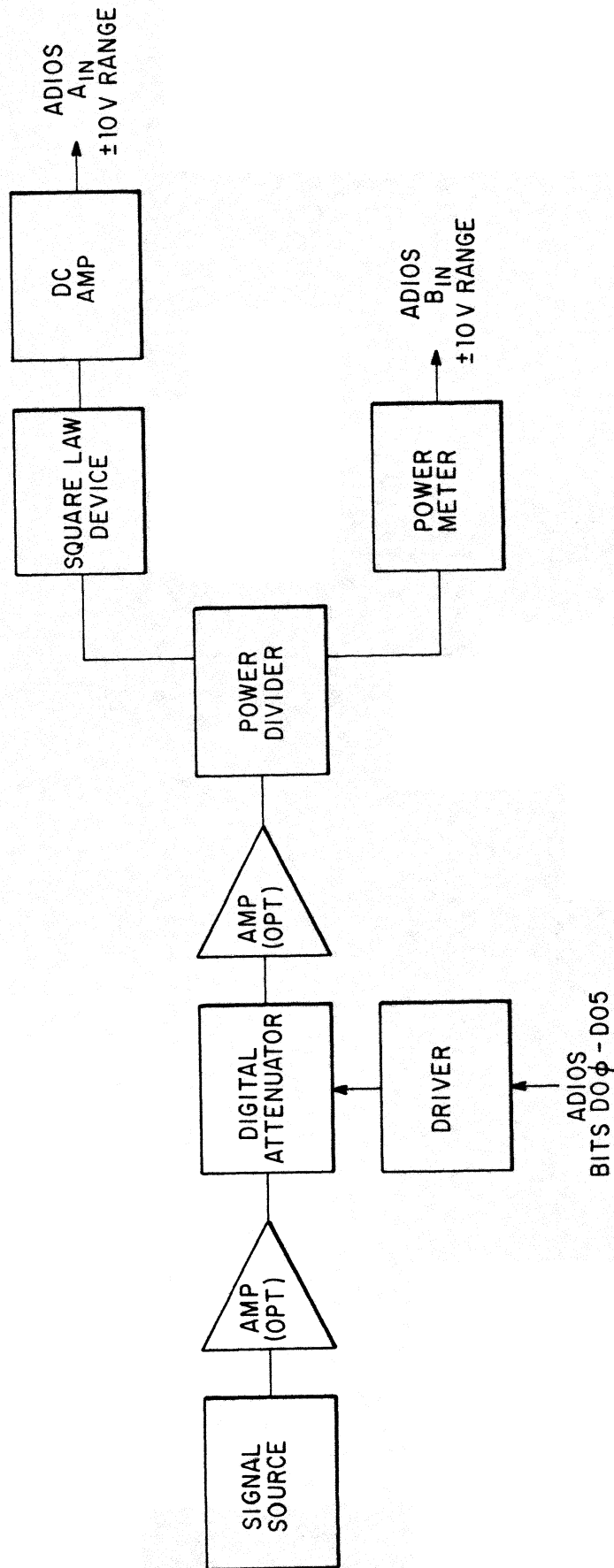

Fig. 1. Block diagram of test measurement system. ADIOS is an analog-digital input-output system for the Apple Computer and is described in NRAO EDIR No. 212.

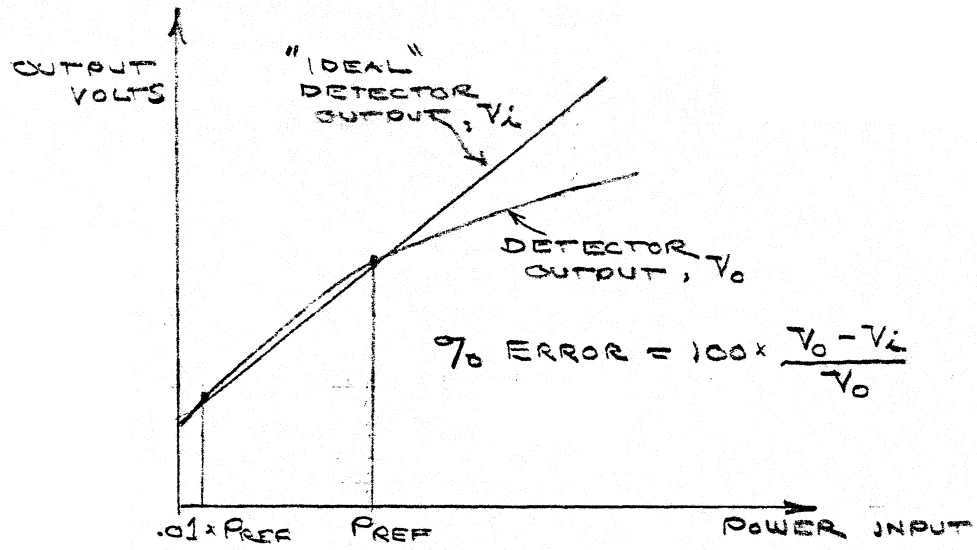
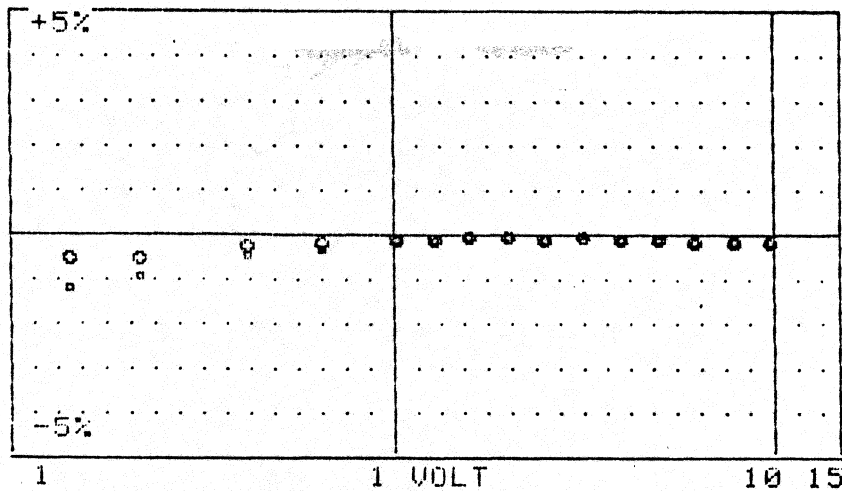
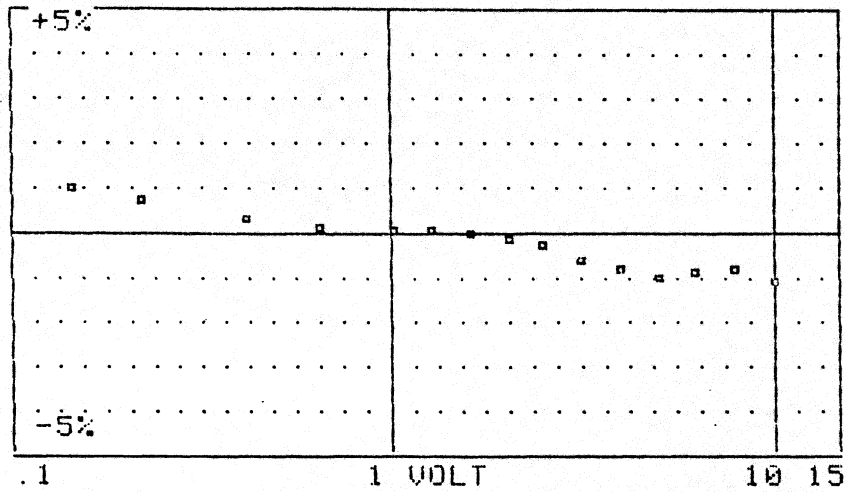

Fig. 2. Definition of detector error; also see Appendix I.

HP 432A, 1MW SCALE, INTO AIN; GM 467A, 1MW SCALE, INTO BIN. 2-300MHZ NOISE SIGNAL



HP 436A/8484A INTO AIN, 100W SCALE; HP 432A INTO BIN, 1MW SCALE. NOISE SIGNAL



HP 436/8484A, 100NW SCALE, INTO AIN; HP432, 1MW SCALE, INTO BIN. NOISE SIGNAL.

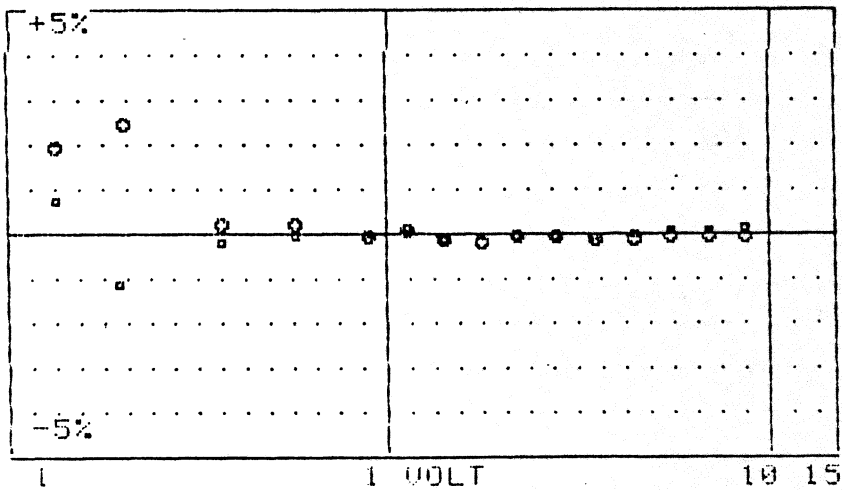

Fig. 3. Examples of power meter comparisons. The horizontal axis is 10 times the meter DC output voltage; for values < 1 volt the error is determined by noise and should be ignored. The middle curve shows an $\sim 1\%$ error of the HP436A/8484A meter at its maximum input level of 10 μW . A broadband, 2-300 MHz, noise signal was used for these tests.

III. DETECTOR DESCRIPTION

The detector used for these tests was one similar to a design used at NRAO for many years.¹ A General Electric BD-4 back-diode is utilized into an adjustable, 0-5k ohm, load resistance connected to the summing input of an operational amplifier; a schematic of the detector and a photograph are shown in Figure 4. The load resistance is adjusted for minimum square-law error.

The input op amp is a low-drift, low-noise variety; three types were tried and noise test results are reported in the next section. The input op amp is operated at typical voltage gain of 100 and output voltage of < 1 volt to eliminate thermal transients which may occur if an op amp is operated at high-level output. The entire circuit is enclosed in a 3/4" x 3 1/4" x 1 1/2" box which includes a mu-metal shield to reduce 60 Hz AC pickup from nearby power supply transformers. The RF input match is a function of input layout and perhaps diode capacity. For the constructed unit the input return loss is > 20 dB from 5 to 500 MHz and > 10 db from 2 to 800 MHz.

It should be noted that the performance of a detector can be calculated in terms of the derivatives of the current-voltage characteristic; i.e., a non-linear device with all derivatives zero except first and second will give perfect square-law response. An excellent reference on this subject is given by Cowley and Sorensen.² These calculations have not been performed for the back-diode detector. However, a calculation of the square-law range of a biased-Schottky diode has shown that it will have a much smaller dynamic range than measured for the back-diode detector.

The BD-4 diodes which were tested for this report gave quite variable results from one diode to another. Four out of eight diodes gave acceptable

¹ Peter Camana, "The GE BD-7 Back Diode as a Square-Law Detector," NRAO Electronics Division Internal Report No. 106, September 1971.

² A. M. Cowley and H. O. Sorensen, "Quantitative Comparison of Solid-State Microwave Detectors," IEEE Trans. Microwave Theory Tech., vol. MTT-14, no. 12, pp. 588-602, December 1966.

square-law performance of less than 0.5% error at < -16 dBm RF input level. The remaining diodes could not achieve this; increasing the load resistance decreased error but not to an acceptable value at 5,000 ohms. Larger load resistances were not tried as the error was not decreasing appreciably as 5k was approached. The I-V characteristics of two BD-4 diodes are shown in Figure 5 and are quite different. However, no correlation has been made between the I-V characteristic and square-law performance.

IV. RESULTS

The results of tests upon a particular detector, #3, are shown in Figures 6, 7, and 8 with discussion in the captions of each figure.

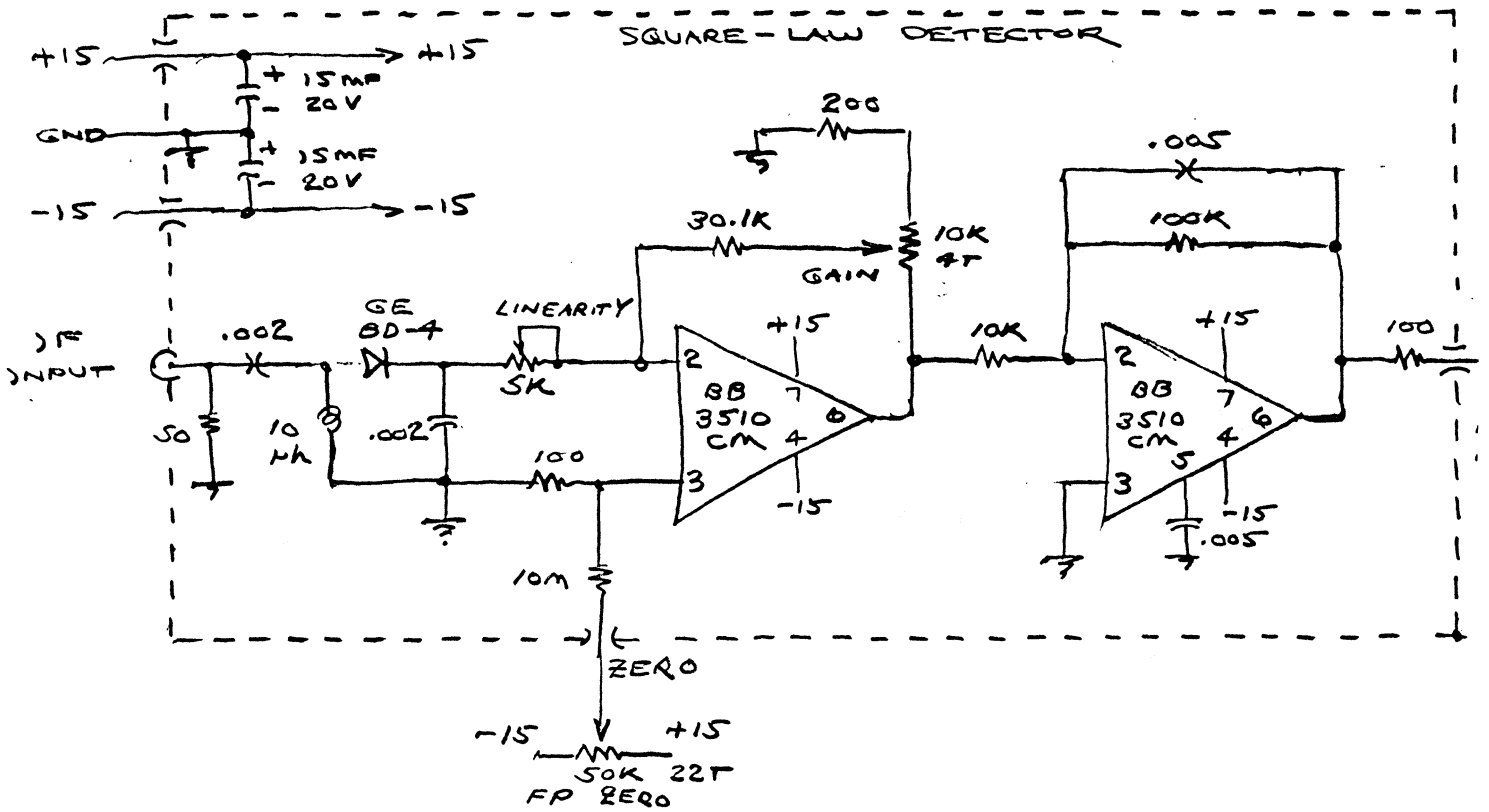
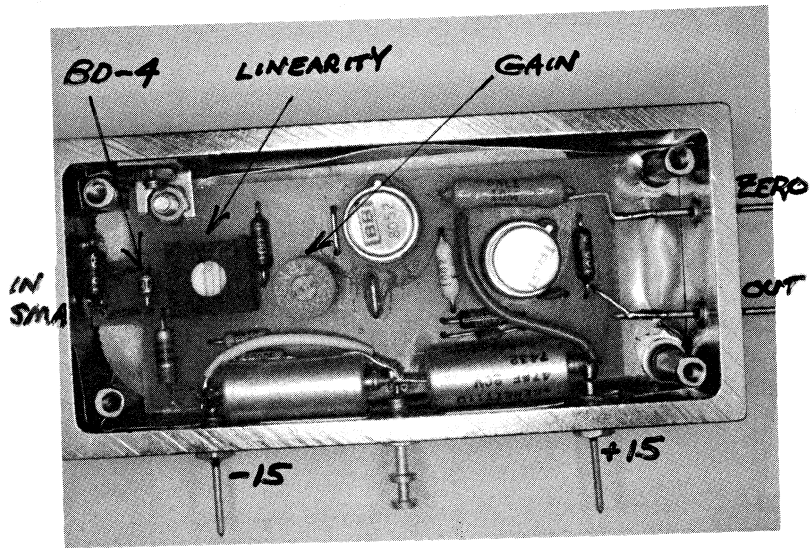

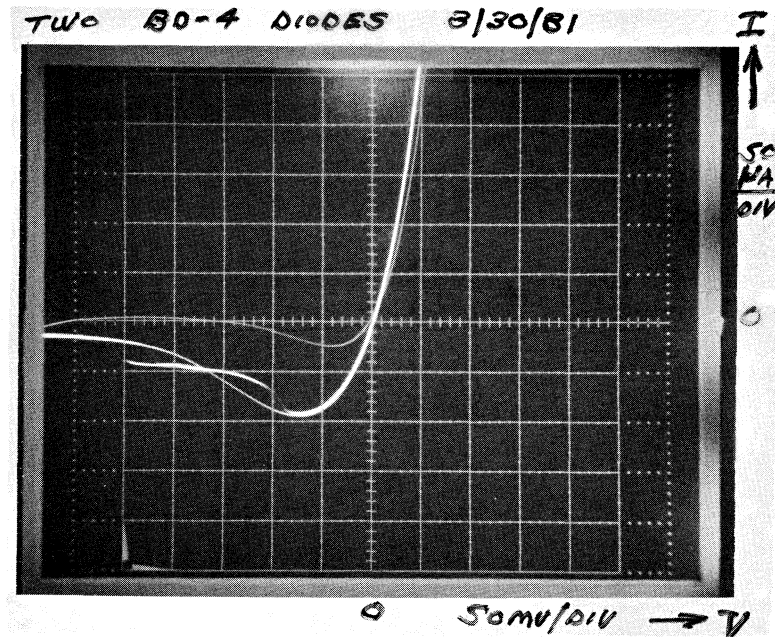
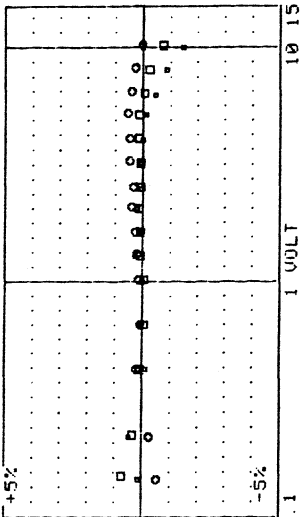
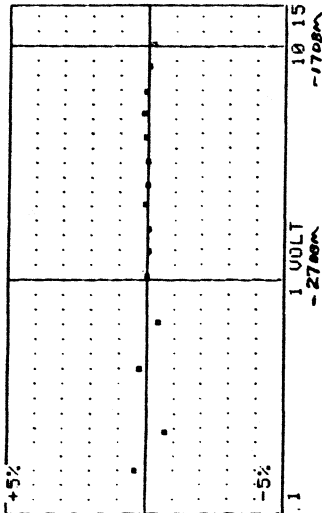

Fig. 5. Current-voltage characteristic of two BD-4 diodes (dim curve and bright curve). An instability, due to negative resistance oscillations occurred on the bright curve but could be suppressed by small capacitance (fingers!) across the diode. The slope of the I-V characteristic at the origin is the video output conductance of the detector; for the bright curve above, this is $1/(330 \text{ ohms})$.

DETECTOR #3, -150dB AT 10VOLTS, RL=5K, 3.7K, AND 2.5K



DETECTOR #3 FINAL MARCH 25, 1981



#3 AT -160dB

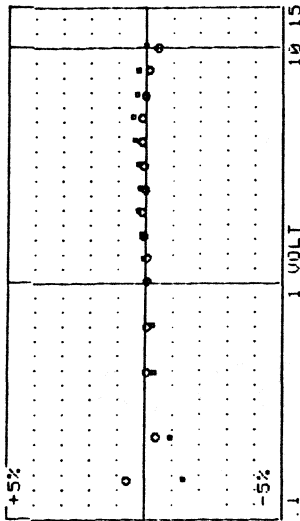

ATTEN	DET MV	S=5.14	MTR MV	ERROR	P_{IN}
31	36.3	-1.67	0%	0%	
11	1039.63	193.4	0%	0%	-1700m
1	10260.25	1990.38	-0.21%	-0.21%	
2	8180.8	1583.03	-0.07%	-0.07%	
3	6441.58	1243.65	0%	0%	
4	5188.58	999.15	0.05%	0.05%	
5	4090.5	786.2	0%	0%	
6	3256.48	624.42	-0.04%	-0.04%	
7	2588.83	490.92	0.04%	0.04%	
8	2063.48	396.2	-0.11%	-0.11%	
9	1646.13	311.67	-0.07%	-0.07%	
10	1313.63	246.85	-0.06%	-0.06%	
11	1039.63	193.53	-0.41%	-0.41%	-2700m
13	667.7	121.63	0.2%	0.2%	
15	428.05	74.33	-0.73%	-0.73%	
18	230.33	36.38	0.37%	0.37%	
20	155.42	21.38			

Fig 6. Example of use of square-law error program. The data in the top-left graph was obtained with detector maximum input power level at -15 dBm and 3 different values of detector load resistance; the detector amplifier gain was adjusted at each load resistance setting to give 10 volts amplifier output at -15 dBm input power. A desired maximum error of 0.3% could not be obtained at this power level. The maximum power level was reduced to -16 dBm (lower left graph) and finally to -17 dBm (upper right) where satisfactory performance was obtained at a load resistance of $\sim 3k$ and amplifier gain of 780. A table of attenuator dB, detector and power meter output mV corrected for zero, and % error was then printed.

SAMP=50 TIME=1000MS RMS=.107MU DRIFT=5E-03MU/S AU=1016.89MU

DETECTOR #3 -27DBM INPUT

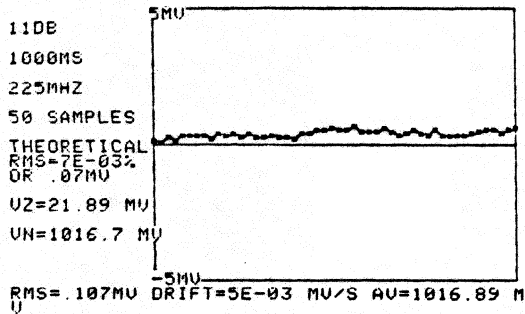

SAMP=50 TIME=1000MS RMS=.061MU DRIFT=5E-03MU/S AU=3.15MU

NO SIGNAL

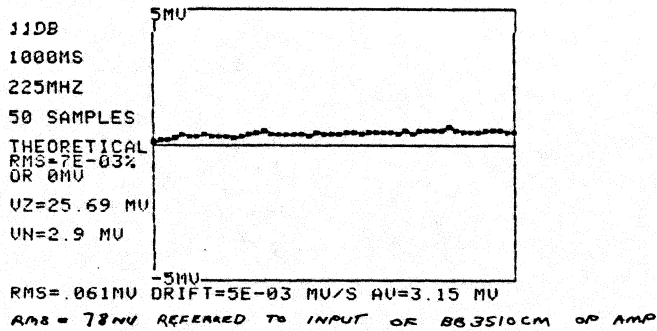

SAMP=50 TIME=1000MS RMS=.272MU DRIFT=-.016MU/S AU=4065.31MU

DETECTOR #3 , -21 DBM INPUT

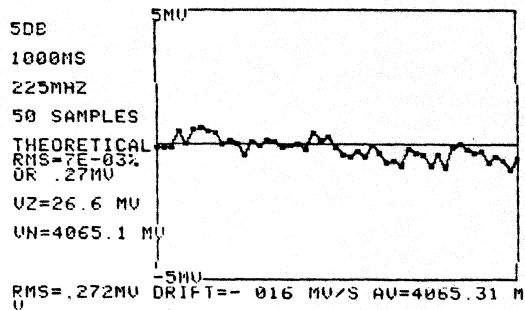
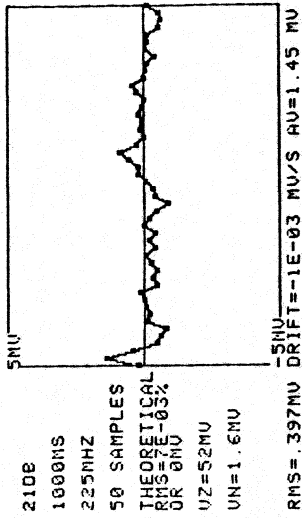

Fig. 7. Example of noise tests of a detector and amplifier. The variation in amplifier output is plotted as a function of time; more specifically, fifty one-second averages of the output minus the first average are plotted. Statistics such as the rms deviation, drift rate, and average output are then computed and printed. The theoretical rms noise due to the noisy IF input signal of stated bandwidth is also given at the left of each plot. The three plots are for different input signal levels. The middle plot, at zero input signal, shows a rms output noise of 61 μ V which is equal to the theoretical noise at ~ 0.9 volts detector output (27.5 dBm input); at this level the op amp noise is equal to the inherent fluctuation of the detected noise for 1 second.

SAHP=50 TIME=1000MS RMS=.397MU DRIFT=-1E-03MU/S AU=1.45MU
OP27CJ OP AMP. ADIOS GAIN X10 AND OP AMP GAIN=780 GIVING 51NU RMS OP
AMP NOISE.



SAHP=50 TIME=1000MS RMS=.59MU DRIFT=.057MU/S AU=1.78MU

SAHP=50 TIME=1000MS RMS=.464MU DRIFT=-.012MU/S AU=2.7MU

SAHP=50 TIME=1000MS RMS=.623MU DRIFT=.03MU/S AU=2.05MU
BURR-BROWN 3510CH. AVERAGE OF 3 IS 78NU RMS REFERRED TO INPUT

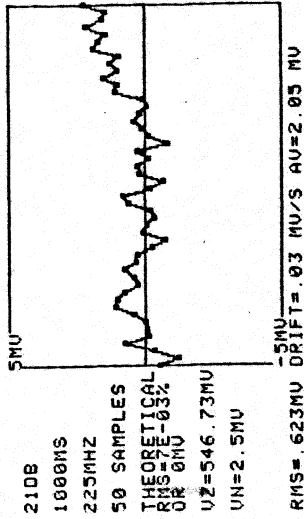

SAHP=50 TIME=1000MS RMS=.52MU DRIFT=.084MU/S AU=1.79MU

SAHP=50 TIME=1000MS RMS=.397MU DRIFT=.014MU/S AU=1.55MU

SAHP=50 TIME=1000MS RMS=.477MU DRIFT=.014MU/S AU=2.21MU
SECOND OP27. AVERAGE RMS 59NU

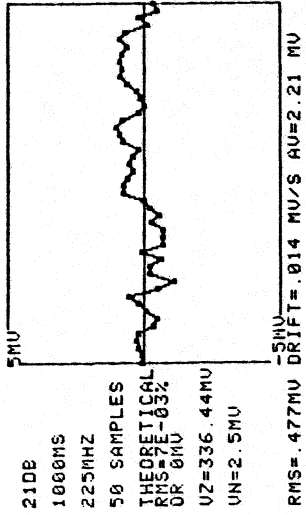

SAHP=50 TIME=1000MS RMS=1.947MU DRIFT=.105MU/S AU=-.91MU

SAHP=50 TIME=1000MS RMS=1.89MU DRIFT=-7E-03MU/S AU=5.29MU
MP-5507EJ, RMS 242NU RTI

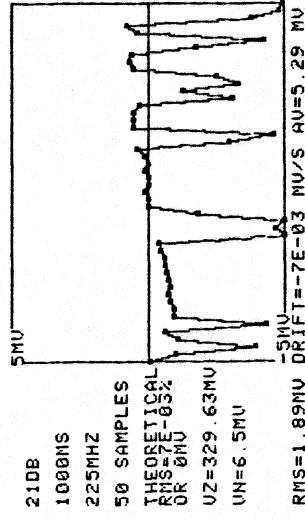

SAHP=50 TIME=1000MS RMS=.514MU DRIFT=.011MU/S AU=1.82MU

SAHP=50 TIME=1000MS RMS=.585MU DRIFT=.052MU/S AU=.82MU

Fig. 8. Examples of noise tests of operational amplifiers. Detector diode was connected, no RF signal was applied, op amp voltage gain was 780, ADIOS gain was 10, and integration time was 1 second. The rms noise is thus measured in the .01 Hz to 0.5 Hz band where it is not specified by manufacturers. The OP27CJ rms input noise is ~ 58 nV which should be compared to a specification of 250 nV peak-to-peak in the .01 to 10 Hz band.

Appendix I. Square-Law Error Definition

Let $V(K)$ and $P(K)$ be the voltages measured by ADIOS at its AIN and BIN inputs connected to the detector output and power meter outputs, respectively; zero error within ADIOS is included in $V(K)$ and $P(K)$. The digitally controlled attenuator setting, in dB, corresponding to these values is $A(K)$. The index, K , runs from 0 to N which is normally 16.

The first set of numbers, for $K = 0$, is taken at maximum attenuation, $A(0) = 31$, and is used, primarily to determine the total zero errors, VZ and PZ . The second set of numbers, $K = 1$, is taken at a reference attenuation level, $A(1) = 11$, which should be in the middle of the dynamic range of the detector. The gain factor, G , is defined as,

$$G \equiv 10^{-[A(0) - A(1)]/10} = .01,$$

and the zero offsets and scale factor, S , are computed as,

$$VZ = \frac{V(0) - G * V(1)}{1 - G} \quad (I.1)$$

$$PZ = \frac{P(0) - G * P(1)}{1 - G} \quad (I.2)$$

$$S = \frac{V(1) - VZ}{P(1) - PZ} \quad (I.3)$$

The equations for VZ and PZ reduce to $V(0)$ and $P(0)$ as $G \rightarrow 0$.

The attenuator is then stepped thru 15 values listed in the program statement 540. For each value the % error is computed as,

$$E(K) = 100 * \frac{V(K) - VZ - S * (P(K) - PZ)}{V(K)} \quad (I.4)$$

Kay Electric Co., Pine Brook, NJ

PROGRAMMABLE ATTENUATORS

- RAPID RELAY SWITCHING
- EASY FIELD SERVICE

THESE ATTENUATORS MAY BE TAILORED FOR CUSTOM REQUIREMENTS, INCLUDING FRACTIONAL STEPS - CONSULT FACTORY.

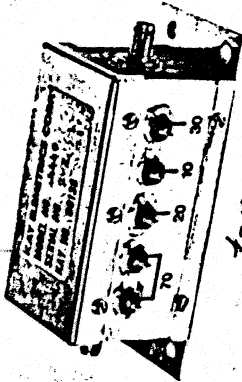

7349
50 OHMS

75 OHMS

MODEL	4448	4450	4480	4447	4457	4487
FREQUENCY RANGE (MHz)	DC-1500	DC-1500	DC-1500	DC-1000	DC-1000	DC-1000
ATTENUATION RANGE (dB)	0-130	0-127	0-130	0-127	0-127	0-31
STEPS (dB)	10, 20, 30, 70	1, 2, 4, 8, 16, 32, 64	1, 2, 4, 8, 16, 32, 64	10, 20, 30, 70	1, 2, 4, 8, 16, 32, 64	1, 2, 4, 8, 16
ACCURACY: ±dB or %dB	1.0, 1.5, 2.5	1.0, 1.5, 3.0	1.0, 1.5, 3.0	1.0, 1.5	1.0, 1.5	.5, .8
VSWR 1:	1.3:1, 1.4:1, 1.5:1	1.3:1, 1.4:1, 1.5:1	1.3:1, 1.4:1, 1.5:1	1.3:1, 1.4:1, 1.5:1	1.3:1, 1.5:1	1.2:1, 1.3:1
INSERTION LOSS (dB)	1.5, 2.0, 3.0	1.5, 2.5, 4.0	1.5, 2.5, 4.0	1.5, 2.0, 3.0	1.5, 2.0, 3.0	1.5, 2.0
POWER (WATTS)	.5	.5	.5	.5	.5	.5
SWITCH SPEED	6 MILLISECONDS PER STEP					
SWITCH LIFE	10,000,000 OPERATIONS					
CONTROL VOLTAGE	ATTENUATION INSERTED ± 12V, 370 MILLIWATTS PER STEP (OPTIONAL VOLT 5, 8, 9, 16, 26.5) ATTENUATION OUT TO +5 VOLT					
CONNECTORS	BNC STANDARD (OPTIONS SMA, TNC, N)					
WEIGHT	12 ounces .34 Kgs.					

MODEL	A	B	C
4440	4"	3 1/8"	3 1/2"
4460	10.16 cm	7.9 cm	8.9 cm
4447	10.16 cm	10.4 cm	11.7 cm
4487	5 1/8"	4 1/8"	4 5/8"
4450	13.0 cm	10.4 cm	11.7 cm
4457	13.0 cm	10.4 cm	11.7 cm

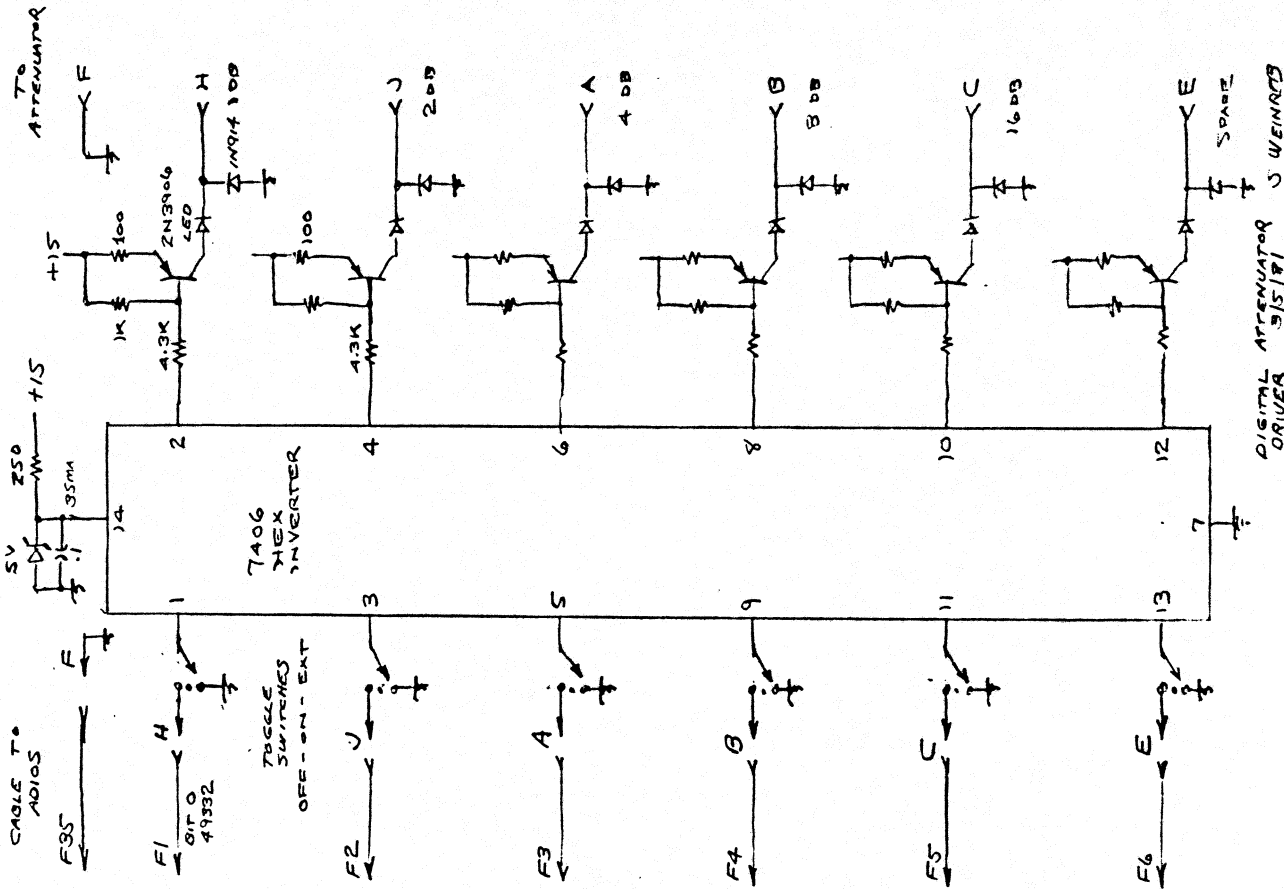
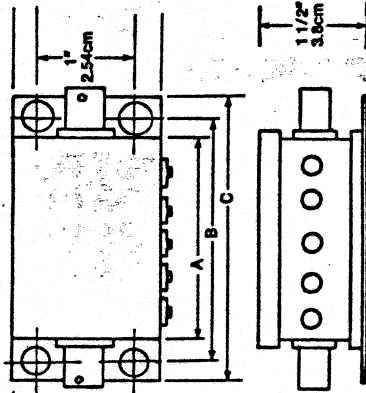

Appendix III. DETECTOR1 Program

Hardware Connection

A system such as that shown in Figure 1 must be connected thru the ADIOS interface to the Apple Computer. The ADIOS analog-input scaling toggle switches should be set for +/- (bipolar) mode with AIN full scale at 10 volts and BIN full scale at 1 volt.

Program Entry

The DETECTOR1 program must be on a disk along with auxiliary programs SHAPES (plotting symbols), HGR CHR GEN (to label plot), ADIOS-INITB (to initialize the A/D interface), and LOMEM: (to move program in memory). Type "RUN DETECTOR1" to load and run the program; the program will subsequently load in the auxiliary programs.

The program chooses integration time, COUNT = 800 MS, and settling time between attenuator steps, BLANK = 800 MS, for the square-law error measurement. These may be changed by typing the CTRL and E keys and then 192 when EDIT appears on the screen. The desired values are substituted in program line 192, the RETURN key is pressed, and "RUN" is typed to start the program with the new values. A similar procedure can be used on line 540 to change attenuator step values.

Program Operation

The program has several tasks; each is initiated by first typing the ESC key and then a number as described below. Any task may be terminated by typing "CTRL C."

ESC 1 - This starts a square-law error measurement. If the program has previously plotted square-law errors or noise measurements on the CRT, the screen may be first erased by typing "ESC 8."

ESC 2 - Pressing this after a square-law error measurement temporarily removes the plot and gives a table of results on the CRT.

ESC 3 - Brings back the square-law error plot after using ESC-2.

ESC 4 - This starts a detector noise measurement. The program first allows changing the number of samples, the attenuator DB setting, the integration time per sample in milliseconds, the IF bandwidth in MHz, or the plot scale in mV. Pressing RETURN will start the measurement.

ESC 6 - This prints the graph which is (or has been) on the CRT screen in a 5" wide format.

ESC 7 - This prints the graph double-size and rotated 90°.

ESC 8 - Erases graph memory.

ESC 9 - Prints a table of square-law error values.

Program Listing

A listing of the program as on March 26, 1981 follows:

01/23/81 0823.9

PROGRAM LENGTH= 11813 BYTES VARIABLES= 2459 BYTES
FREE MEMORY= 6207 BYTES
START=16385 LOMEM=28198 FREE=30577 STRING=36784 HIMEM=36864

```
100 REM     DETECTOR1 PROGRAM OF MARCH 26,1981 MEASURES SQUARE LAW  
      ERROR OF A DETECTOR  
110 REM     REQUIRED HARDWARE: 48K APPLE II+WITH DISK,CRT,PRINTER,CLOCK,AN  
      D ADIOS A/D INTERFACE  
  
120 REM     REQUIRED ON DISK: SHAPES (PLOTING SYMBOLS),HGR CHR GEN  
      (TO LABEL PLOT), ADIOS-INITB (TO INITIALIZE A/D INTERFACE), AND LOMEM:  
      (TO MOVE PROGRAM LOCATION)  
130 REM     NEXT MOVES PROGRAM START TO 16384  
140 PRINT CHR$(4);"BRUN LOMEM:"; & LOMEM: 16384  
145 REM     LOMEM IN A816,L160  
150 HIMEM: 36864  
160 REM     NEXT POKES RESTORE MEMORY AFTER 1013 SINCE LOMEM: CHANGED  
      VALUES  
170 POKE 1013,76: POKE 1014,12  
180 POKE 1015,151: POKE 1016,76  
190 POKE 1017,0: POKE 1018,151
```

```
192 CN = 800:BN = 0800: REM      DEFAULT COUNT AND BLANK TIMES IN MS
195 REM      NEXT ANNOUNCES PROGRAM
197 HGR : TEXT : HOME : SPEED= 255
200 PRINT "DETECTOR1 OF 3/26/81": PRINT
202 PRINT "MEASURES SQUARE-LAW ERROR AND DETECTOR NOISE AND DRIFT.
CONNECT DETECTOR TO AIN AND POWER METER TO BIN. ADIOS INTERNAL SWITCHES
MUST BE SET FOR +/- 10 VOLT MODE"
204 PRINT : PRINT "INTEGRATION PARAMETERS ARE COUNT=";CN;" AND BLANK=";BN
;". CHANGE THESE BY CONTROL-E 192. CHANGE ATTENUATOR STEPS BY CONTROL-E
540."
206 PRINT : PRINT "START SQUARE-LAW TEST BY ESC-1 OR NOISE/DRIFT TEST
BY ESC-4"
208 REM      NEXT LOADS CHARACTER GENERATOR IN A2048,L3328
210 PRINT CHR$(4);"BLOAD HGR CHR GEN"
220 REM      DEFINES CONTROL D FOR DOS PRINT
230 D$ = CHR$(4):DC$ = D$ + "CLOSE"
270 REM      NEXT LOADS PLOTTING SYMBOLS
275 PRINT D$;"BLOAD SHAPES"
280 POKE 232,191: POKE 233,31: REM      BLOADED SHAPES, A8127,L24
290 DIM A(050),U(200),P(050),E(050)
310 REM      NEXT INITIALIZES A/D INTERFACE AND SETS UP INTEGRATION CYCLE
320 PRINT D$;"BLOAD ADIOS-INITB"
330 REM      BLOADED 85 = $55 BYTES IN 7986 = $1F32
350 COUNT = CN:BLANK = BN
360 GOSUB 4100: REM      LOADS COUNT AND BLANK INTO ADIOS
420 REM      GOSUB 5300 TO TURN ON PRINTER
430 REM      CALL 1013 TURNS OFF PRINTER
450 POKE 33,40: REM      NORMAL TEXT WINDOW
480 REM      : CONSTANTS FOR SCALING
490 CA = 32:CB = 0.5:CC = 100:CE = 10:CD = 4.3429:CF = .23025851
492 CG = 1000
495 C1 = 100:C2 = 55.677:C3 = 4.605:C4 = 75:C5 = - 15
496 C8 = 278:C9 = 150
500 REM      CONSTANTS FOR DATA TRANSFER
510 MC = 3.2768:MU = 128:MK = 256:MM = 65536
520 REM      DEFAULT PARAMETER VALUES
530 FOR K = 0 TO 16: READ A(K): NEXT K
540 DATA 31,11,1,2,3,04,05,6,7,8,9,10,11,13,15,18,20
550 RESTORE
555 G = EXP (CF * (A(1) - A(0)))
600 REM      ROUND-OFF FUNCTIONS NEXT
610 DEF FN F0(X) = INT (X + CB)
615 DEF FN F1(X) = INT (CE * X + CB) / CE
620 DEF FN F2(X) = INT (CC * X + CB) / CC
625 DEF FN F3(X) = INT (CG * X + CB) / CG
630 REM      PLOTTING FUNCTIONS NEXT
640 DEF FN Y(E) = C4 + C5 * E
650 DEF FN X(U) = C2 * ( LOG (U) - C3)
700 DB = 11: GOSUB 4200: REM      SET ATTENUATOR TO REFERENCE LEVEL
800 REM      DEFAULT RMS NOISE PARAMETERS NEX
810 SAMPLES = 25:D1 = 11:TI = 1000:BW = 2:PS = 5
990 L = 1
998 N = 16
999 END
```

```
1100 GOSUB 3300: END
1200 TEXT : END
1300 POKE - 16304,0: POKE - 16301,0: UTAB (21): END
1400 REM NOISE TEST
1410 GOSUB 2000: END
1600 REM PRINT GRAPH
1605 INPUT "TYPE QUOTE MARK,COMMENT, AND (RETURN) " ;CM$
1610 GOSUB 5300: REM TURN ON PRINTER
1620 PRINT CM$
1625 POKE 1145,105: REM REGULAR SIZE
1630 CALL - 16038: REM FOR TRENDCOM 200
1640 CALL 1013: REM PRINTER OFF
1650 END
1700 REM BIG PLOT ON TRENDCOM 200 PRINTER
1705 INPUT "TYPE QUOTE MARK,COMMENT, AND (RETURN) " ;CM$
1710 GOSUB 5300
1720 POKE 2041,0: REM DEFEAT PAGE
1730 PRINT CM$
1740 POKE 1145,107: REM DOUBLE SIZE
1750 CALL - 16038: REM PLOT
1755 POKE 2041,68: REM RESET11" PAGE
1760 CALL 1013: END : REM

1800 HGR : TEXT : HOME : L = 1: END : REM ERASE GRAPHICS SCREEN
1900 GOSUB 5800: REM PRINT TABLE
1910 POKE - 16304,0: POKE - 16301,0: UTAB (21): END
2000 REM RMS NOISE MEASUREMENT
2010 SCALE= 1: ROT= 0
2015 TEXT : HOME
2018 PRINT
2019 HOME
2020 PRINT "PRESENT PARAMETERS ARE:"
2025 PRINT "(1) SAMPLES= " ;SA
2030 PRINT "(2) DB= " ;D1
2035 PRINT "(3) INTEGRATION= " ;TI ;" MS"
2040 PRINT "(4) BANDWIDTH= " ;BW ;" MHZ"
2042 PRINT "(5) PLOT SCALE,MU=" ;PS
2045 PRINT
2050 PRINT "CHANGE (1),(2),(3),(4),(5) OR (RETURN) TO START MEASUREMENT"
2055 GET J$
2060 ON VAL (J$) GOTO 2080,2100,2120,2130,2137
2070 GOTO 2140
2080 INPUT "(1) SAMPLES= " ;SA
2085 GOTO 2018
2100 INPUT "(2) DB= " ;D1
2105 GOTO 2018
2120 INPUT "INTEGRATION= " ;TI
2125 GOTO 2018
2130 INPUT "BANDWIDTH= " ;BW
2135 GOTO 2018
2137 INPUT "PLOT SCALE,MU= " ;PS
2138 GOTO 2018
2140 REM CHANGE COUNT AND BLANK IN ADIOS
2150 COUNT = TI:BLANK = 80
```

```
2160 GOSUB 4100: REM INITIALIZE ADIOS
2165 DB = A(0): GOSUB 4200: REM ZERO
2170 SG = .031 / SQR (BW * TI): REM THEORETICAL RMS
2175 REM DEF PLOT AXIS NEXT
2180 DEF FN Y1(W) = 75 - 74 * W / PS
2190 DEF FN X1(K) = 79 + 200 * (K - 1) / SA
2195 WL = - PS:WH = PS
2200 HGR
2207 FOR W = WL TO 1.1 * WH STEP WH
2210 HPLOT FN X1(1), FN Y1(W) TO FN X1(SA), FN Y1(W): NEXT W
2220 HPLOT FN X1(1), FN Y1(WL) TO FN X1(1), FN Y1(WH)
2230 HPLOT FN X1(SA), FN Y1(WL) TO FN X1(SA), FN Y1(WH)
2240 REM LABEL
2250 HCOLOR= 0: CALL 3072: PRINT CHR$(1): PRINT CHR$(17): HCOLOR=
3
2260 UTAB (2): PRINT D1;"DB"
2270 UTAB (4): PRINT TI;"MS"
2280 UTAB (6): PRINT BW;"MHZ"
2285 UTAB (8): PRINT SA;" SAMPLES"
2290 UTAB (10): PRINT "THEORETICAL"
2292 UTAB (11): PRINT "RMS="; FN F3(100 * SG);"% "
2300 UTAB (21): CALL 1013: POKE - 16301,0
2310 DB = A(0): GOSUB 4200
2315 K = 0
2320 DB = A(1): GOSUB 4200:U0 = AIN
2330 DB = D1: GOSUB 4200:UR = AIN
2340 UZ = (U0 - G * UR) / (1 - G)
2350 GOSUB 4200:UN = AIN - UZ
2355 REM USE HGR CHR GEN FOR UZ AND UN
2360 HCOLOR= 0: CALL 3072: PRINT CHR$(1): PRINT CHR$(17): HCOLOR=
3
2365 UTAB (12): PRINT "DR "; FN F2(UN * SG);"MU"
2370 UTAB (14): PRINT "UZ="; FN F2(UZ);"MU"
2380 UTAB (16): PRINT "UN="; FN F1(UN);"MU"
2385 UTAB (1): HTAB (12): PRINT FN F1(WH);"MU"
2390 UTAB (19): HTAB (12): PRINT FN F1(WL);"MU"
2400 UTAB (21): CALL 1013: POKE - 16301,0
2410 U1 = 0:U2 = 0:U3 = 0
2430 FOR K = 1 TO SA
2440 GOSUB 4200:U(K) = AIN - UZ
2445 DU = U(K) - UN
2450 U1 = U1 + DU:U2 = U2 + DU ^ 2
2460 U3 = U3 + K * DU
2470 P0 = (U(K - 1) - UN)
2472 P1 = (U(K) - UN)
2475 IF P0 > WH THEN P0 = WH
2476 IF P0 < WL THEN P0 = WL
2477 IF P1 > WH THEN P1 = WH
2478 IF P1 < WL THEN P1 = WL
```

```
2480 IF K < > 1 THEN H PLOT FN X1(K - 1), FN Y1(P0) TO FN X1(K),
  FN Y1(P1)
2490 DRAW 2 AT FN X1(K), FN Y1(P1)
2500 NEXT
2510 K0 = SA:K1 = SA * (SA + 1) / 2:K2 = K1 * (2 * SA + 1) / 3
2520 BB = (U3 - U1 * K1 / K0) / (K2 - K1 ^ 2 / K0): REM DRIFT SLOPE
2530 AU = U1 / K0 - BB * K1 / K0: REM AVERAGE ABOVE UN
2540 DR = 1000 * BB / (TI + 80): REM DRIFT IN MU/SEC
2550 MZ = U2 - 2 * AU * U1 - 2 * BB * U3 + AU ^ 2 * K0 + 2 * AU * BB
  * K1 + BB ^ 2 * K2
2555 AU = AU + UN
2560 RMS = ( SQR (MZ / K0))
2565 HCOLOR= 0: CALL 3072: PRINT CHR$ (1): PRINT CHR$ (17): HCOLOR=
  3
2568 UTAB (20)
2570 PRINT "RMS="; FN F3(RMS);"MU";" DRIFT="; FN F3(DR);" MU/S";"
  AU="; FN F2(AU);" MU"
2575 CALL 1013: POKE - 16301,0
2600 GOSUB 5300: REM TURN ON PRINTER
2605 PRINT
2610 PRINT "SAMP=";SA;" TIME=";TI;"MS RMS="; FN F3(RMS);"MU DRIFT=";
  FN F3(DR);"MU/S AU="; FN F2(AU);"MU"
2620 HOME : UTAB (21): CALL 1013: END
2800 REM INITIALIZE PLOT *****
2805 REM HANDLE LINE TYPE PARAMETER,L
2807 HCOLOR= 3
2810 ON L GOSUB 2820,2825,2830,2835,2840,2845
2815 GOTO 2850: REM LINE TYPE SET
2820 SH = 2: ROT= 0: SCALE= 1: RETURN
2825 SH = 2: ROT= 08: SCALE= 2: RETURN
2830 SH = 2: ROT= 0: SCALE= 2: RETURN
2835 SH = 1: ROT= 0: SCALE= 1: RETURN
2840 SH = 3: ROT= 00: SCALE= 1: RETURN
2845 SH = 3: ROT= 32: SCALE= 1: RETURN
2850 POKE - 16304,0: POKE - 16301,0: POKE - 16297,0
2890 L = L + 1
2895 IF L < > 2 THEN RETURN
2900 REM DRAW GRID AND LABEL
2905 POKE - 16301,0: REM TEXT/GRAPHICS
2918 HCOLOR= 3
2920 FOR J = - 5 TO 6 STEP 5
2930 H PLOT FN X(100), FN Y(J) TO FN X(15000), FN Y(J)
2940 NEXT J
2945 Q(1) = 100:Q(2) = 1000:Q(3) = 10000:Q(4) = 15000
2950 FOR J = 1 TO 4
2970 H PLOT FN X(Q(J)), FN Y( - 4.90) TO FN X(Q(J)), FN Y(5)
2980 NEXT J
3000 REM LABEL
3010 HCOLOR= 0
3020 CALL 3072: REM INIT HGR CHR GEN
3030 PRINT CHR$ (1); CHR$ (17)
3035 HCOLOR= 3
3040 UTAB (1): HTAB (2): PRINT "+5%"
3045 UTAB (18): HTAB (2): PRINT "-5%"
3050 UTAB (20): HTAB (1): PRINT ".1"
3060 UTAB (20): HTAB (18): PRINT "1 VOLT"
3070 UTAB (20): HTAB (36): PRINT "10"
3080 UTAB (20): HTAB (39): PRINT "15"
3150 UTAB (21)
3160 CALL 1013
3170 POKE - 16301,0
```

```
3180 J1 = FN Y(4):J3 = FN Y( - 4)
3185 J2 = J1 - FN Y(3)
3190 FOR J = J3 TO J1 STEP J2
3195 FOR K = 0 TO 279 STEP 8
3200 HLOT K,J
3210 NEXT K: NEXT J
3220 RETURN
3299 REM
```

```
3300 REM MEASUREMENT TASK
3302 COUNT = CN:BLANK = BN
3304 GOSUB 4100: REM LOADS COUNT AND BLANK INTO ADIOS
3310 DB = A(0): GOSUB 4200
3320 GOSUB 2900
3330 DB = A(0): GOSUB 4200
3350 DB = A(1): GOSUB 4200
3360 U(0) = AIN:P(0) = BIN
3370 PRINT FN F1(AIN), FN F1(BIN)
3400 DB = A(2): GOSUB 4200
3410 U(1) = AIN:P(1) = BIN
3420 PRINT FN F1(AIN), FN F1(BIN)
3430 UZ = (U(0) - G * U(1)) / (1 - G)
3440 PZ = (P(0) - G * P(1)) / (1 - G)
3450 S = (U(1) - UZ) / (P(1) - PZ)
3460 PRINT "UZ= "; FN F2(UZ);" PZ= "; FN F2(PZ);" S= "; FN F2(S)
3500 FOR K = 2 TO N
3510 DB = A(K + 1): GOSUB 4200
3520 U(K) = AIN:P(K) = BIN
3530 E(K) = C1 * (U(K) - UZ - S * (P(K) - PZ)) / U(K)
3540 PRINT A(K); TAB( 10); FN F2(U(K)); TAB( 20); FN F2(P(K)); TAB(
 30); FN F2(E(K));"%
3548 XX = FN X(U(K)):YY = FN Y(E(K))
3550 IF XX < 0 THEN XX = 0
3552 IF XX > C8 THEN XX = C8
3554 IF YY < 0 THEN YY = 0
3556 IF YY > C9 THEN YY = C9
3560 DRAW SH AT XX,YY
3570 REM DRAW
3580 NEXT K
3610 DB = 11: GOSUB 4200
3620 RETURN : REM
```

```
4100 REM LOAD COUNT,BLANK IN ADIOS
4110 CS = 10 / COUNT
4115 CT = 2 * CS:CZ = 10000
4120 CX = COUNT / 10:BX = BLANK / 10
4130 CH% = CX / 256:BL% = BX / 256
4140 REM NEXT LOADS COUNT AND BLANK TIMES INTO ADIOS
4150 POKE 7988,CX - 256 * CH%: POKE 7989,CH%
4160 POKE 7990,BX - 256 * BL%: POKE 7991,BL%
4170 CALL 8018: REM STARTS ADIOS
4180 RETURN
4200 REM DATA TRANSFER ROUTINE WITH PARAMETERS DB (ATTENUATION),AIN,
AND BIN
4201 REM GOTO 4700 :REM THIS IS TO GENERATE A TEST INPUT TO PROGRAM
4205 REM NEXT 4 LINES TO SET UP 9513
4210 POKE 49342,20: REM ADDRESSES 9513 HD4
4220 ZZ = PEEK(49334): REM ZZ IS DUMMY
4230 POKE 49334,172: REM CALL BIT SET HIGH
4240 IF PEEK(49335) < 128 THEN 4500
4250 WAIT 49335,128,128: REM WAIT UNTIL DATA READY BIT =0 AT BLANK
```

TIME START

```
4260 POKE 49335,128: REM RESET DATA READY BIT
4280 DB% = DB
4290 POKE 49332,DB%
4300 POKE 49342,20: REM ADDRESS 9513 TO OUTPUT LSHORD OF BIN
4310 BIN = PEEK (49334) + MK * PEEK (49334)
4320 POKE 49342,21: REM ADDRESS 9513 TO OUTPUT MSWORD OF BIN
4330 BIN = BIN + MM * PEEK (49334)
4335 BIN = CT * BIN - CZ
4340 POKE 49342,18: REM ADDRESS 9513 TO OUTPUT LSHORD OF AIN
4350 AIN = PEEK (49334) + MK * PEEK (49334)
4360 POKE 49342,19: REM ADDRESS 9513 TO OUTPUT MSWORD OF AIN
4365 AIN = AIN + MM * PEEK (49334)
4367 AIN = CT * AIN - CZ
4370 POKE 49342,20: REM ADDRESS 9513 HD4
4380 ZZ = PEEK (49334): REM DUMMY PEEK
4390 POKE 49334,168: REM CLEAR CALL BIT
4400 RETURN
4500 REM TURN ON MISSED DATA LIGHT
4510 POKE 49342,18: REM ADDRESS HOLD1
4520 ZZ = PEEK (49334): REM DUMMY
4530 POKE 49334,172: REM CLOCKS MISSED DATA ONE-SHOT
4540 POKE 49342,18
4550 ZZ = PEEK (49334)
4560 POKE 49334,168: REM CLEARS MISSED DATA CLOCK
4570 POKE 49335,0: REM CLEAR FLAG
4580 GOTO 4250: REM
```

4590 REM

```
4700 AIN = 20 + EXP (CF * (41 - DC)) + .05 * K + 2.4 * ( RND (K) -
.5)
4705 DC = DB
4707 BIN = .1 * AIN
4710 RETURN
4800 REM SETS T$ TO TIME
4805 YR$ = "81"
4810 D$ = CHR$ (4)
4820 PRINT D$;"IN#4"
4830 PRINT D$;"PR#4"
4840 INPUT " ";T$
4850 CALL 1013
4870 DT$ = LEFT$ (T$,5) + "/" + YR$ + " "
4872 SC$ = MID$ (T$,13,2)
4874 EM = .1 * INT ( VAL (SC$) / 6)
4876 EM$ = STR$ (EM)
4880 TM$ = MID$ (T$,7,2) + MID$ (T$,10,2) + EM$ + " "
4890 RETURN
5300 REM TURNS ON TRENDCOM 200 PRINTER
5310 REM :GOTO 5400: REM FOR APPLE PRINTER
5315 PR# 1: PRINT CHR$ (0): REM FIRST CHARACTER NOT PRINTED
5320 POKE 1913,6: POKE 1785,72: REM MARGINS
5330 POKE 1657,80: REM LINE LENGTH
5340 RETURN
5400 REM TURN ON APPLE PRINTER
5410 PRINT CHR$ (4);"PR#1"
5420 Q$ = CHR$ (17): REM PRINT Q$ TO DUMP GRAPHICS
5430 POKE - 12524,0: REM BLACK ON WHITE PLOT
5440 POKE - 12528,7: REM DARK PRINT
5450 POKE - 12527,8: REM LEFT MARGIN
5460 RETURN
```



```
5800 REM PRINTS TABLE
5810 GOSUB 5300: REM TURN ON PRINTER
5820 HOME : PRINT CHR$(9);"N": REM DISABLE CRT
5830 POKE 33,80: REM SET MARGIN
5835 PRINT "UZ="; FN F2(UZ); TAB( 15);" PZ="; FN F2(PZ); TAB( 30);"S=";
FN F2(S)
5840 PRINT "ATTEN"; TAB( 15);"DET MU"; TAB( 30);"MTR MU"; TAB( 45);"ERROR
"
5850 FOR K = 0 TO N
5860 PRINT A(K); TAB( 15); FN F2(U(K)); TAB( 30); FN F2(P(K)); TAB(
45); FN F2(E(K));"%"
5870 NEXT : POKE 33,40
5880 PRINT CHR$(9);"I": REM ENABLE CRT
5890 CALL 1013
5900 POKE - 16301,0
5910 RETURN : REM

6000 REM FORMATTED LIST
6002 GOSUB 4800: REM GET TIME
6005 POKE 33,33
6010 GOSUB 5300: REM TURN ON PRINTER
6025 DEF FN CT(AD) = PEEK (AD) + 256 * PEEK (AD + 1)
6028 SR = FN CT(103)
6030 LM = FN CT(105);FR = FN CT(109)
6035 HM = FN CT(115);ST = FN CT(111)
6043 PRINT : PRINT DT$,TM$: PRINT
6045 PRINT "PROGRAM LENGTH= ";LM - SR;" BYTES          VARIABLES= ";HM
- ST + FR - LM;" BYTES"
6050 PRINT "FREE MEMORY= ";ST - FR;" BYTES"
6051 PRINT "START=";SR;" LOMEM=";LM;" FREE=";FR;" STRING=";ST;" HIMEM=";H
M
6055 PRINT
6060 LIST
6065 CALL 1013
6070 END
```

Appendix IV. Noise Analysis

Given a sequence of samples, $V(K)$, for $K = 1$ to SA , , we wish to compute the linear function, $A + B * K$, which minimizes the total mean square deviation, M , from $V(K)$

$$M = \sum_{k=1}^{SA} [V(K) - A - B * K]^2 \quad (IV.1)$$

The minimization is performed in the usual manner by setting the derivatives of M with respect to A and B equal to zero and then solving the two simultaneous linear equations for A and B . The result is expressed in terms of six quantities which are defined below, all summations being for $K = 1$ to SA :

$$V1 = \sum V(K) \quad (IV.2)$$

$$V2 = \sum V^2(K) \quad (IV.3)$$

$$V3 = \sum K*V(K) \quad (IV.4)$$

$$K\emptyset = \sum 1 = SA \quad (IV.5)$$

$$K1 = \sum k = SA*(SA + 1)/2 \quad (IV.6)$$

$$K2 = \sum k^2 = K1*(2SA + 1)/3 \quad (IV.7)$$

$$A = V1/K\emptyset - B*K1/K\emptyset \quad (IV.8)$$

$$B = (V3 - V1*K1/K\emptyset)/(K2 - K1^2/K\emptyset) \quad (IV.9)$$

$$M = V2 - 2*A*V1 - 2 * B*V3 + A^2*K\emptyset + 2*A * B*K1 + B^2*K2 \quad (IV.10)$$

The rms deviation, RMS, and drift rate are then given by,

$$\text{RMS} = \sqrt{M/K\emptyset} \quad (\text{IV.11})$$

$$\text{DR} = B/(SA*T1) \quad (\text{IV.12})$$

where T1 is the time interval of one sample.

To ease computational accuracy requirements, a voltage, VN, equal to the value of an initial sample is subtracted from the measured voltage before computation of the sums IV.2-4. The same quantity is then added to A to give the average value of the sequence with drift removed.

The theoretical rms deviation of the output of a square-law detector driven by noise of bandwidth, BW, is given in % as $100*/\sqrt{BW*T1}$ or as a voltage value, $VN/\sqrt{BW*T1}$. These values are printed by the program for comparison with measured values. It should be noted that the % accuracy of a rms deviation measurement is equal to $100/\sqrt{SA}$; thus, for SA = 50 a rms accuracy of 14% or a peak-to-peak error of $\pm 30\%$ is expected.