

NATIONAL RADIO ASTRONOMY OBSERVATORY
CHARLOTTESVILLE, VIRGINIA

ELECTRONICS DIVISION INTERNAL REPORT No. 211

MILLIMETER WAVELENGTH FREQUENCY MULTIPLIERS

JOHN W. ARCHER

JANUARY 1981

NUMBER OF COPIES: 150

MILLIMETER WAVELENGTH FREQUENCY MULTIPLIERS

by

John W. Archer

National Radio Astronomy Observatory^{*}

2015 Ivy Road

Charlottesville, Virginia 22903

ABSTRACT

Mechanically tuneable, millimeter wavelength frequency doublers typically exhibiting 10% conversion efficiency at any output frequency in the range 100 - 260 GHz have been fabricated. Output power varies from 10 mW at 100 GHz to 6 mW at 260 GHz, with a fixed tuned instantaneous 1 dB bandwidth typically 5% of the center frequency. A frequency tripler to 215 GHz output frequency is also described. For this device, a mechanically tuneable 3 dB bandwidth of 210 GHz to 240 GHz was obtained, with a peak conversion efficiency of 6% at 4.8 mW output power.

* The National Radio Astronomy Observatory is operated by Associated Universities, Incorporated, under contract with the National Science Foundation.

INTRODUCTION

Sources of millimeter wavelength power for heterodyne receiver local oscillator applications at wavelengths shorter than 3mm have conventionally been expensive, short-lived klystrons. An alternate approach is to use efficient, broadband frequency multipliers in conjunction with more reliable, lower frequency oscillators to provide power in the frequency range 100 GHz and above. The availability of high cut-off frequency Schottky barrier diodes, with high breakdown voltages, has recently rendered the latter alternative feasible. This paper reports the development of mechanically tuneable varactor frequency multipliers, which provide adequate output power for local oscillator applications in mm-wave heterodyne receivers operating at frequencies in the 100 - 260 GHz range.

The paper commences with a brief outline of the basic microwave circuit requirements for the implementation of efficient frequency multipliers, then relates these parameters to the mechanical construction of the devices. Microwave scale modelling techniques, in conjunction with computer-aided analysis of the behavior of the non-linear varactor impedance, were used to optimize the electrical design of the multipliers. This procedure is outlined and then, finally, the measured performance of the frequency multipliers is presented.

IMPLEMENTATION

Any non-linear impedance, when driven by a sinusoidal signal, produces power at the harmonics of the fundamental pump frequency. A device, such as an abrupt junction varactor, whose capacitance, $C_j(v)$, decreases non-linearly with increasing reverse voltage, v , according to the relationship^[1,2,3] (not exact for appreciable forward bias; ϕ is a constant which

is approximately, but not exactly, the junction contact potential)

$$C_j(v) = C_j(0) \left(\frac{\phi}{\phi - v} \right)^{1/2}$$

is theoretically capable of harmonic conversion efficiencies approaching 100%. The principal theoretical limitation on the attainable efficiency is the presence of an unavoidable series resistance (R_s) in the practical varactor diode. A useful figure of merit, for a varactor diode, in terms of its series resistance and the maximum available change in its junction capacitance, is "the dynamic cutoff frequency" [1,2,3]

$$f_c = \frac{S_{\max} - S_{\min}}{2\pi R_s}$$

where S_{\max} , S_{\min} are the maximum and minimum values of the junction elastance (inverse capacitance) measured over one cycle of the pump waveform.

The varactor diode is usually mounted in a microwave circuit, which should ideally satisfy a number of requirements if the frequency multiplier is to exhibit high conversion efficiency. Firstly, it is impossible for the abrupt junction varactor (except in the case of the frequency doubler) to generate harmonic power with varactor currents flowing only at the input and output frequencies. In order to generate harmonics higher than the second, currents must be allowed to flow in the varactor circuit at intermediate harmonics - such intermediate harmonics are known as idlers. For high conversion efficiency, the idler circuits should possess low loss.

The input, output and idler circuits should only be coupled electrically through the non-linear reactance of the varactor. Furthermore, the input and output circuits should be conjugately matched to the time average of the dynamic impedance of the varactor at their respective harmonic frequencies. Finally, currents should only flow in the varactor circuit at input, output and idler frequencies - the device should be open circuit at the other harmonics.

If these conditions are satisfied, for a given multiplier, the conversion efficiency is maximized for a unique value of output circuit load impedance. This impedance and the maximum value of the efficiency are functions of the input drive level and the varactor characteristics. In particular, the conversion efficiency (η_d) of the ideal varactor multiplier may be written as^[3]:

$$\eta_d = \exp(-\alpha f_{\text{out}}/f_c)$$

where f_{out} is the output frequency,

and α is a parameter related to the harmonic order of the output and to the input drive level.

Typically, for multipliers driven so that the RF voltage swings between $-V_B$ and 0, α is about 10 for a doubler and about 16.5 for a tripler with second harmonic idler.

The crossed waveguide mount used for the multipliers described here, and illustrated in Figure 1, was designed to approximately satisfy the foregoing requirements over relatively broad bandwidths. Power incident in the full height input waveguide (WR-12 for the 100 - 170 GHz output device, WR-8 for 170 - 260 GHz) is fed via a tuneable transition^[9,10] to a suspended substrate stripline low pass filter (on .003" thick crystal-

line quartz). The seven section filter^[4] passes the fundamental frequency with low loss but is cutoff for higher order harmonics. The stripline channel dimensions are such as to suppress higher order mode propagation at frequencies up to and including the third harmonic of the pump^[5].

The low pass filter, with correctly chosen characteristic impedance and lengths for the elements, transforms the impedance of the pumped varactor at the input frequency to a convenient value at the plane of the waveguide to stripline transition. With careful design of the transition, matching of the input circuit over broad bandwidths is possible by varying the waveguide backshort position.

The varactor diode chip is mounted (contacted with a .0005" diameter whisker) in a half height waveguide cavity (WR-7 for the 100 - 170 GHz doubler, WR-4 for 170 - 260 GHz), along with an adjustable tuning backshort. DC bias is brought to the diode via a coaxial bias line. The center conductor of the bias line is a length of .001" diameter gold wire bonded at one end to the low pass filter. The line is single moded and a quarter wavelength long at the input center frequency, and is effectively short-circuited at its input end, at pump frequencies, by a 100 fF quartz dielectric capacitor.

For doublers, the waveguide cavity in which the diode is mounted is connected via a quarter-wave step impedance transformer to the full height output waveguide. For efficient operation of the tripler, however, a suitable second harmonic idler termination must be provided. This is implemented in the present design by terminating the diode cavity (reduced height WR-7) at approximately a half wavelength from the plane of the diode with an inhomogeneous quarter-wave step transformer to the third harmonic output waveguide (WR-3). Since the output waveguide is cutoff at the second harmonic

of the pump, the diode cavity is effectively short-circuited a half wavelength from the diode at this frequency. The idler requirement can, therefore, be seen to be approximately satisfied over a relatively narrow band about the frequency at which the varactor diode is short-circuited by the resonance of this termination with the whisker inductance.

The varactor diodes used in these devices were notch-front GaAs Schottky barrier diodes fabricated by R. Mattauch of the University of Virginia. Monsanto epitaxial material was used, Silicon doped, with an epitaxial layer thickness of $1.5 \mu\text{m}$ and a doping density of $2.6 \times 10^{16} \text{ cm}^{-3}$. The epi-layer to substrate transition zone for these diodes is of the order of 1500\AA . The diodes used for devices with output frequencies in the range 100 - 170 GHz had anode diameters of $5 \mu\text{m}$ yielding a zero bias capacitance of 21 fF, a DC series resistance of 8Ω and a reverse breakdown voltage of 14.5 volts. For the 170 - 260 GHz frequency range, the diodes were typically $4 \mu\text{m}$ in diameter, with a zero bias capacitance of 15 fF, a DC series resistance of 6Ω and a reverse breakdown voltage of 14 volts. These parameters yield dynamic cutoff frequencies of about 3000 GHz and 5300 GHz respectively.

For reverse bias voltages to within two volts of the breakdown limit, the capacitance versus voltage law for these devices closely follows the inverse half power law typical of abrupt junction varactors. However, as the bias voltage approaches the breakdown limit, the change in capacitance with increasing voltage is less than expected. The depletion layer has, under this condition, extended through the epitaxial material and into the transition region where the doping grades from that of the epi-layer to that of the substrate. The variation in doping with penetration in this region results in a modified relationship between the applied voltage, the depletion region width, and, consequently, the diode capacitance.

Theoretical doubling efficiencies for a lossless ideal multiplier (undesired harmonics open circuited at the diode) range from about 70% at 100 GHz (5 μm diode) to 60% at 260 GHz (4 μm diode) and, at 230 GHz, the theoretical tripling efficiency for the second diode is 45%. The optimum characteristics of a diode for use at a given frequency in a given mount are determined with the aid of the analysis outlined in the following section.

DESIGN OPTIMIZATION

Although the simplified theory for the performance of an ideal varactor multiplier is useful as a guide in evaluating the relative merits of the choice of a particular varactor diode for use at a given frequency, it does not accurately represent the practical device. One approach to the analysis of the practical multiplier is to construct a scale model^[6], which operates at much lower frequencies, where measurement of circuit impedances is feasible using a network analyzer. Combining the measured impedances with dynamic non-linear analysis techniques^[7], in order to determine the varactor diode voltage and current waveforms, yields a more accurate picture of the behavior of a given varactor multiplier mount.

Two scale models of the doubler mount, operating at a center frequency of 2.5 GHz, were fabricated in the present case, the first with a full height waveguide diode cavity and the second with the height reduced to one half of its standard value. Using these models, the embedding impedance presented to the varactor diode was determined as a function of frequency and diode cavity backshort position for frequencies up to and including the sixth harmonic of the fundamental pump frequency. These results indicate that, in

either case, the diode is not terminated in a pure reactance at the third harmonic and above, allowing undesired power flow at frequencies other than the fundamental and second harmonic. However, the inductive reactance of the embedding impedance increases with frequency, resulting in a progressively poorer match between the embedding circuit and the diode impedance at the higher harmonics. As a consequence, the coupling of harmonic power to the lossy higher order terminations would be expected to decrease with increasing harmonic frequency.

A large signal non-linear analysis of the pumped varactor^[7] was carried out at a frequency of 70 GHz, assuming that the measured scale model embedding impedances are those of the millimeter-wavelength mount. The expected instantaneous voltage and current waveforms of the diode were derived, with the diode DC bias voltage set so that the instantaneous RF voltage across the varactor diode did not exceed its reverse breakdown voltage. The analysis was undertaken for both the 4 μm and 5 μm diameter diodes described previously. Figure 2 shows the average diode forward current, the predicted maximum second harmonic conversion efficiency and the real and imaginary parts of the diode impedance at the fundamental, as a function of pump power for the 5 μm diameter diode in the reduced height waveguide mount. Curves with similar characteristics have been derived for the 4 μm diode. The efficiency is maximized, for a given frequency and input power level, when the backshort position is such as to result in a purely resistive termination of the diode effective resistance at the second harmonic, i.e., the average diode capacitance is resonated out at the second harmonic by the reactive part of the embedding impedance.

Note that as pump power is increased above the condition for which zero forward DC bias current is drawn, the conversion efficiency decreases and the average diode resistance increases. These effects occur as a result of the diode drawing forward current over a portion of the pump cycle. During this period of forward conduction, the non-linear capacitance of the junction is shunted by a resistance whose value depends strongly on the forward current waveform. The presence of this additional resistance gives rise to the noted effects.

Of the various mounts and diodes studied, the reduced height waveguide version with the 5 μm diode was found, for two reasons, to be a more desirable design at a pump frequency of 70 GHz. Firstly, in the reduced height mount, the real part of the impedance presented to the varactor at resonance at the second harmonic is more nearly equal, when compared with the full height mount, to the effective dynamic resistance of the diode at this frequency. This results in a better impedance match between the varactor diode and the waveguide of the cavity and, hence, a better conversion efficiency. Secondly, at the fundamental, with the 5 μm diode in the reduced height mount, the reactive part of the impedance of the diode circuit is small compared with its real part. That is, the average diode capacitance and the whisker inductance are close to series resonance at the pump frequency. In the reduced height mount with the 4 μm diode, or in the full height mount using either diode, this resonance does not occur near 70 GHz. This condition results in a theoretical input impedance for the complete pump circuit, at the plane of the waveguide to strip-line transition, which has the frequency response and magnitude shown in Figure 3. Also shown in Figure 3 is the theoretical output impedance of

the waveguide to stripline transition in the pump waveguide, as a function of frequency and backshort position.

It is clear from Figure 3, that, in order to achieve efficient power transfer from input waveguide to varactor diode, the real part of the diode input impedance must be about 45 ohms. However, for this to be the case, the diode must be overdriven, resulting in a degradation in conversion efficiency. Hence, there must be a trade-off between achieving a reasonable impedance match in the input circuit and minimizing the degradation in conversion efficiency due to overdriving. The actual efficiency in a practical multiplier would, therefore, be expected to be less than the value given in Figure 2. Nevertheless, the impedance relationships in the input circuit are such that good performance over quite broad bandwidths should be expected.

PERFORMANCE MEASUREMENTS

Figure 4 shows the typical performance obtained with doublers designed to operate in the 100 - 170 GHz range, using the 5 μm diameter varactor diodes as the active element. The results show the output power and conversion efficiency as a function of frequency, with a constant input power of 80 mW, for mechanically tuneable, narrowband and broadband models of the doubler. The mechanically tuneable bandwidth and the center frequency of the device can be controlled to a moderate extent by the modification of the input waveguide coupling probe dimensions. For the narrowband version, the peak output power was 16 mW at 145 GHz, corresponding to a conversion efficiency of 20%. The mechanically tuneable 3 dB bandwidth was 18 GHz, with a fixed tuned 1 dB bandwidth of 8 GHz. The broadband device tuned over the range 100 - 170 GHz with output power greater

than 8 mW, corresponding to a conversion efficiency of more than 10%. At any frequency within this tuning range the fixed tuned instantaneous 1 dB bandwidth was greater than 7% of the output center frequency.

Figure 5 shows equivalent results for a second, physically scaled version of the narrowband doubler designed to operate in the 170 - 260 GHz range. When mechanically tuned over this range, the device exhibited greater than 6 mW output power for 80 mW input power, corresponding to a minimum conversion efficiency of 7.5%. The maximum output power obtained was 21.5 mW, corresponding to a peak conversion efficiency of 27%. At any output frequency, the fixed tuned instantaneous 1 dB bandwidth was typically 6%.

Figure 5 also presents the performance results for a tripler, with output frequency centered at 215 GHz. At the center frequency, the maximum output power is 4.8 mW for 80 mW input, corresponding to a conversion efficiency of 6%. The mechanically tuned 3 dB bandwidth is seen to be about 25 GHz, while the fixed tuned instantaneous 1 dB bandwidth was typically 3 GHz at a center frequency of 215 GHz.

HIGHER ORDER HARMONIC SPECTRUM

The output spectrum of the multipliers described above has been investigated in order to determine the power distribution amongst harmonic frequencies higher than the desired component. A quasi-optical interferometric technique was developed, which enables the estimation of the power at frequencies up to and including the sixth harmonic of the pump.

Consider a polarizing interferometer of the type described by Martin and Puplett^[8]. This type of interferometer exhibits very broad bandwidth, limited only at high frequencies by the wire spacing of the polarizing grids (upper limit, f_u , is approximately $150d^{-1}$ GHz, where d is the wire spacing in mms). The power transfer function, at frequencies $f < f_u$, of such a device is given by:

$$g(\Delta L, f) = \frac{1}{2} \left[1 \pm \cos\left(\frac{2\pi f}{c} \Delta L\right) \right]$$

where ΔL is the path difference and the sign is taken positive for the resolving polarizer parallel to the input polarization or negative for the resolver orthogonal to the input polarization.

The output voltage of the frequency multiplier may be expanded in a Fourier series in the following manner:

$$v(t) = \sum_{n=-\infty}^{\infty} \alpha_n \exp(j2\pi n f_0 t)$$

where f_0 is the fundamental pump frequency.

This function has power spectrum

$$S(f) = 2\pi \sum_{n=-\infty}^{\infty} |\alpha_n|^2 \delta(f - n f_0)$$

Thus, the output power spectrum from the interferometer for frequencies $f < f_u$ and parallel polarizers is given by:

$$S_0(f) = \pi \sum_{n=-\infty}^{\infty} \left[1 + \cos\left(\frac{2\pi f_0 n}{c} \Delta L\right) \right] |\alpha_n|^2 \delta(f - n f_0)$$

Suppose now that the output power is measured with a broad band power meter, with response $p(f)$. Then the power meter reading, $P_0(\Delta L)$, will be:

$$P_0(\Delta L) = \pi \sum_{n=-\infty}^{\infty} p(nf_0) \left[1 + \cos \left(\frac{2\pi f_0 n}{c} \Delta L \right) \right] |\alpha_n|^2$$

The Fourier transform of $P_0(\Delta L)$, with respect to ΔL , therefore, gives, directly, information about the power spectrum of $v(t)$.

Table 1 presents information about the harmonic spectrum of the multipliers described in this paper, measured using the above technique. Typically, power in unwanted higher order harmonics is at least 10 dB below the desired output components, when the multiplier is adjusted for optimum doubling (or tripling) performance at a given frequency.

CONCLUSION

The results presented in this paper show that efficient broadband frequency multipliers can be fabricated for the 100 - 260 GHz frequency range. Efficiencies for a given doubler operating in this range are typically 10% or greater over a mechanically tuneable bandwidth corresponding to a full waveguide band. Corresponding peak output powers, being of the order of 8 mW, are adequate for most applications as local oscillator sources in millimeter wavelength heterodyne receivers. The results provide encouragement for the further development of waveguide mounted doublers and triplers operating to 350 GHz. Above this frequency, waveguide techniques become impractical mechanically and a quasi-optical approach to multiplier design appears to be indicated.

ACKNOWLEDGMENTS

The author wishes to acknowledge useful discussions with Dr. S. Weinreb and, during the early stages of the work, with Dr. M. Pospieszalski. The provision of the varactor diodes by Dr. R. Mattauch of the University of Virginia is also gratefully acknowledged.

REFERENCES

1. Penfield, P. and Rafuse, R. P., "Varactor Applications," MIT Press, Cambridge, Mass., 1962.
2. Scanlan, J. O., "Analysis of Varactor Harmonic Generators," Advances in Microwaves, Young, L., editor, Chap. 4, Academic Press, N.Y., 1967.
3. Gewartowski, J. W., "Microwave Semiconductor Devices and Their Circuit Applications," Watson, H. A., editor, Chap. 8, McGraw Hill, 1969.
4. McMaster, T. F., Schneider, M. V., and Snell, W. W., "Millimeter Wave Receivers With Subharmonic Pump," IEEE, MTT-24, No. 12, pp. 948 - 952, Dec. 1976.
5. Schneider, M. V. and Glance, B. S., "Suppression of Waveguide Modes in Strip Transmission Lines," Proc. IEEE, Vol. 62, pp. 1184, Aug. 1974.
6. Stratton, J. A., "Electromagnetic Theory," pp. 488 - 490, McGraw Hill, N.Y., 1941.
7. Held, D. N., and Kerr, A. R., "Conversion Loss and Noise of Microwave and Millimeter Wave Mixers: Part I - Theory," IEEE, MTT-26, No. 2, pp. 49 - 61, Feb., 1978.
8. Martin, D. H. and Puplett, E., "Polarized Interferometric Spectrometry For the Millimeter and Submillimeter Spectrum," Infrared Physics, Vol. 10, pp. 105 - 109, 1969.
9. Collin, R. E., "Field Theory of Guided Waves," Chapter 7, p. 258, McGraw Hill, New York, 1960.
10. Knerr, R. H., "A New Type of Waveguide To Stripline Transition," IEEE, MTT-16, No. 3, pp. 192 - 194, March 1968.

TABLE 1

SOME SAMPLE MEASUREMENTS OF MULTIPLIER OUTPUT
HARMONIC CONTENT. PUMP POWER CONSTANT AT 80 mW.

Pump Frequency GHz	Relative Power at Harmonic Frequencies (dB)					Device Type
	f_p	$2 f_p$	$3 f_p$	$4 f_p$	$5 f_p$	
70.0	0	-10 ± 0.2	-19 ± 0.5	-24 ± 2	-30 ± 3	100 - 170 GHz Output Doubler
70.0	0	< -30	-12 ± 0.5	-22 ± 2	-30 ± 3	210 - 240 GHz Output Tripler
100.0	0	-10.6 ± 0.4	-23 ± 3	-	-	170 - 260 GHz Output Doubler

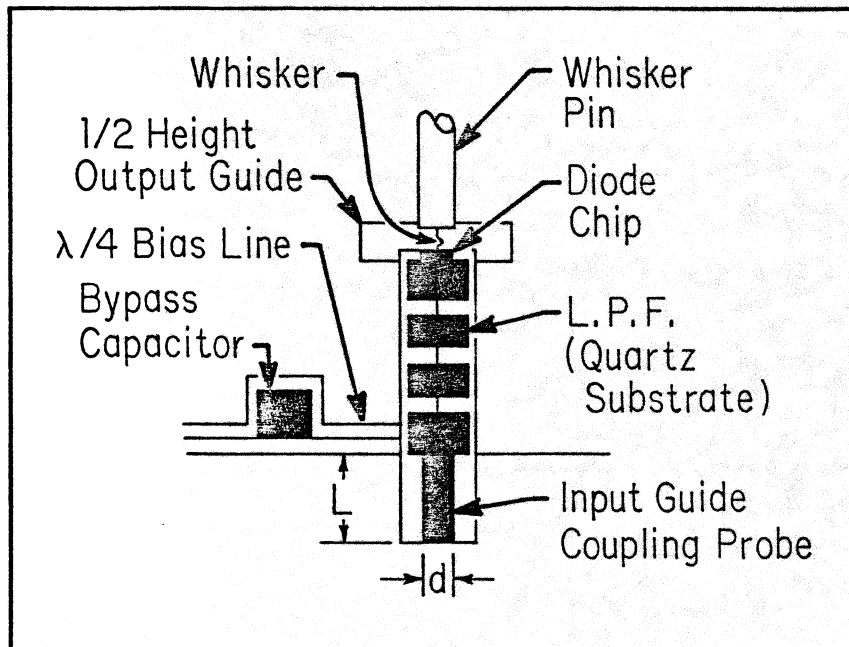

Inset for Figure 1

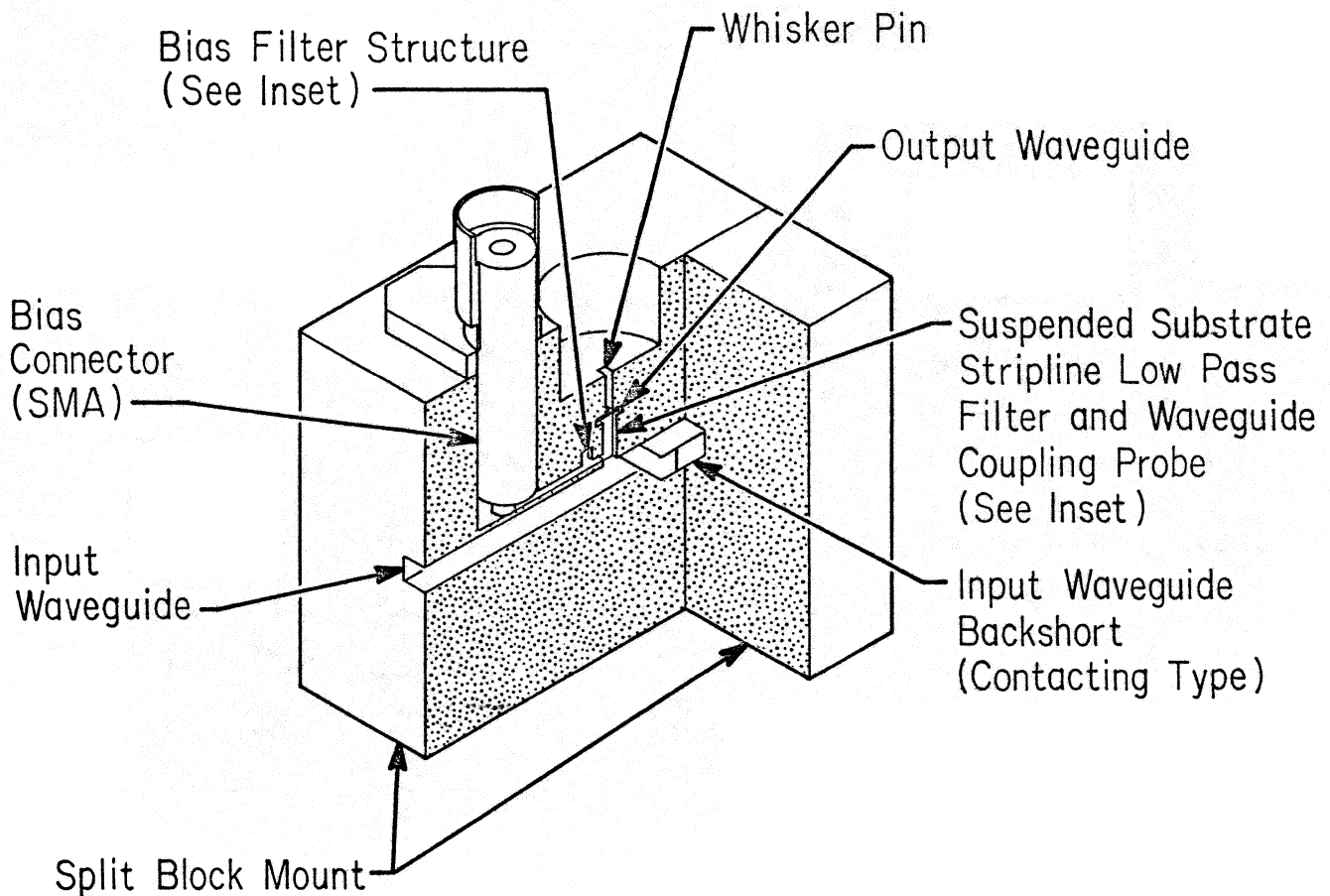

Figure 1: The NRAO crossed waveguide frequency multiplier mount.

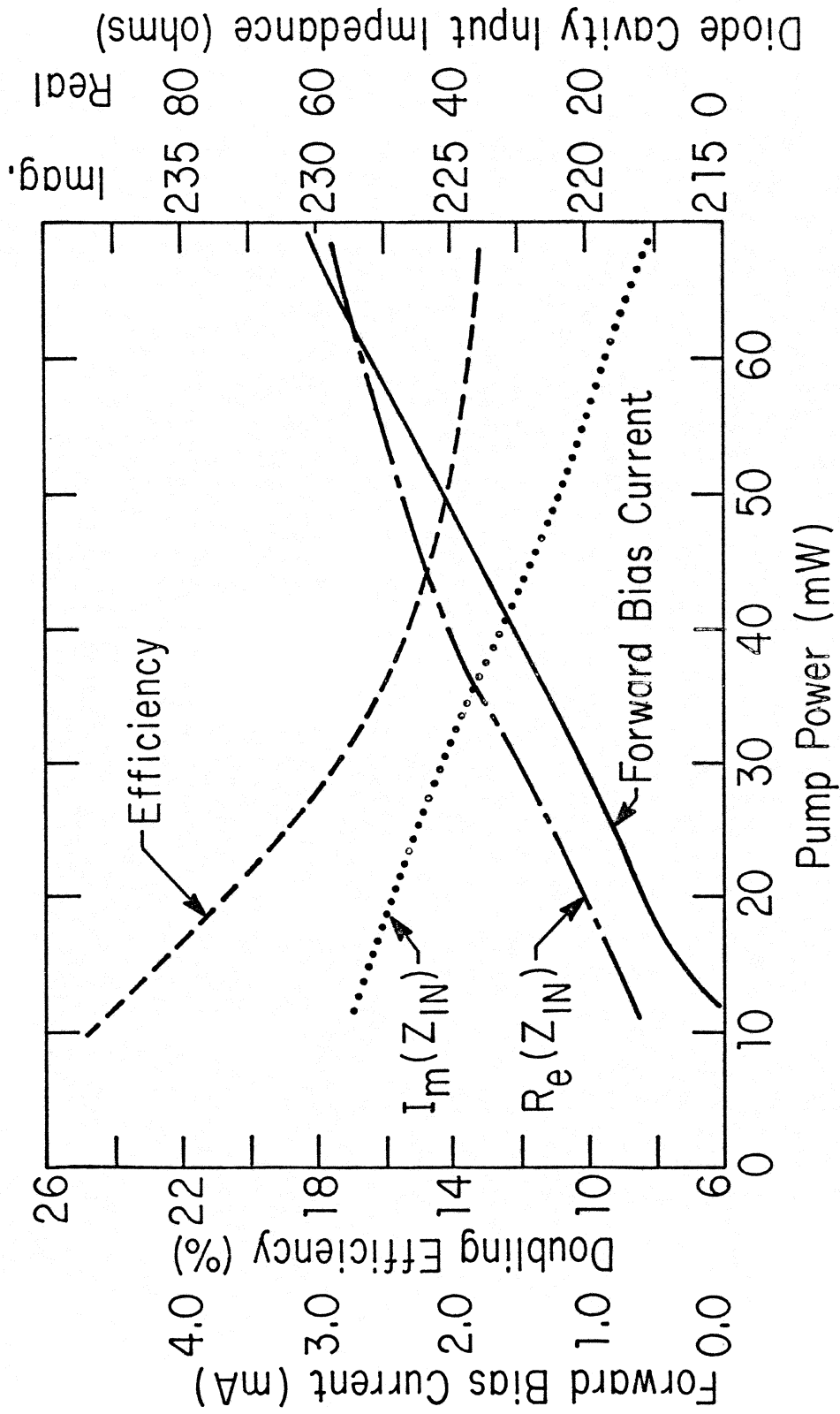

Figure 2: Predicted average forward current, maximum second harmonic conversion efficiency and diode impedance at the pump frequency, as a function of pump power at 70 GHz. These curves are for the 5 μm diode mounted in the reduced height waveguide cavity, as described in the text.

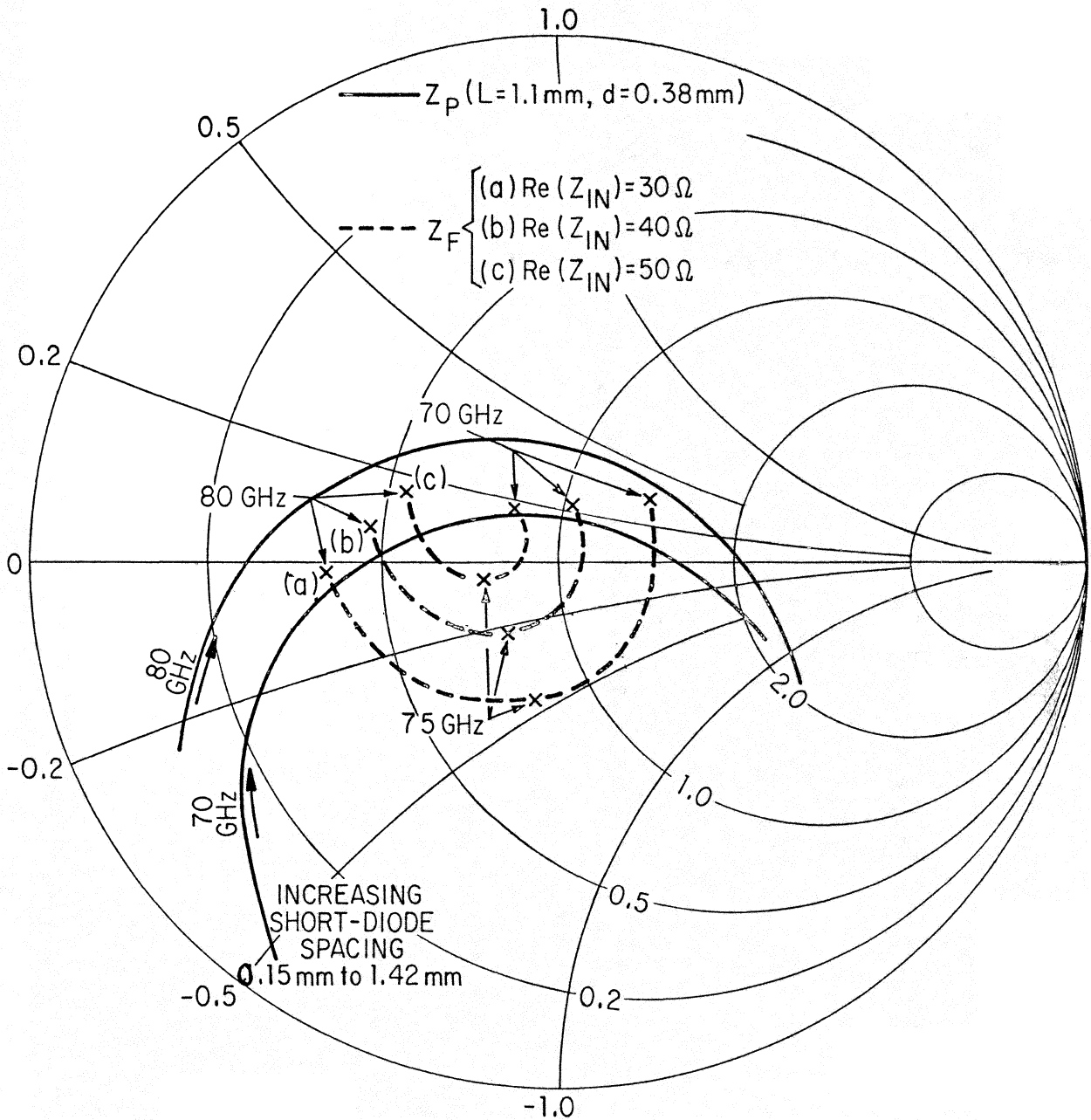

Figure 3: Predicted input impedance (Z_F) of the pump circuit for the reduced height mount with the $5 \mu\text{m}$ diode, as a function of pump frequency and power. Also shown is the dependence of the input impedance (Z_P) of the transition to the pump waveguide on frequency and backshort position.

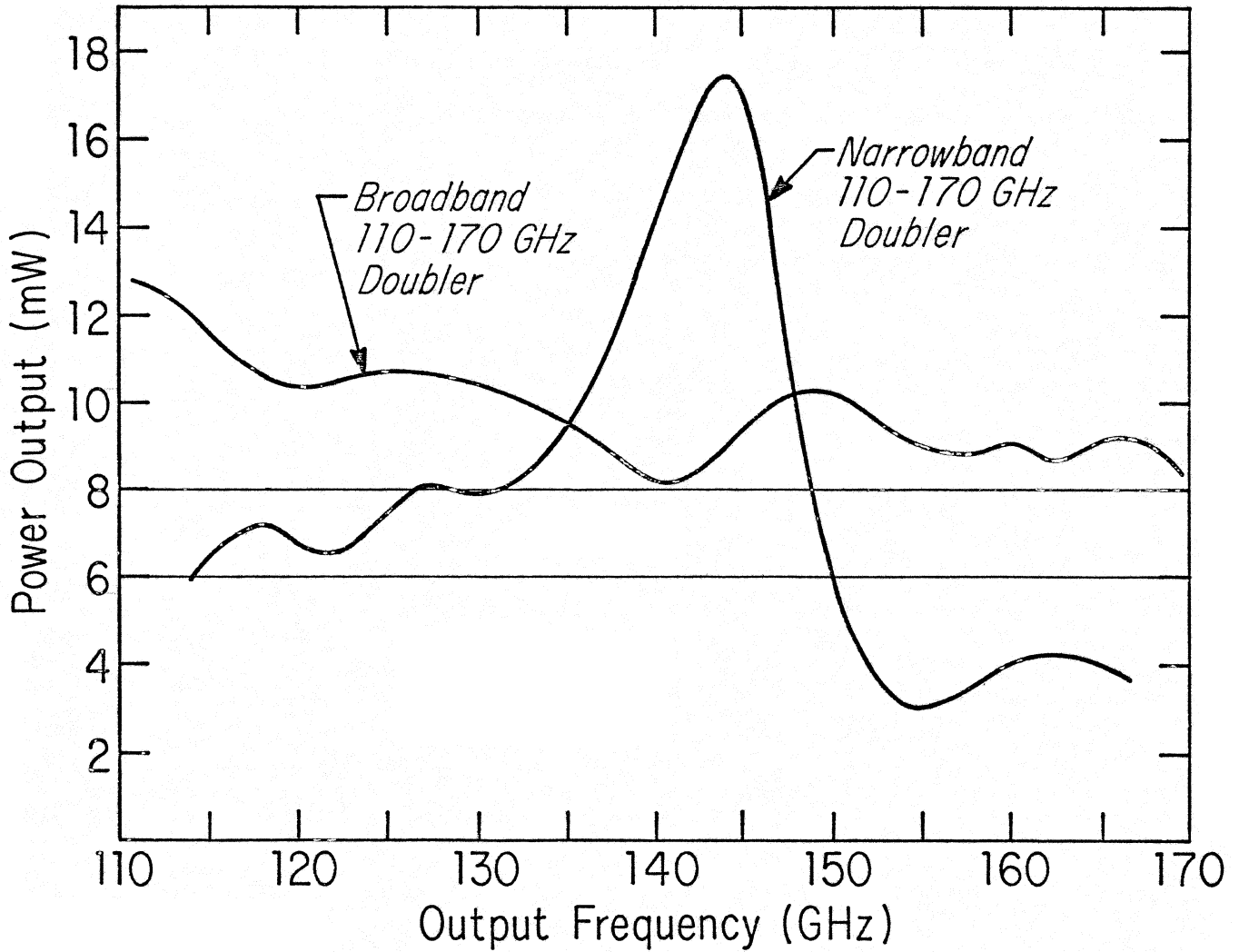

Figure 4: Performance of the 100 - 170 GHz output frequency multipliers. Pump power held constant at 80 mW.

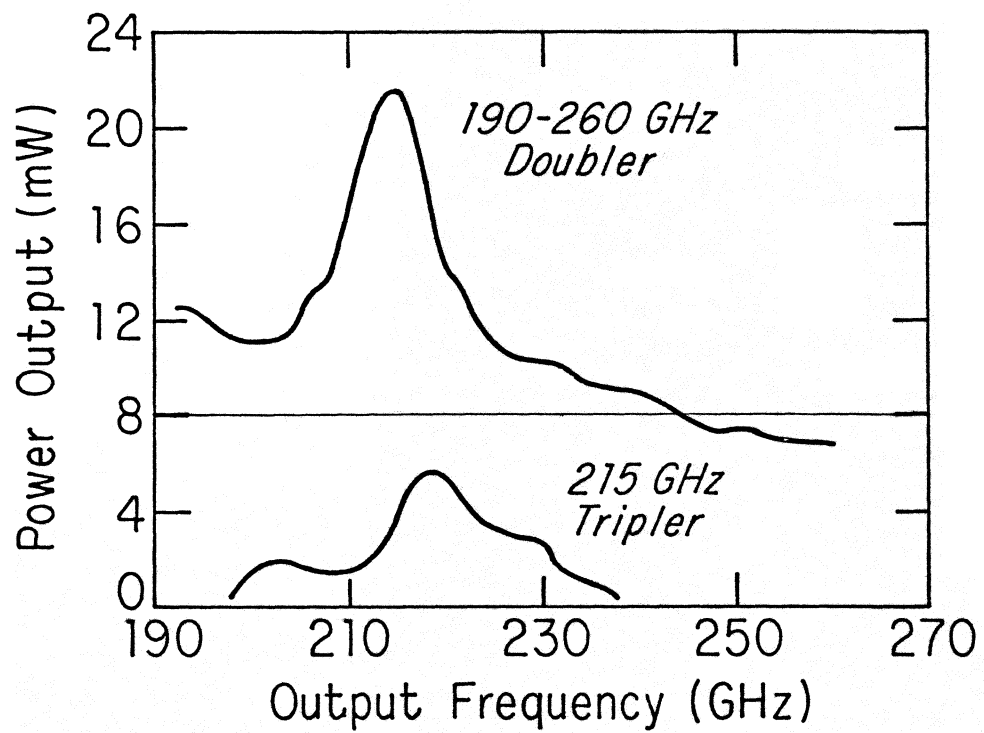

Figure 5: Performance of the 170 - 260 GHz output frequency multipliers. Pump power held constant at 80 mW.