

NATIONAL RADIO ASTRONOMY OBSERVATORY
CHARLOTTESVILLE, VIRGINIA

ELECTRONICS DIVISION INTERNAL REPORT No. 208

LOSS OF FERRITE BEADS AT MICROWAVE FREQUENCIES

M. W. SINCLAIR

SEPTEMBER 1980

NUMBER OF COPIES: 150

LOSS OF FERRITE BEADS AT MICROWAVE FREQUENCIES

M. W. Sinclair*

1. Introduction

Ferrite beads are useful for suppression of high frequency oscillations in microwave FET amplifiers such as the L-band amplifier described by Williams, Lum, and Weinreb [1]. This report describes measurements of two ferrite beads, Types T10-6 and T12-6, manufactured by Micrometals, Inc., 1190 North Hawk Circle, Anaheim, California, 92807. The beads are not characterized by the manufacturer at microwave frequencies or at cryogenic temperatures so measurements were performed from 4 to 18 GHz and at temperatures of 300K and 20K.

The measurements consisted of transmission loss measurements over a wide frequency range of a 50Ω coaxial holder with the bead mounted concentrically on the centre conductor, and impedance measurements of the bead terminated alternately by a short and open circuit. The transmission loss measurements were made to gain some idea of the over-all loss-frequency characteristics of the bead, whereas the impedance measurements should give some idea of the equivalent circuit of the bead mounted in the coaxial structure.

2. Bead Dimensions and Test Holders

The physical dimensions of the beads are as follows:

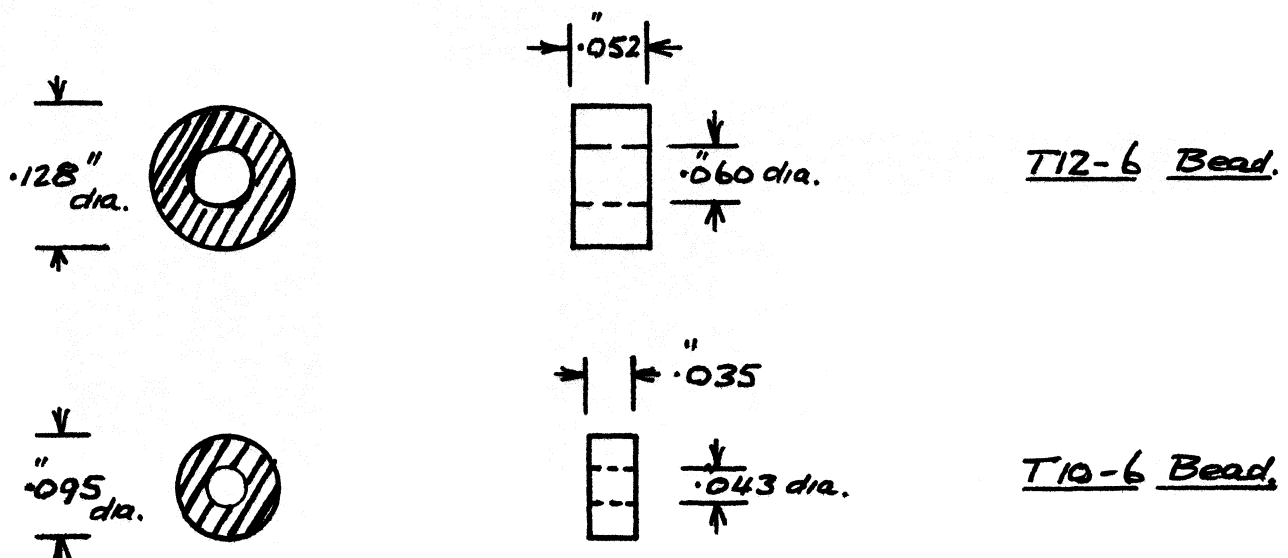

* On leave of absence from CSIRO, Division of Radiophysics, Epping, Australia

Accordingly, two test holders were made to mount the beads in a 50 Ω coaxial line thus:

(a) T12-6 bead

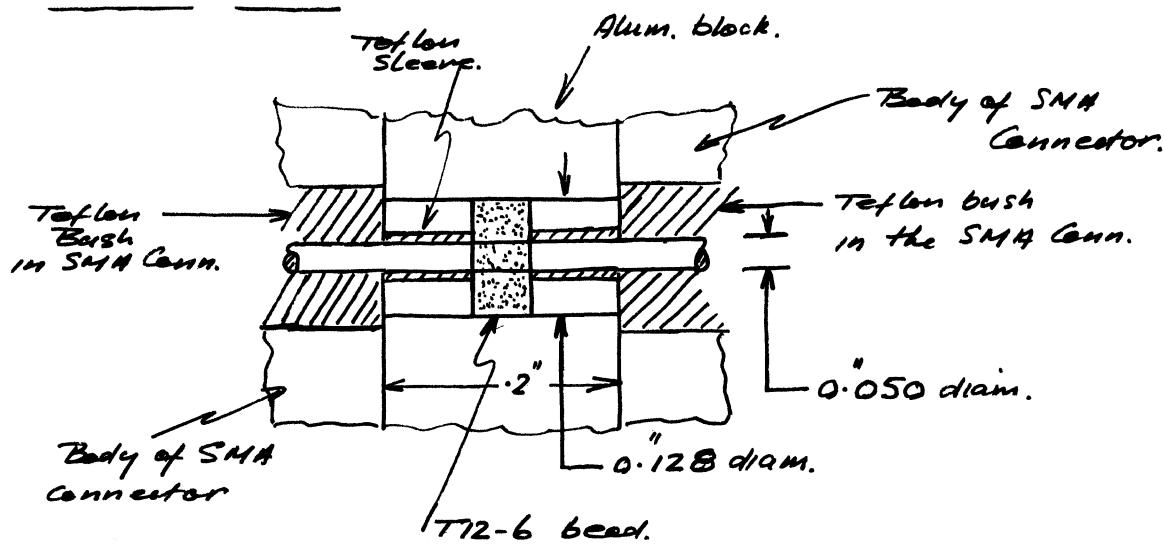

The coaxial line dimensions were determined by the outside diameter of the T12-6 bead (0.128) and the standard SMA inner pin diameter (0.050). This yields a characteristic impedance $Z_{line} = 56 \Omega$ for air dielectric, but by partially sleeving the inner with Teflon tubing, the impedance is made nearer to 50 Ω.

(b) T10-6 bead

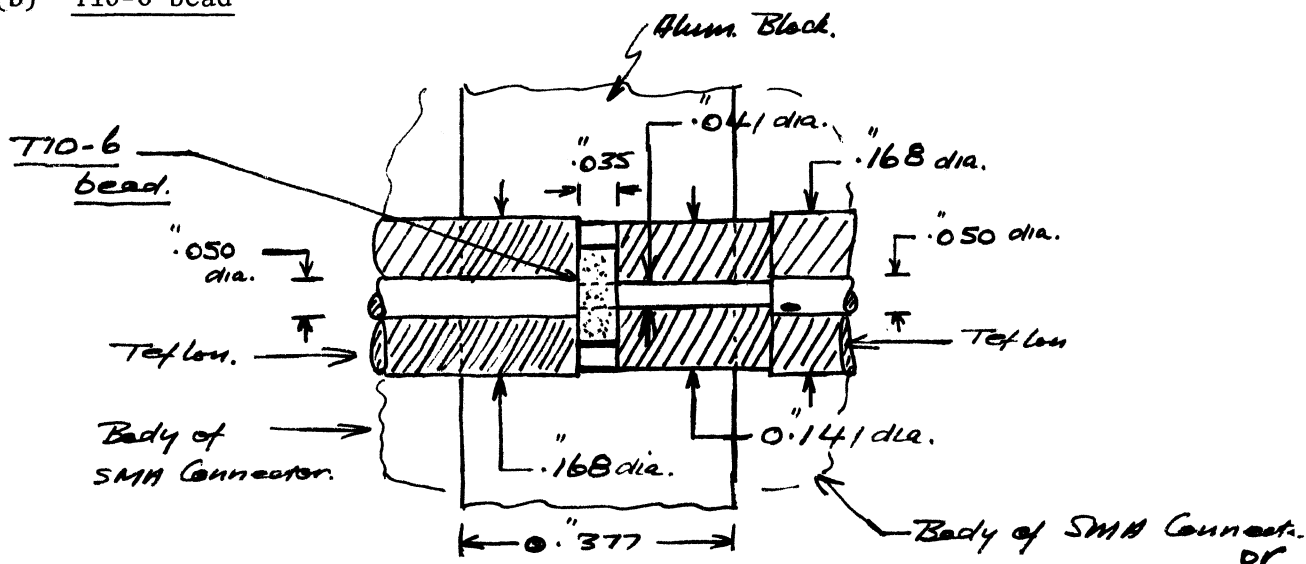

In this holder a larger outer diameter was used with full Teflon dielectric. This enabled the small bead to be fitted to the coaxial inner line diameter of 0.041.

3. Results:

(i) Transmission Loss Measurements

The transmission loss measurements were made using a test arrangement as shown:

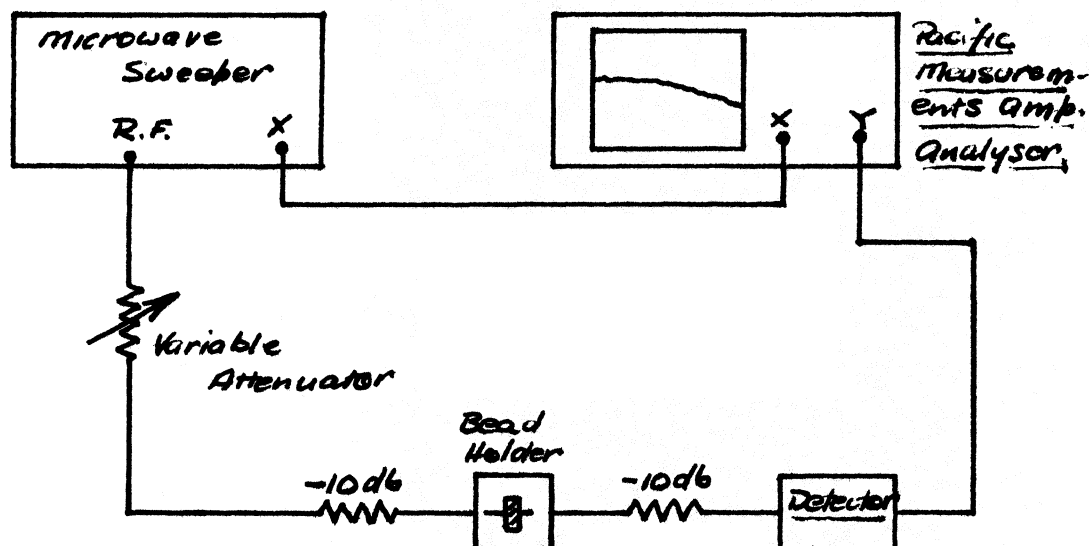

Where possible the range of 4 to 18 GHz was covered in three steps: 4 → 8 GHz, 8 → 12.4 GHz and 12.4 → 18 GHz. The frequency vs. Loss characteristics of the bead holders with and without the beads, relative to an SMA female to female adaptor, were measured for each frequency band. The differences in attenuation with and without the beads were then calculated as a function of frequency and the results are shown in Figure 1.

Figs 1(a) and 1(b) are the measured data of relative attenuation plots for the T12-6 bead and T10-6 bead respectively. The T12-6 bead and holder were then cooled to 20°K and the transmission loss over the frequency range 12.5 to 18 GHz compared to that obtained at room temperature. These results are shown in Fig. 1(c). For completeness, a transmission loss plot of the holder without the bead at both 20°K and room temperature is shown in Fig. 1(d).

(ii) Impedance Measurements

Two sets of impedance measurements were made:

- (a) The bead was terminated by a short circuit, and the resultant bead - short circuit reflection coefficient (S_{11}) measured over a frequency range of 4 to 12 GHz using an H.P. Network Analyser.

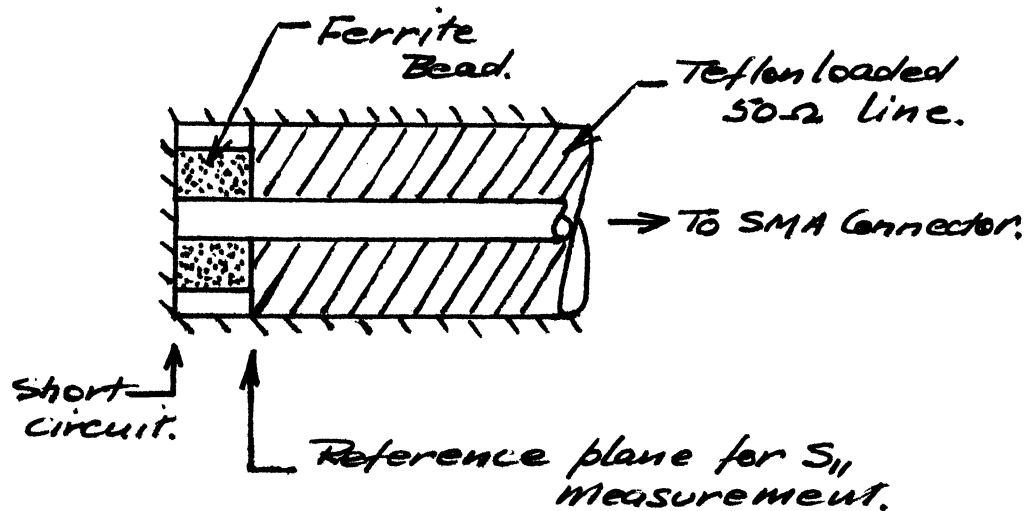

The results of this test are shown in Figs. 2, 3 and 4.

- (b) The bead holder with the bead removed was connected to a sliding short circuit which was adjusted until an open circuit was effected at the plane of the bead. The bead was then inserted and the change in reactance noted. This test was done for both beads at one frequency only: 4.75 GHz.

The results are plotted on Figs. 2 and 3.

4. Discussion of Results

(i) Transmission Loss Measurements

T10-6 Bead

These measurements (Fig. 1) showed only a small increase in relative attenuation (~ 1 db) over the frequency range measured (8 \rightarrow 18 GHz). Accurate measurements down to 4 GHz were not made but can be inferred by the over-all slope of the attenuation characteristic, indicating an approximate 1.5 db increase in the attenuation between 4 GHz and 18 GHz.

No cooled measurements were made on this bead.

T12-6 Bead

These measurements (Fig. 1) indicated a considerable increase in attenuation over the frequency range 4 → 18 GHz (~ 6.5 db). This bead is substantially larger than the T10-6 bead and the increased loss presumably reflects the larger volume of ferrite material in the bead. The bead also effectively filled all of the available cross-sectional area of the coaxial line whereas the T10-6 bead did not.

The cooled measurements on this bead would seem to indicate no major variation in transmission loss when cooled to 20°K, at least over the frequency range 12.5 → 18 GHz. The measurements ought to be repeated, particularly at lower frequencies, to determine if the cross-over point at ~ 13.5 GHz is a genuine one and not due to a problem in the test holder. The measurement shown in Fig. 1(d) would seem to indicate that the effect is genuine.

(ii) Impedance Measurements

Using the value of series impedance found by terminating the bead in a short circuit, and the value of shunt capacitive susceptance implied with the bead at an open circuit plane, an attempt has been made to characterise an equivalent circuit, (at 4.75 GHz at least) for each bead at room temperature.

If we assume a T-equivalent circuit of the form:

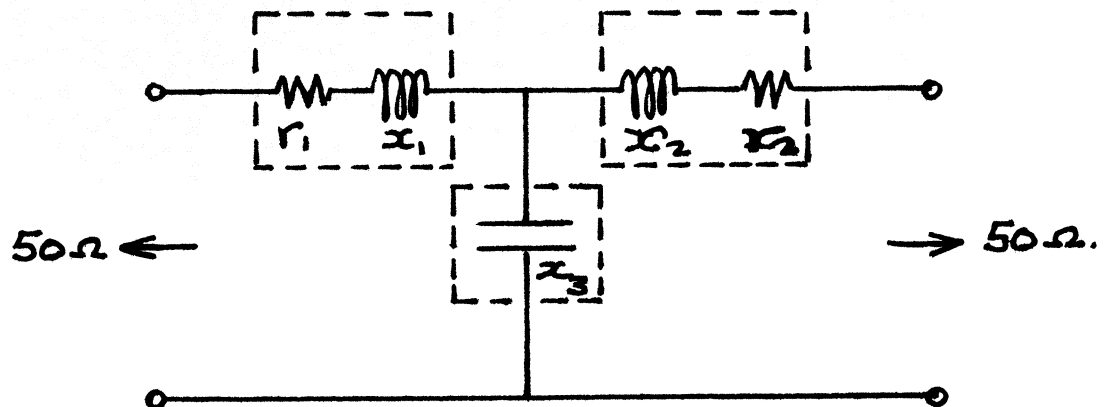

Then the element values at 4.75 GHz are:

<u>T12-6 Bead</u>	<u>T10-6 Bead</u>
$r_1 = r_2 = 7\Omega$	$r_1 = r_2 = 5.3\Omega$
$L_1 = L_2 = 0.3 \text{ nH}$	$L_1 = L_2 = 0.23 \text{ nH}$
$C_3 = 0.07 \text{ pf}$	$C_3 = 0.1 \text{ pf}$

5. Conclusions

The transmission loss of two types of Micrometals ferrite beads (T12-6 and T10-6) has been measured over a wide range of microwave frequencies. The loss is found to increase with frequency, with the larger bead (T12-6) having a greater rate of increase of loss than the smaller bead.

The change in loss of one bead (T12-6) at cryogenic temperatures was examined over part of the frequency range (12 to 18 GHz) with no major variation in attenuation being seen. However, these measurements should be repeated at the lower end of the frequency range (4 to 12 GHz) to cover the possibility of a change in loss at these frequencies.

An approximate equivalent circuit has been derived at 4.75 GHz for both beads from impedance data obtained with the beads terminated by short and open circuits. Equivalent circuits at other frequencies can be derived by reference to this impedance data.

REFERENCES

- [1] D. R. Williams, S. Weinreb, and W. Lum, "L-Band Cryogenically-Cooled GASFET Amplifier", to be published, Microwave Journal, October, 1980.

Fig 1

Micrometals

Ferrite Bead Transmission Attenuation
VS Frequency (in 50- Ω Test Holder)

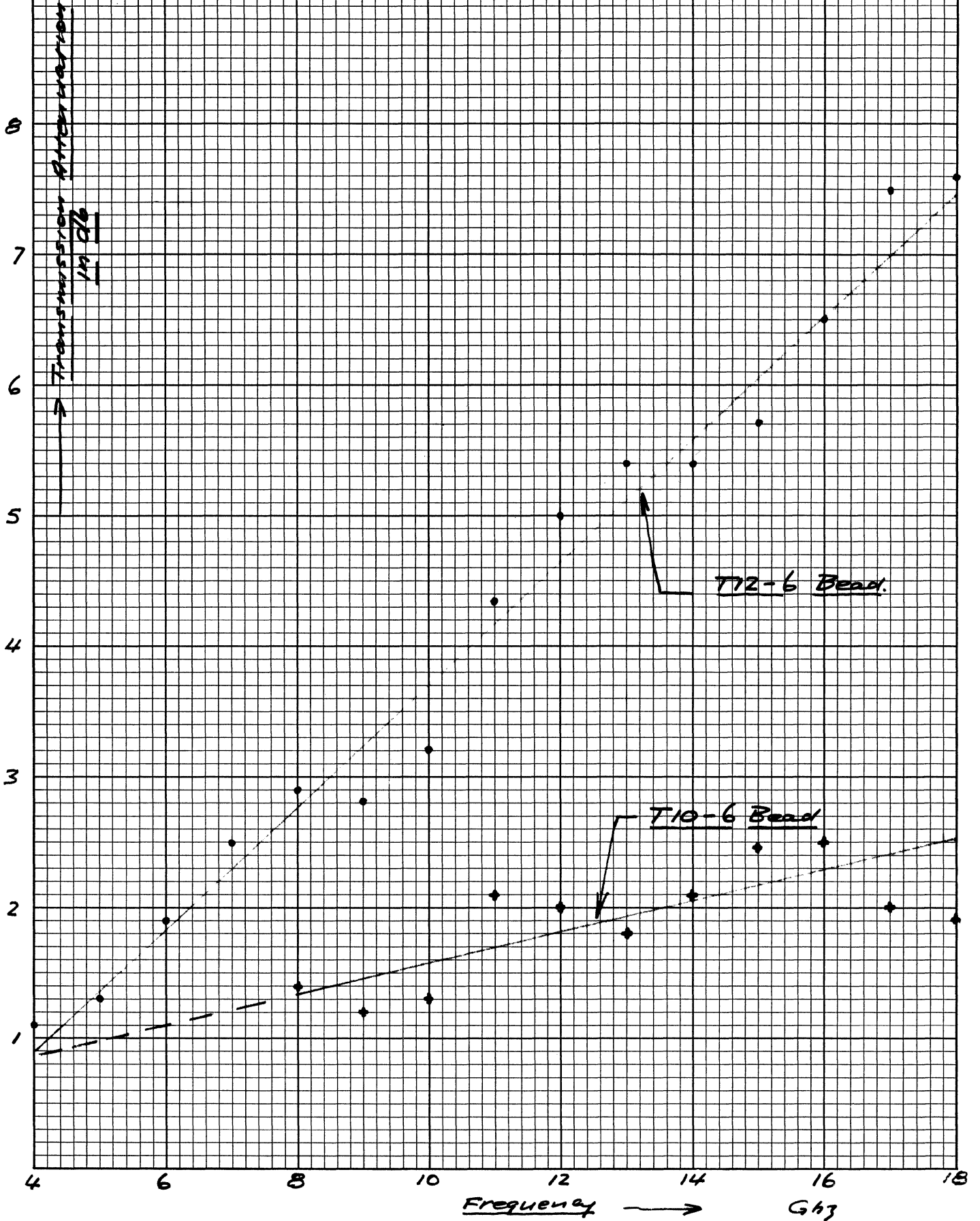

Transmission Loss Measurements: T12-6 Bead. (Large).
4 → 18 GHz Results - Room Temp.

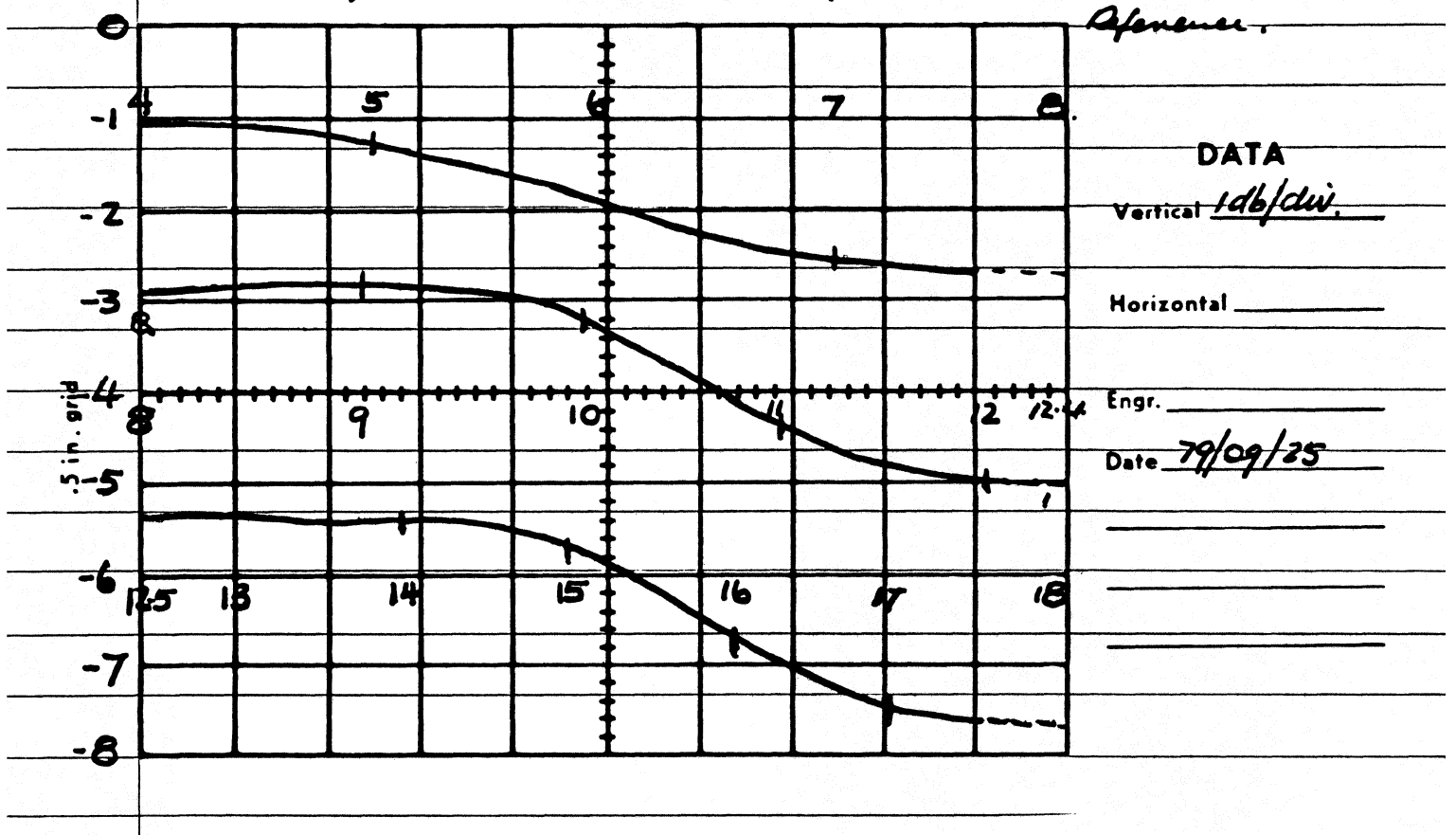
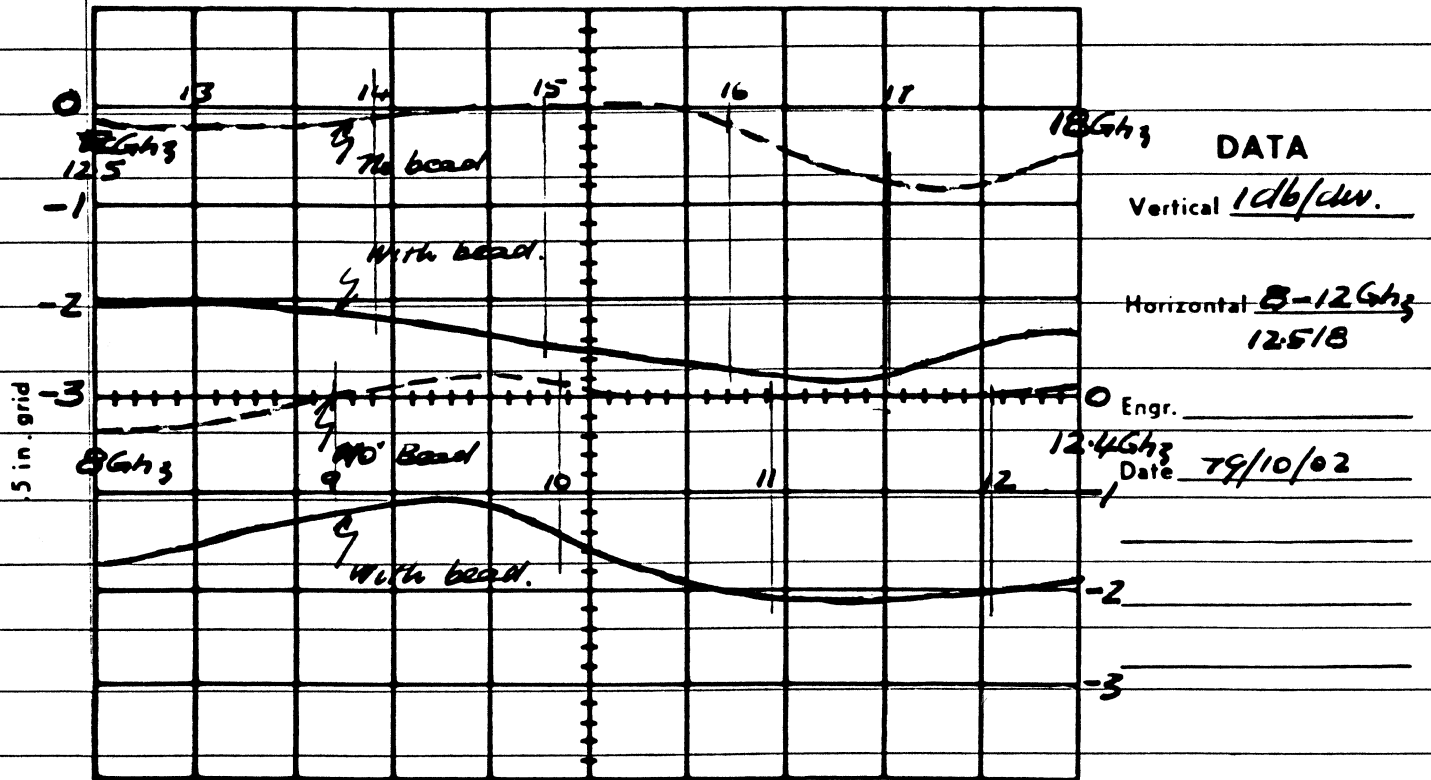

Fig 1(a).

Transmission Loss Measurements, T10-6 Bead (Small)

79/10/02.

X & Ku-Band Loss Measurements.



Transmission loss for holder with bead and without bead.

Fig 1.(b)

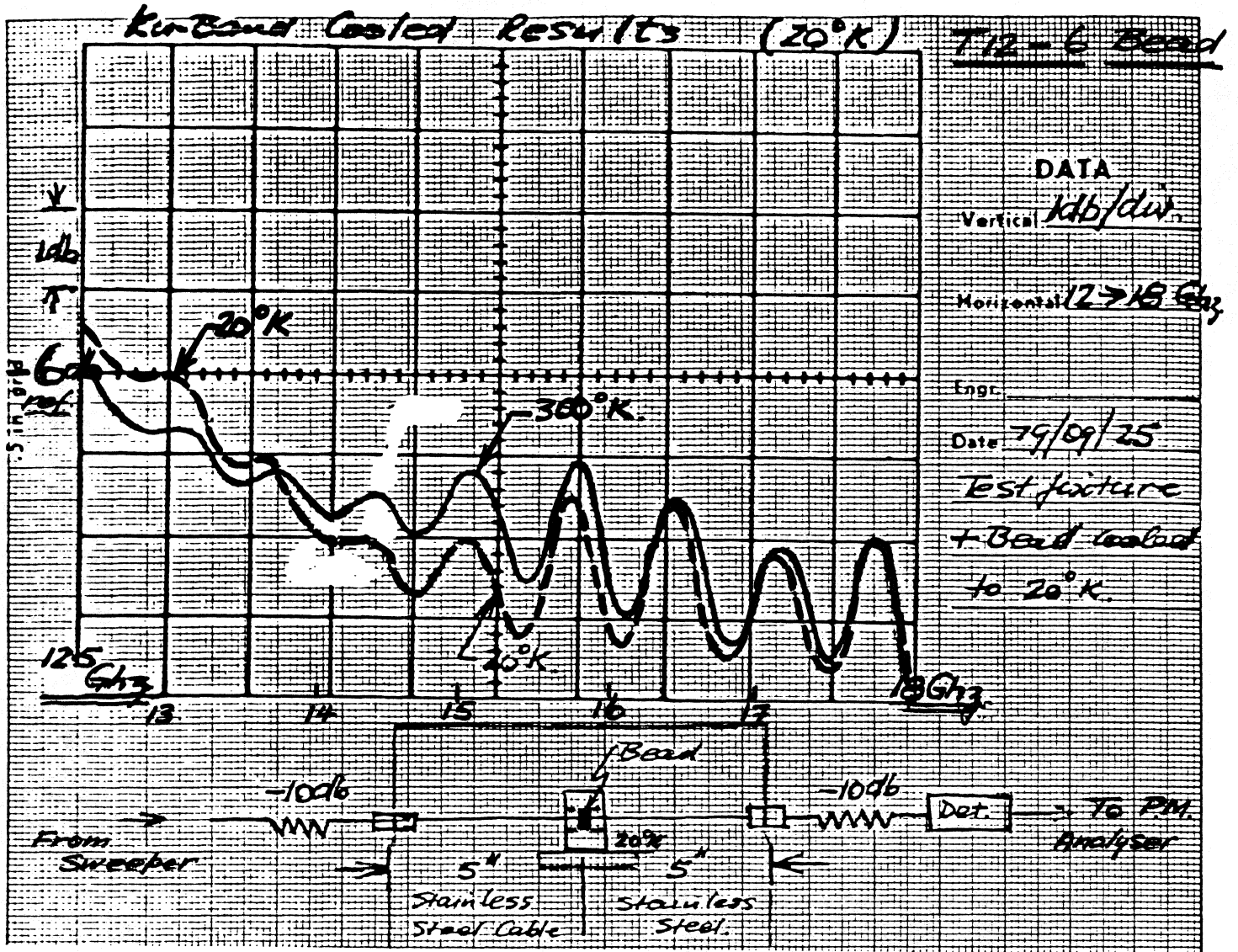
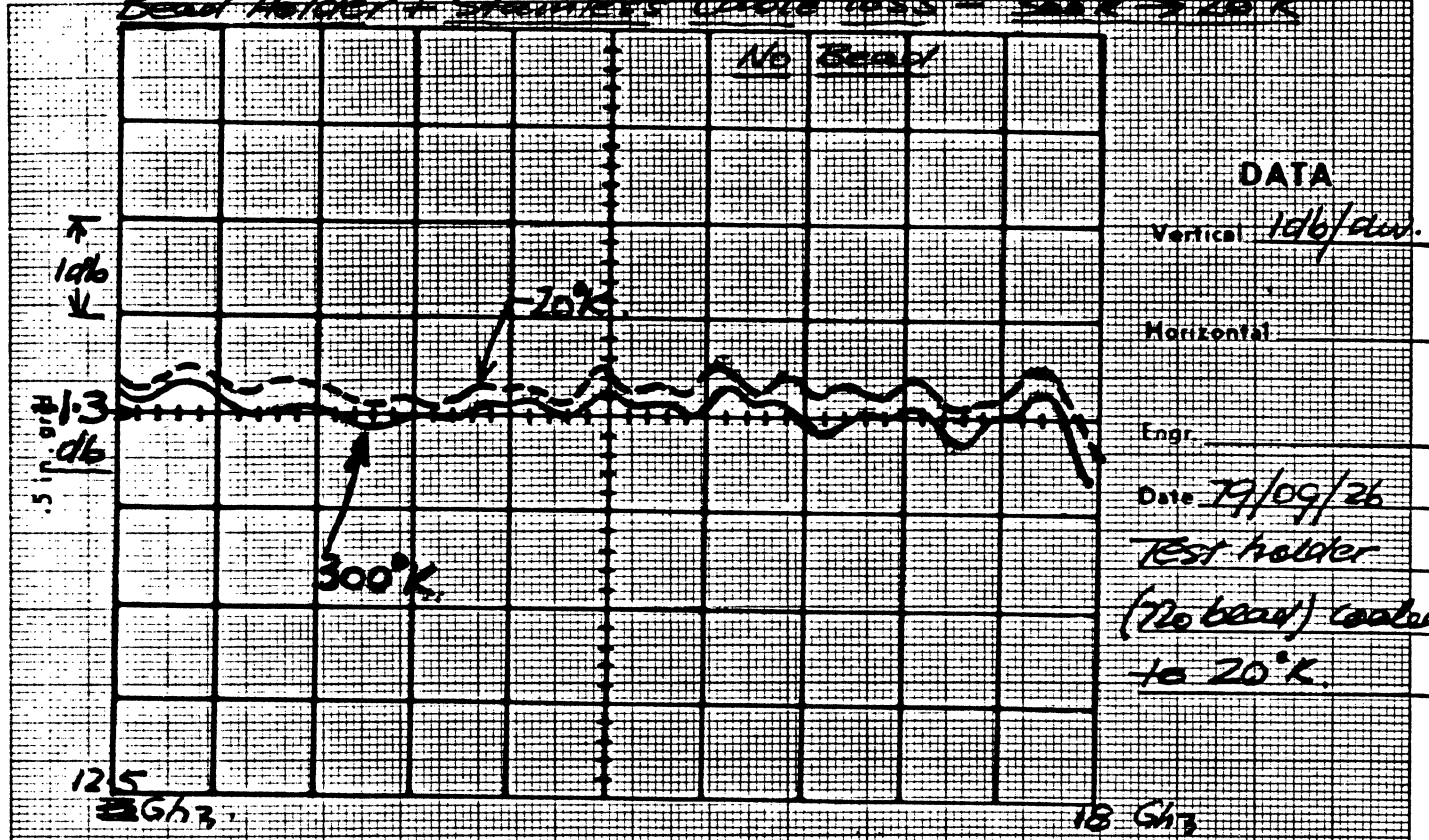

Fig. 1(c).

Bead Holder + Stainless Cable loss - 300°K → 20°K



DATA
 Vertical: 1dB/div.
 Horizontal: _____
 Engr. _____
 Date: 19/09/26
 Test holder
 (No bead) cooled
 to 20°K.

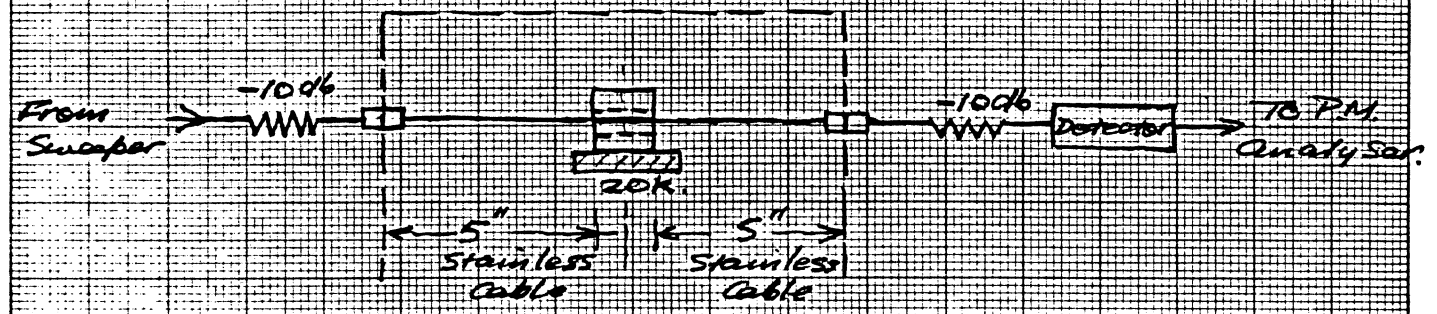

Fig 1(d)

TITLE Micrometals T10-6 Bead.

FIG. 2

DATE 7/10/04

Short Circuit behind bead.

Frequency Range: 4 → 6.5 GHz.

Reference IMPEDANCE COORDINATES—50-OHM CHARACTERISTIC IMPEDANCE
in front of bead.

$Z_0 = 50 \Omega$

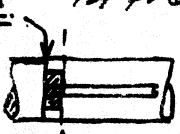

Ref. Plane.

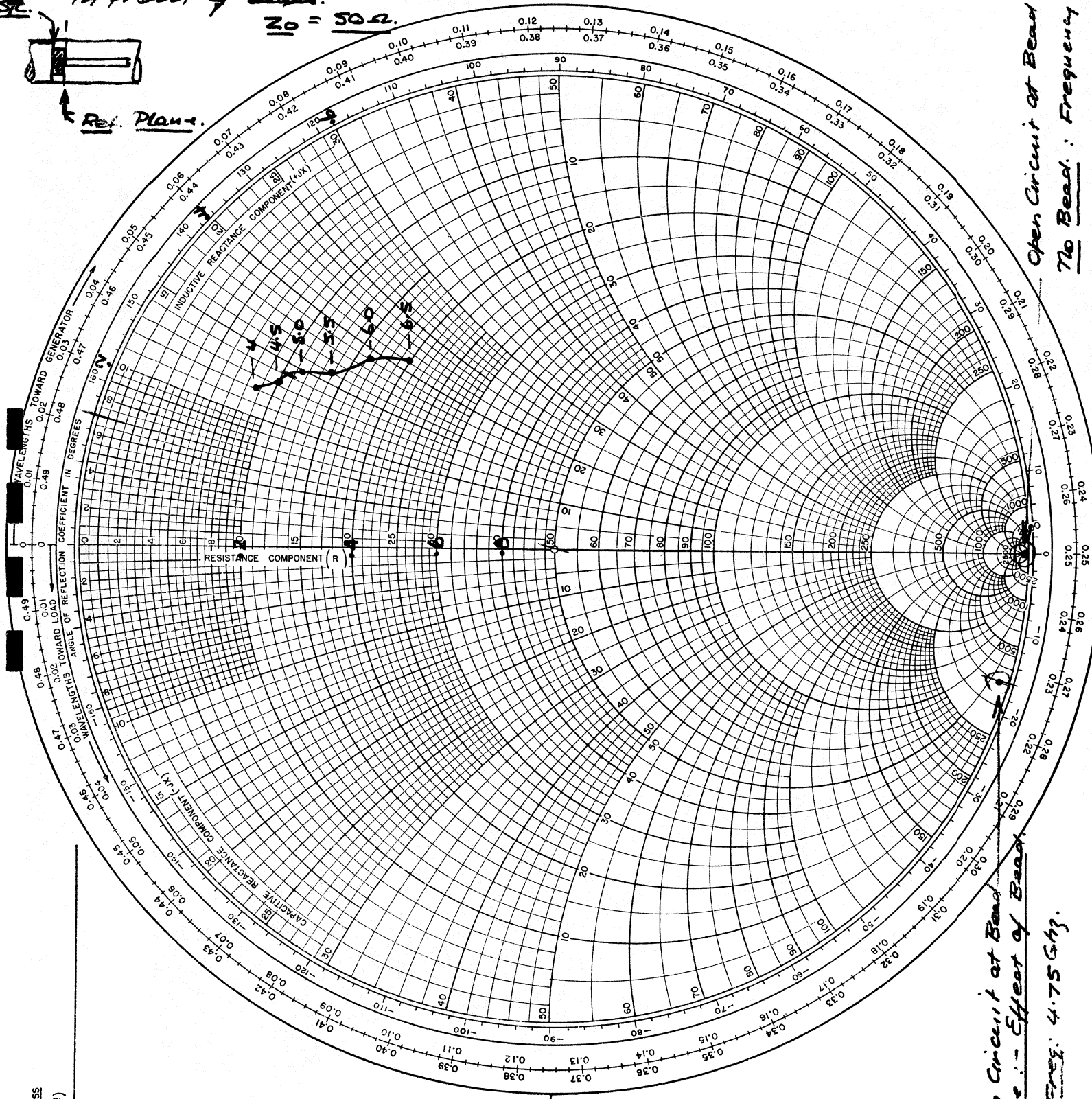

Open Circuit at Bead Plane.
710 Bead: Frequency - 4.75 GHz

Open Circuit at Bead Plane: - Effect of Bead.
Freq. 4.75 GHz.

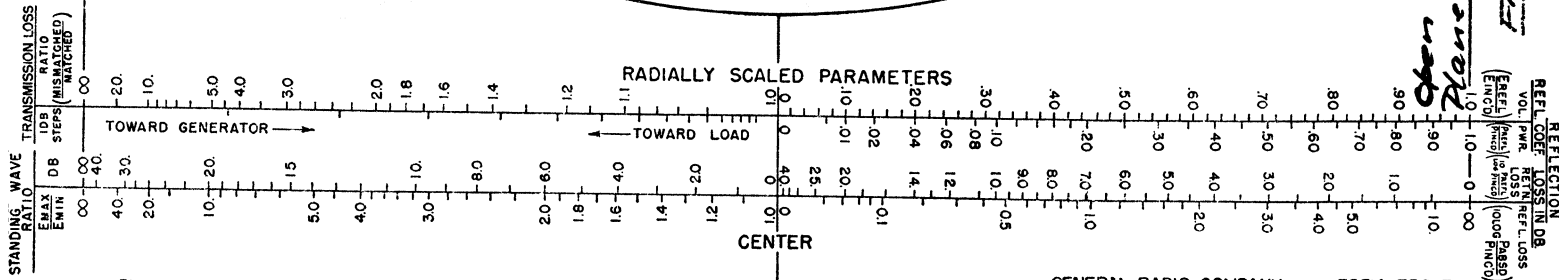

TITLE Micrometals Bead: 712-6

Fig. 3

DATE 79/10/64

Short circuit behind bead

IMPEDANCE COORDINATES—50-OHM CHARACTERISTIC IMPEDANCE
Reference plane in front of Bead.

Freq. Range: 4 → 7 GHz

$Z_0 = 50\Omega$

Open Circuit at Bead Plane
No Bead: Frequency: 4.75 GHz

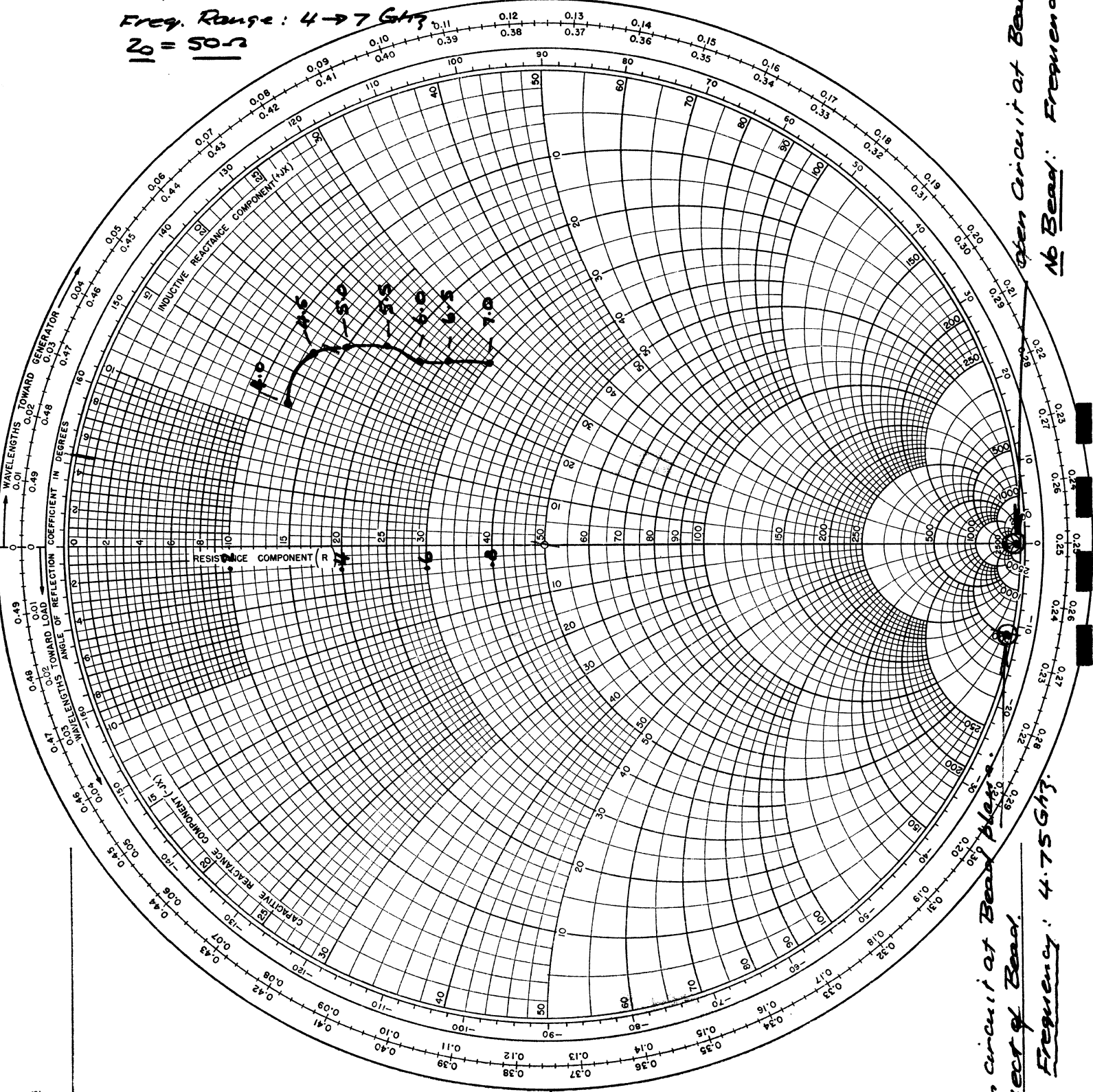

Open circuit at Bead plane.
Effect of Bead.
Frequency: 4.75 GHz.

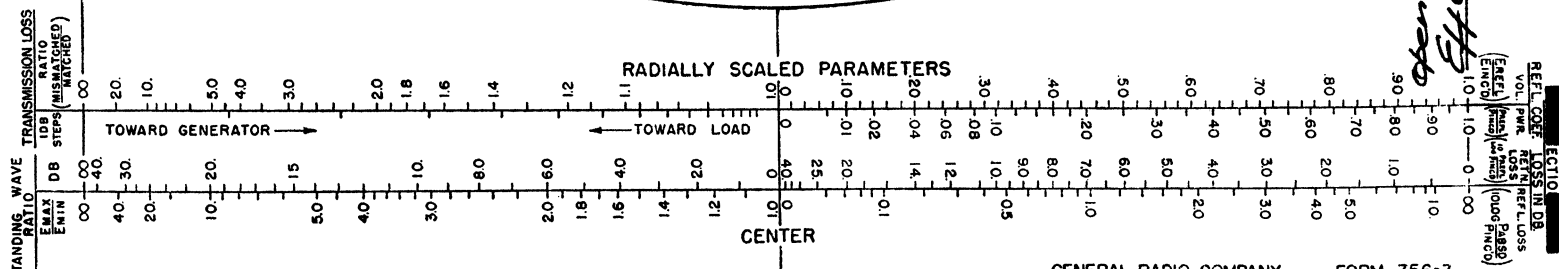

TITLE T10-6 & T12-6
B → 12 Ghz B → 12 Ghz

Fig. 4

DATE 79/10/05

IMPEDANCE COORDINATES—50-OHM CHARACTERISTIC IMPEDANCE

Short Circuit behind Bead.

Reference plane in front of Bead.

Z₀ = 50Ω

