

NATIONAL RADIO ASTRONOMY OBSERVATORY
GREEN BANK, WEST VIRGINIA

ELECTRONICS DIVISION INTERNAL REPORT No. 194

A 2 TO 18 GHz SIGNAL SOURCE
FOR THE
GREEN BANK ANTENNA RANGE

J. R. FISHER AND W. D. KUHLEN

OCTOBER 1978

NUMBER OF COPIES: 150

A 2 to 18 GHz SIGNAL SOURCE
FOR THE GREEN BANK ANTENNA RANGE

J. R. Fisher and W. D. Kuhlken

Introduction

The signal source described in this report was built to improve the accuracy and convenience of the Green Bank antenna range. In the past a remotely controlled HP 8690 sweep generator has been used as the antenna range source, but its residual FM of a few tens of kHz added noise to antenna phase measurements and often made it difficult to lock the receiver LO to the transmitted signal. To cover the 2 to 18 GHz range four plug-ins were required which could be a particular nuisance if an antenna under test overlapped two plug-in frequency ranges. Although the new source does not cover the full 0.1 to 40 GHz capability of the antenna range, it, along with the 1 to 2 GHz LO multiplier, provides a synthesizer derived signal for the most heavily used portion of the spectrum.

The Antenna Range

The Green Bank antenna range has one movable and one fixed tower which hold the transmitting antenna and the antenna under test approximately 8.4 meters above level ground. The distance between the two antennas can be varied from about 4 to 16 meters. The antenna under test is mounted on a Scientific Atlanta vertical axis turntable. The received signal is heterodyned at the antenna and sent to the receiver hut at the base of the tower. The receiver is a Scientific Atlanta Model 1754 phase and amplitude system which can operate from 0.1 to 40 GHz.

The minimum detectable signal below 18 GHz at the antenna under test is -105 dBm, and the phase reference signal in an auxiliary receiving antenna must be at least -60 dBm. With a 15 dB transmitting antenna gain at 18 GHz the

unknown antenna pattern can be measured to about 38 dB below an isotropic reference pattern under ideal conditions with 1 mW of transmitter power. Under the same conditions an auxiliary antenna with 7 dB of gain is required to meet the -60 dBm phase reference signal requirement. The new signal source provides about 2 mW of power at 18 GHz and over 20 mW below 8 MHz.

System Layout

The 2-18 GHz signal source is based on a voltage controlled YIG tuned multiplier which is driven by a signal anywhere in the 1 to 2 GHz band. The multiplier is packaged with its driver amplifier, D/A converters for frequency control, level monitoring circuitry, and associated power supplies in a single chassis in the transmitter tower. The 1 to 2 GHz driver signal is generated by the spare universal local oscillator (ULO) system in the lab building and is sent to the multiplier chassis via semirigid and RG 214 coaxial cables.

Both the ULO and multiplier frequencies are digitally controlled from the receiver hut via multiconductor cables. The remote control panel also contains multiplier drive and output power monitor meters.

The Multiplier Chassis

Figure 1 is the multiplier chassis schematic, and the details of the D/A converter circuitry are shown in Figure 3. Some of the mechanical specifications and power supply requirements of the YIG tuned multiplier are shown in Figure 2.

The YIG device requires up to one watt of 1 to 2 GHz drive power. Since there is about 20 dB of loss in the coax between the lab and the antenna tower a 30 dB gain amplifier is used to drive the multiplier. The drive level monitor amplifier is designed for about 1 V output (meter full scale on X1 setting) for

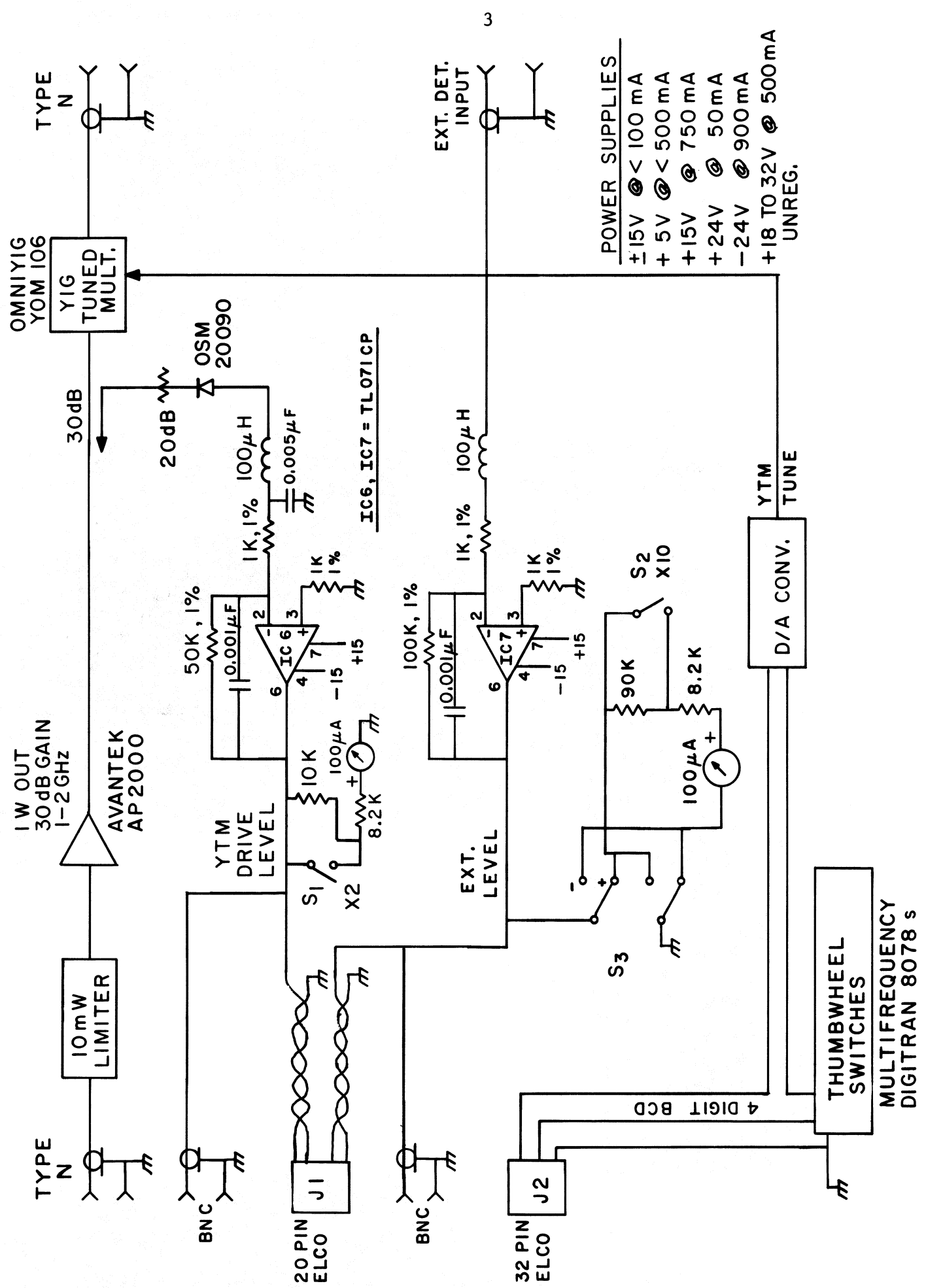
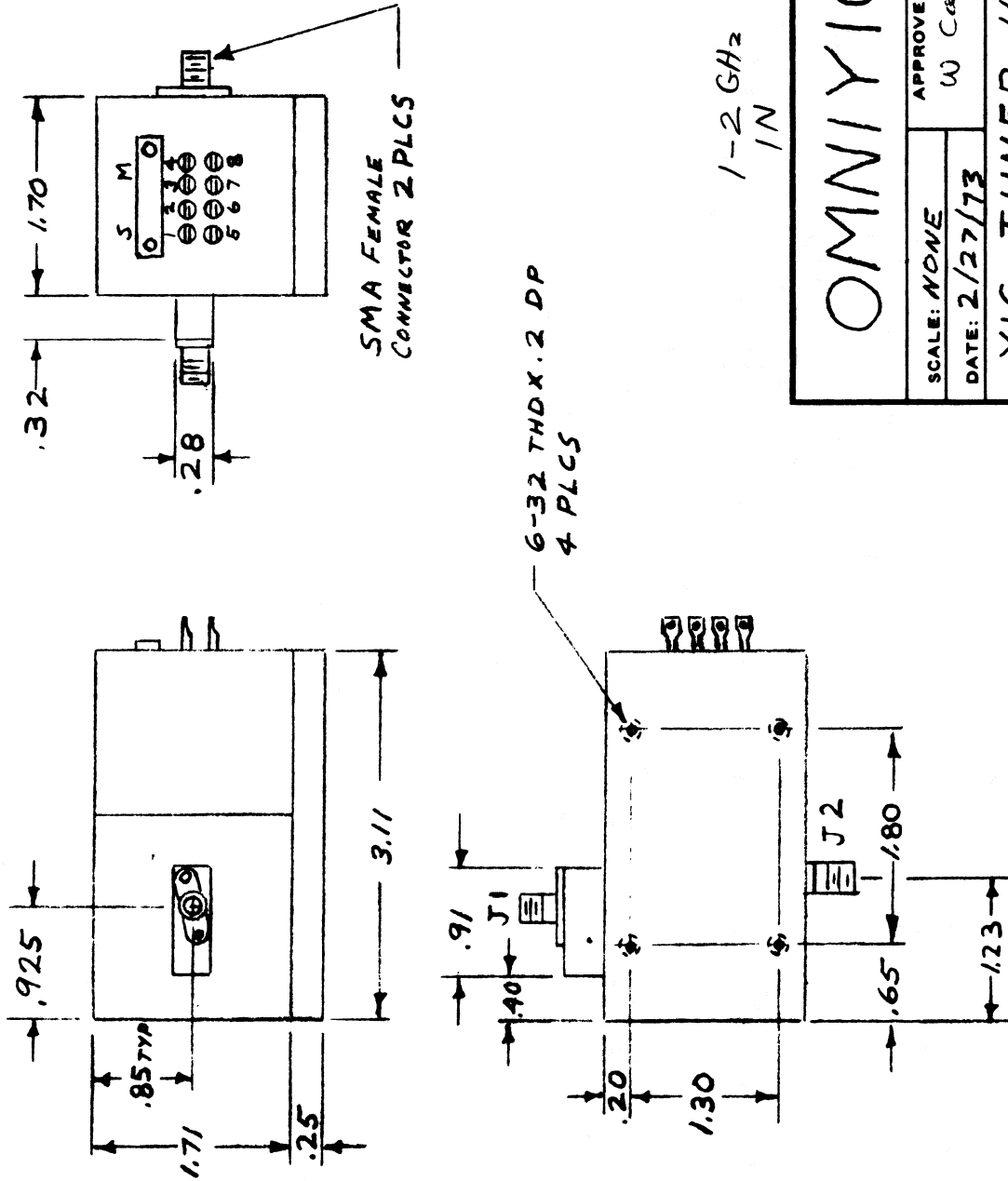

Figure 1. 2 to 18 GHz Multiplier Chassis Circuit (transmitter tower).



CONNECTIONS	
CONN.	FUNCTION
1	0-10 V Driver Control
2	0 V Ground
3	-24 VDC at 900 MA
4	+24 VDC at 50 MA
*5	20-30V Heater sup.
*6	Heater return 500-80 MA
7	N/C
8	N/C
J1	RF FUNDAMENTAL INPUT
J2	RF HARMONICS OUTPUT
S	START CURRENT adjust (@ 0V control)
M	Max adjust (AI: @ 10V control)

* 24 V supply.

[YOM-106]

2-18 GHz =
OUT.

1-2 GHz
IN

OMNIYIG INC.

SCALE: NONE
DATE: 2/27/73

APPROVED BY G. J. King 11/2/76
W. Caporaso 2/27/73

DRAWN BY

YIG TUNED HARMONIC MULTIPLIER
WITH DRIVER

Tolerance: ±.03
SIZE A

SN-101

DRAWING NUMBER
82,303-01

Figure 2.

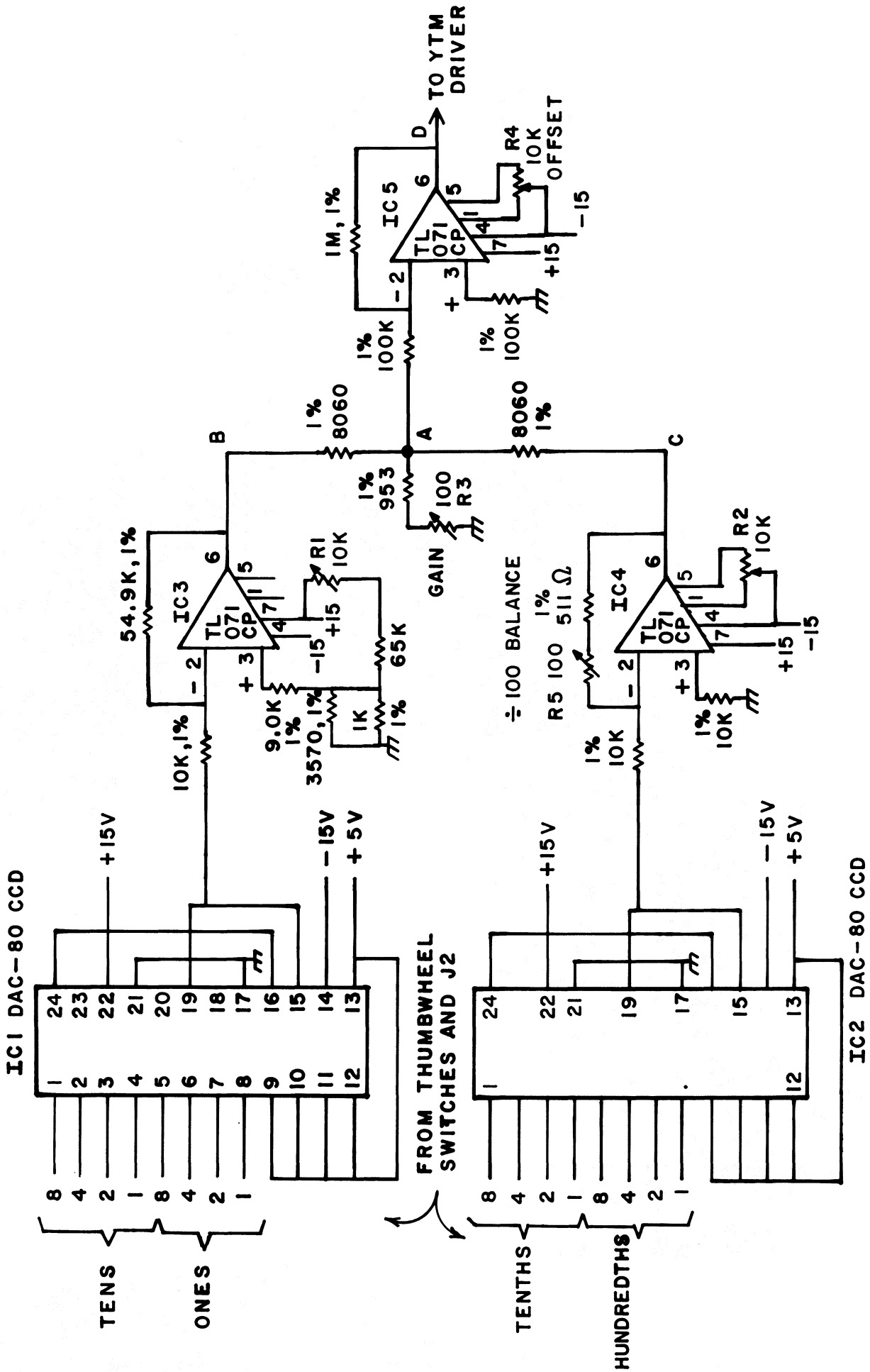

Figure 3. D/A Converter Circuits for the YIG Tuned Multiplier Frequency Control (transmitter tower).

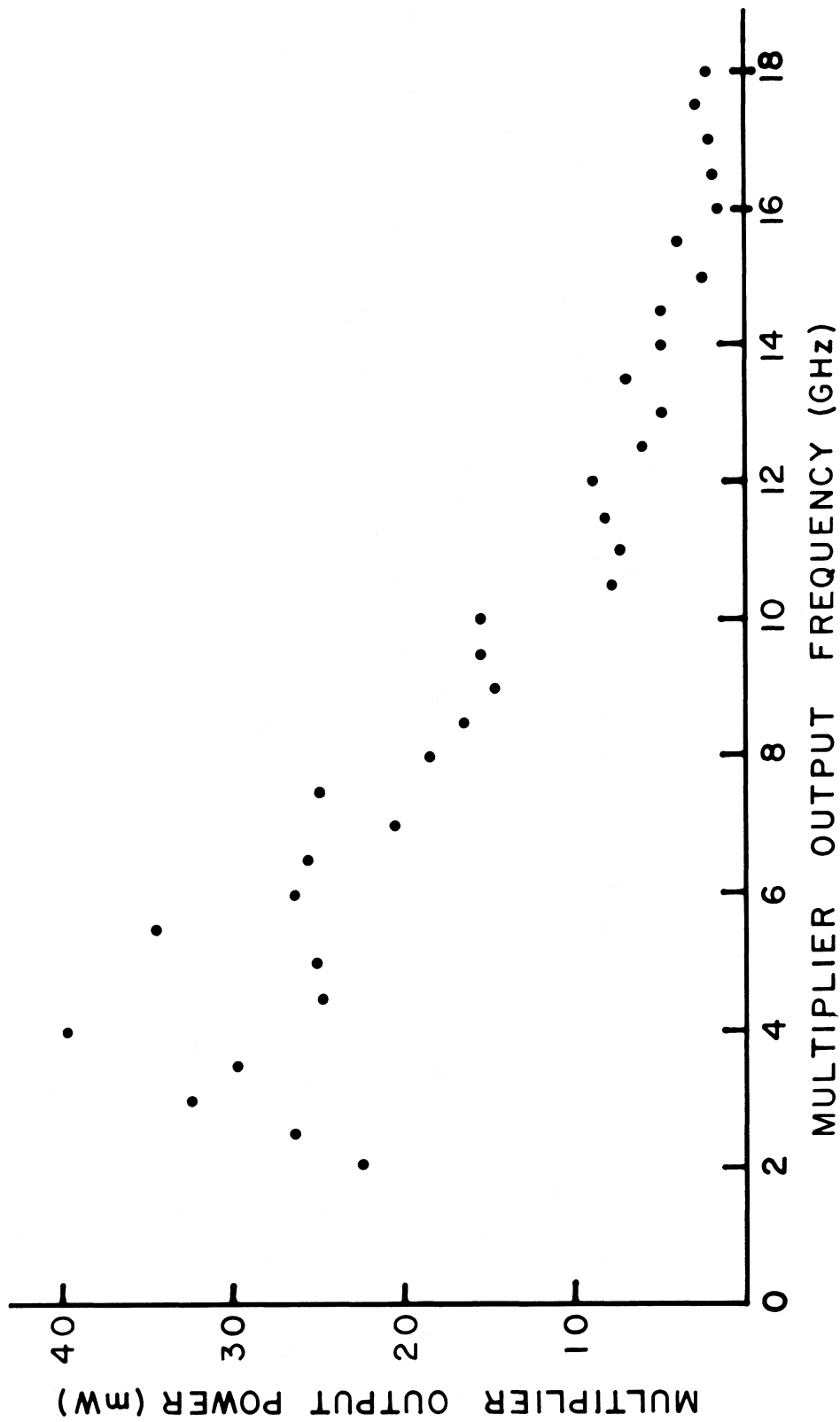

Figure 4. Multiplier Output Power measured at the Type N Output Connector on the Multiplier Chassis.

TABLE 1

Thumbwheel Switch Logic for Multiplier (13) and UL0 (17)
Frequency Controls

Truth Table 13

DIAL	COMMON C CONN. TO TERMINALS:			
	1	2	4	8
0				
1	●			
2		●		
3	●	●		
4			●	
5	●		●	
6		●	●	
7	●	●	●	
8				●
9	●			●

BINARY CODED DECIMAL, ONE COMMON

Standard Dial: 0-9

10 Positions

Series	Symbol	Part Number	Terminations	List Price
200		201	WL	17.00
300	③	378	S or DC1	6.00
	*	315	S or DC1	7.00
		3669	WW	8.00
	③*	3800	WW	9.00
700		701	S or DC27	10.00
		701/107	S or DC27	12.00
	*	715	S	12.00
	*	715/107	S	14.00
8000	③	8078	S or DC8	5.00
	*	8015	S or DC8	6.00

TRUTH TABLE 13 (continued next column)

Truth Table 17

DIAL	COMMS. X (●) & Y (○) CONN. TO TERMINALS:			
	1	2	4	8
0	○	○	○	○
1	●	○	○	○
2	○	●	○	○
3	●	●	○	○
4	○	○	●	○
5	●	○	●	○
6	○	●	●	○
7	●	●	●	○
8	○	○	○	●
9	●	○	○	●

BINARY CODED DECIMAL, WITH SEPARATE
COMMON TO NOT-TRUE BITS

Standard Dial: 0-9

10 Positions

Series	Symbol	Part Number	Terminations	List Price
200		211	WL	18.00
300		311	S or DC1	10.00
	*	3773	WW	12.00
700		711	S or DC27	13.00
		711/107	S or DC27	15.00
8000		8011	S or DC8	7.00
9000		9011	S or DC1	14.00
	*	9773	WW	16.00
12000		12011	S	17.00
13000		13011	S or DC1	10.00
	*	13773	WW	12.00
19000		19011	S or DC1	11.00
	*	19773	WW	13.00
23000		23011	S	3.75
		23119	S or DC	4.00
29000		29011	S	4.50
		29159/x	P or WW	5.25

TABLE 2

D/A Converter YTM Control Alignment

1. Set "Multiplier Frequency" to 02.00 GHz.
2. Ground point A.
3. Adjust R_1 for zero volts at point B.
4. Adjust R_2 for zero volts at point C.
5. Adjust R_4 for zero volts at point D.
6. Remove ground from point A.
7. Set "Multiplier Frequency" to 18.00 GHz.
8. Adjust R_3 for 9.942 volts at point D.
9. Set "Multiplier Frequency" to 10.00 GHz.
10. Record voltage at point D.
(Should be close to 5.000 V.)
Call this reading V_1 .
11. Set "Multiplier Frequency" to 11.00 GHz.
12. Record voltage at point D.
(Should be close to 5.625 V.)
Call this reading V_2 .
13. Compute $V_1 + 0.99 (V_2 - V_1) = V_3$.
14. Set "Multiplier Frequency" to 10.99 GHz.
15. Adjust R_5 so voltage at point D is equal to V_3 .
16. Double check by going through 1-15 again.

1 W into the multiplier. The external level monitor sensitivity depends on the external coupling ratio and detector, but at 18 GHz a 16 dB coupling ratio (10 dB directional coupler and 6 dB pad) with an HP 8472A detector produces about 0.5 V output with 2 mW of RF power from the multiplier. The drive or output monitor signals can be used to automatically stabilize the output power.

The D/A converter circuit is designed to accept 4 digits of complementary BCD data to specify the multiplier frequency in steps of 0.01 GHz. The YIG filter has a bandwidth of about 0.03 GHz so the 4 digit accuracy is sufficient. The multiplier tunes from 2 to 18 GHz with a 0 to 10 V control range so IC3 in Figure 3 is offset for 0 V output with 02.00 GHz digital input and R3 is adjusted for about 10 V output with 18.00 GHz input. The exact gain depends a bit on the individual YIG unit. The gain of IC4 is adjusted for 1% of the gain of IC3 for the tenths and hundredths digits. The complete alignment procedure is given in Table 2.

For automated operation the digital tuning data could be supplied by a computer, but for now only manual local and remote control are provided through thumbwheel switches. One set of switches is mounted on the multiplier chassis in the transmitter tower and another set in the remote control panel in the receiver hut. The two sets are tied in parallel with common pull-up resistors so one set must be dialed to "00.00" while the other is in use. Truth Table 13 in Table 1 shows the switch logic.

While the YIG multiplier tuning is nearly linear it is not perfect. The linearity specification is $\pm 0.1\%$ which translates into ± 0.01 GHz at 10 GHz. The unit used here appears to meet this specification everywhere except the high end of the tuning range. The control circuitry was aligned to minimize the error over the whole tuning range, and as a consequence there is an error of about ± 0.04 GHz in the multiplier frequency setting. In any case the multiplier

stetting should be tuned over a few tens of MHz around the output frequency to obtain the maximum output power.

Figure 4 is a plot of the multiplier output power measured every 0.5 GHz over the tuning range with a drive level of 700 mW. There is quite a bit of fine scale structure on the order of ± 2 dB in the YIG filter passband so the output power is quite frequency sensitive unless it is controlled with an external leveling loop.

The Remote Control Unit

The complete schematic of the remote control unit in the receiver hut is given in Figure 5, and a functional schematic of the ULO frequency control section is shown in Figure 6. The remote multiplier frequency control and level monitor circuits duplicate and are in parallel with their counterparts in the multiplier chassis. The connector pin configuration for the multiconductor cable between the receiver hut and the transmitter tower is called out in Table 3. This cable passes through a terminal strip in the receiver hut.

At the present time the only synthesizer derived 1 to 2 GHz source available in the lab is the spare ULO system. This system uses an HP 5105 RF synthesizer to generate a 250 to 500 MHz signal which is multiplied to the 1 to 2 GHz band by a tracking YIG tuned multiplier. The multiplier unit is described in EDIR #167 by B. Mauzy, and the synthesizer frequency control interface is described in EDIR #144 by D. Schiebel. The control interface was designed for control of the ULO by the telescope computers.

There are 3 switch selectable, 10-digit synthesizer frequency control registers in the control interface unit. Only one, "F_{LO}", is used with the antenna range source. The 10-digit registers are loaded 4 digits at a time through a BCD 16-bit input bus which uses TTL, 1 = Low, logic. The loading

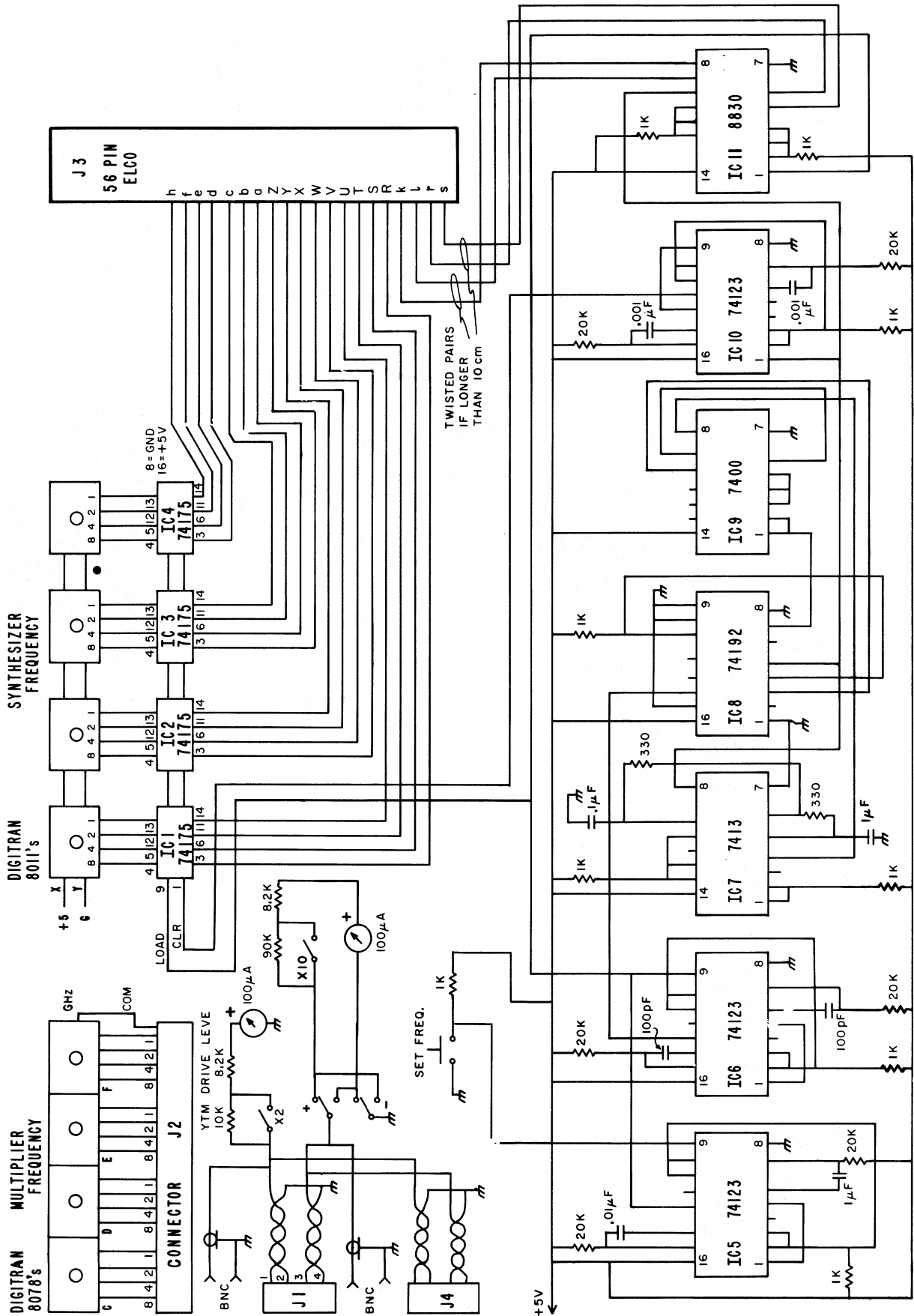

Figure 5. Remote Frequency Control and Multiplier Monitor Unit (receiver hut).

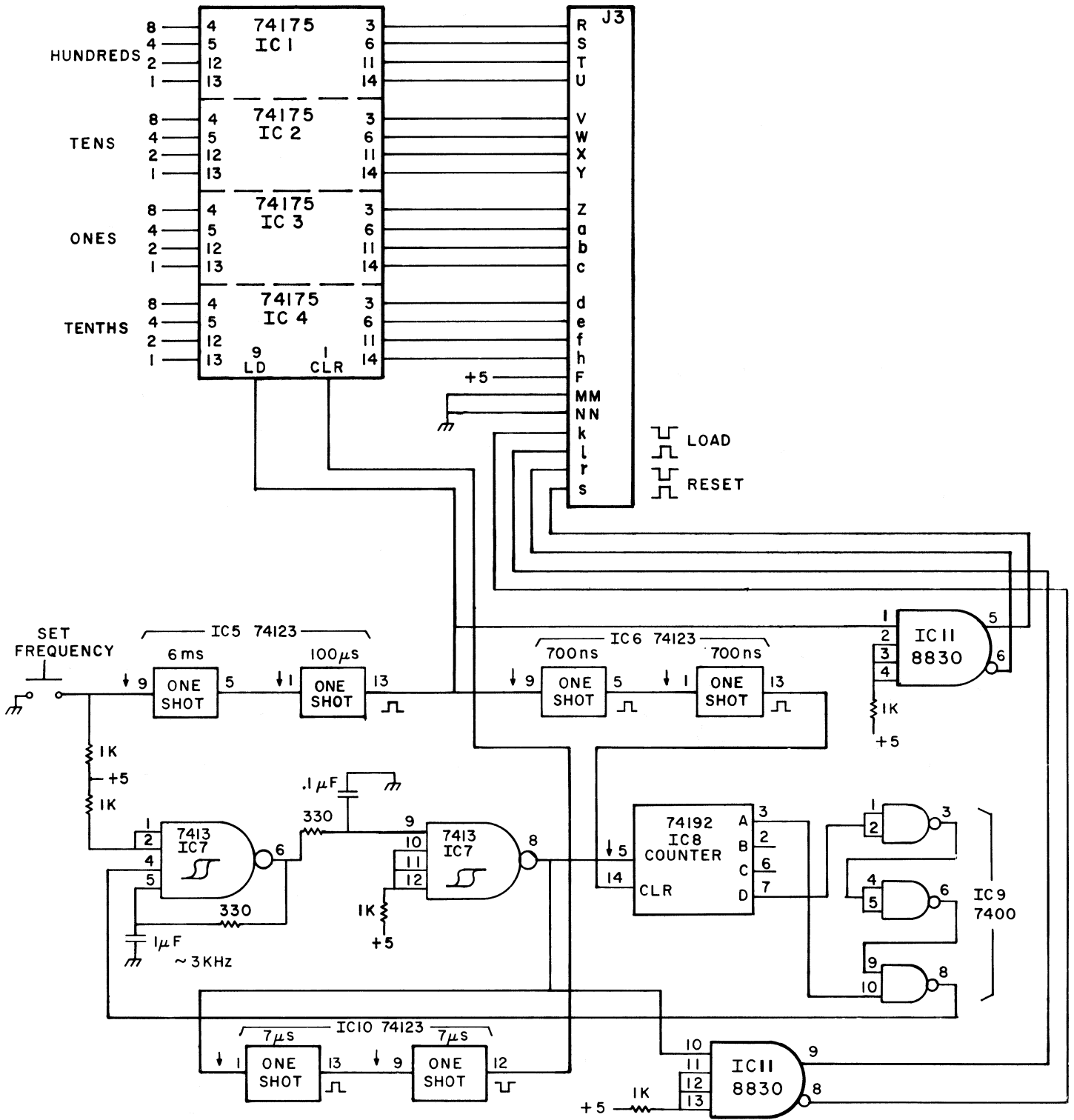

Figure 6. Functional Diagram of ULO Frequency Control Circuit from Figure 5.

TABLE 3

YIG Multiplier Control and Monitor Cable
(Receiver Hut to Transmitter Tower)

Function	Receiver Hut Control Panel	Receiver Hut Terminal Strip	Multiplier Chassis
	P2-J2		P2-J2
MSB ↑	A	1	A
	B	2	B
	E	3	E
	F	4	F
4-Digit BCD Multiplier Frequency Data	L	5	L
	M	6	M
	R	7	R
	S	8	S
	W	9	W
	X	10	X
	AA	11	AA
	BB	12	BB
	CC	13	CC
	DD	14	DD
	JJ	15	JJ
↓ LSB	MM	16	MM
Gnd	NN	17	NN
	P1-J1		P1-J1
Drive Level	A	18	A
Gnd	B	19	B
Ext. Level	C	20	C
Gnd	D	21	D

TABLE 4

Synthesizer Remote Control Cable
(Receiver Hut to Lab Building)

Function	P3-J3 Receiver Hut	Twisted Pair Cables	Terminal Strips in Lab	ULO Plugs
MSB ↑ 4-Digit BCD Frequency Data ↓ LSB	R	<u>Red</u>	-A- 1	R
	S	<u>Green</u>	2	S
	T	<u>Black</u>	3	T
	U	<u>Green</u>	4	U
	V	<u>Black</u>	5	V
	W	<u>Blue</u>	6	W
	X	<u>Black</u>	7	X
	Y	<u>Yellow</u>	8	Y
	Z	<u>Black</u>	9	Z
	a	<u>Brown</u>	10	a
	b	<u>Black</u>	11	b
	c	<u>Orange</u>	12	c
	d	<u>Red</u>	13	d
	e	<u>White</u>	14	e
	f	<u>Black</u>	15	f
	h	<u>Red</u>	16	h
	j	<u>Black</u>	17	
	l	<u>White</u>	18	
+5 V	E	<u>Red</u>	-B- 1	F, H, L
Gnd	F	<u>Green</u>	2	
Gnd	MM	<u>Black</u>	3	MM, A, B, C, D
Load-	NN	<u>Green</u>	4	NN, E, J, K
Load+	k	<u>Black</u>	5	k
Reset-	l	<u>Blue</u>	6	l
Reset+	r	<u>Black</u>	7	E
Gnd	s	<u>Yellow</u>	8	F
Gnd	A	<u>Black</u>	9	MM
Gnd	B	<u>Brown</u>	10	NN
	C	<u>Black</u>	11	
	D	<u>Orange</u>	12	
	H	<u>Red</u>	13	
	J	<u>White</u>	14	
	L	<u>Black</u>	15	
	M	<u>Red</u>	16	
	N	<u>Black</u>	17	
	P	<u>White</u>	18	

P2-J2

P3-J3

Tied at plugs

sequence is as follows:

- 1) Transmit a reset pulse to set the loading counter to zero.
- 2) Put the 10^2 , 10^1 , 10^0 , 10^{-1} MHz digits of the first register on the 16-bit bus.
- 3) Transmit a load pulse.
- 4) Put the 10^{-2} , 10^{-3} , 10^{-4} and 10^{-5} MHz digits on the 16-bit bus.
- 5) Transmit a load pulse.
- 6) Continue until 9 words of 4 digits each are loaded. When the ninth word is loaded the commanded frequency is presented to the synthesizer. Note that the last two digits of the third, sixth, and ninth words are ignored since they do not fit in the 10-digit registers.

Since 0.04% frequency resolution is sufficient for the antenna range only 4 non-zero digits are transmitted from the remote control unit. Referring to Figure 6, the synthesizer frequency loading sequence is started by the "Set Frequency" button on the remote control panel. The output pulse from IC5 appears on the "reset" line at the same time that it strobes the BCD information into latches IC1-4 which have their complementary outputs connected to the 16-bit data bus. (See Table 1 for thumbwheel switch logic.) After the latch strobe and ULO reset pulses have terminated, a sequence of 9 load pulses are initiated by clearing counter IC8 which starts the IC7 generator. The load pulses come from this generator, and after the first pulse the latches are cleared so all zeros are transmitted in the last eight words. After IC8 counts to 9 the load-pulse generator is turned off.

The connector pins for the ULO control cables between the receiver hut and the lab are called out in Table 4. These cables go through two terminal strips in the lab building.

Results

The noise on the amplitude and phase pattern plots made with the new signal source appears to be by about a factor of 4 less than that produced by the HP 8690 generator at around 15 GHz even though the latter had a somewhat higher output power. With the synthesizer derived source the receiver locks to the transmitted signal more quickly and shows no sign of losing lock as it often did with the HP 8690.

Figure 7 is an example of the phase and amplitude accuracy obtainable with the new system. The horn used to generate these patterns has a gain of approximately 10 dB over isotropic. Thus, the noise on the pattern becomes important in Figure 7 at about 26 dB below the isotropic reference. This is 14 dB above the ultimate receiver sensitivity predicted in an earlier section. Some of the noise in the pattern is undoubtedly due to parasitic currents on the antenna support structure.

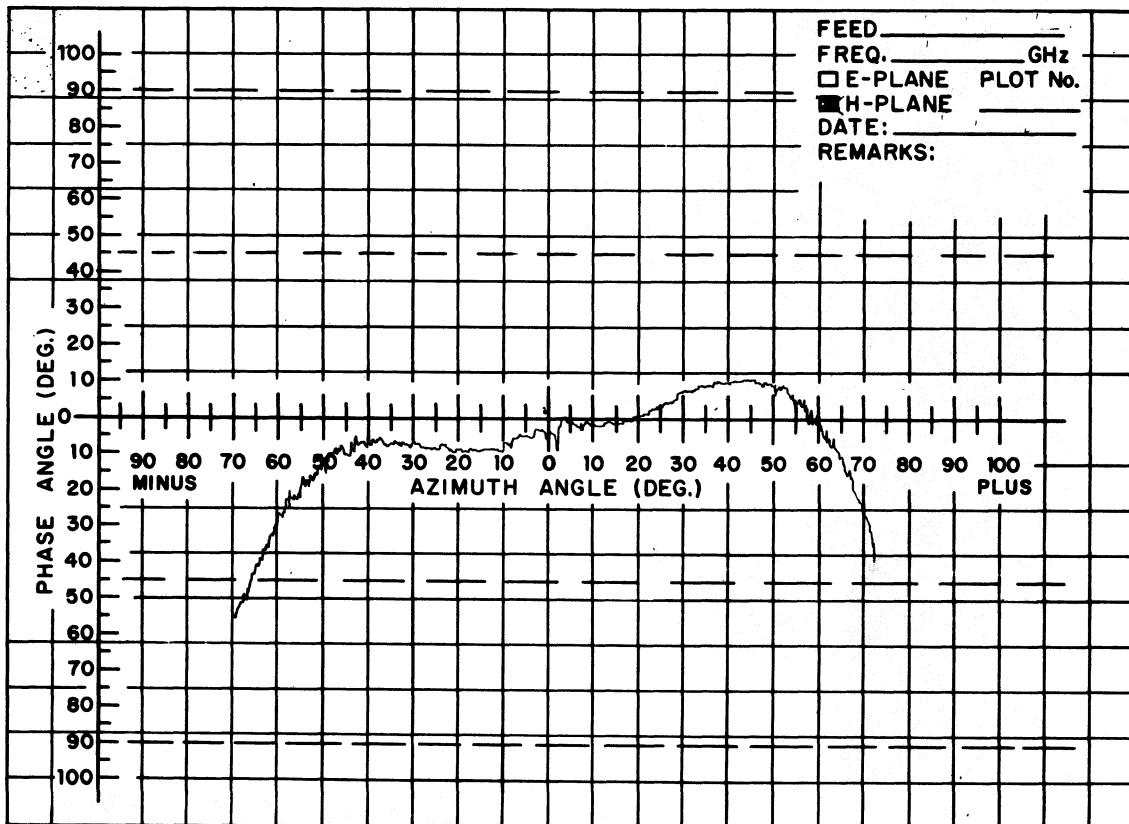
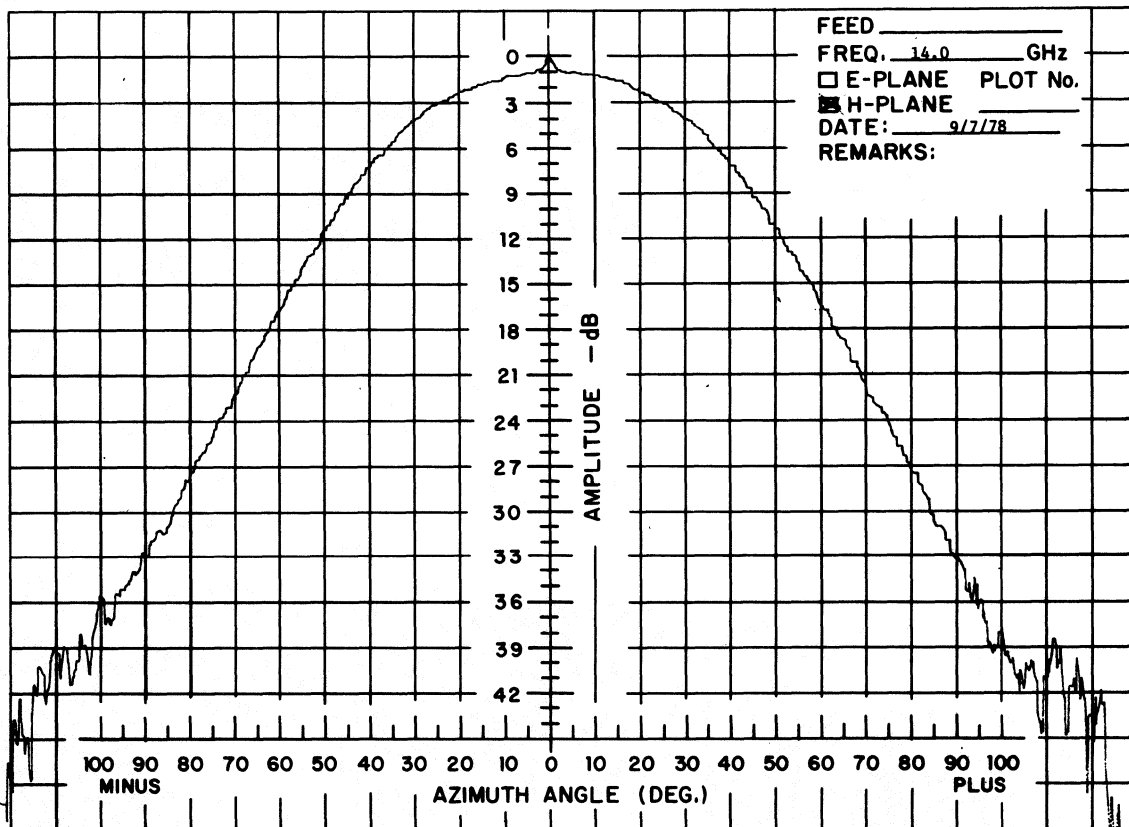

Figure 7. Typical Amplitude and Phase Patterns at 14 GHz with the YIG Tuned Multiplier Signal Source.