

NATIONAL RADIO ASTRONOMY OBSERVATORY
CHARLOTTESVILLE, VIRGINIA

ELECTRONICS DIVISION INTERNAL REPORT No. 192

AN AUTOMATED MIXER TEST SET

MICHAEL K. JONES
(SUMMER STUDENT)

AUGUST 1978

NUMBER OF COPIES: 150

I. Introduction

This report describes the design and operation of an automated mixer test set. At present a partially complete version of the set has been tested. A discussion of the present components of the system and recommendations for completion of the system are included.

The test set is to be used to obtain real time measurements of mixer noise temperature and conversion loss. These two values will be displayed to the test operator as he adjusts the mixer. This will allow adjustment for optimum performance of the mixer.

II. General Layout of the System

The system consists of three sections (Figure #1). The first provides the hot and cold loads for the mixer and logic signals with which to control the other two sections. The second section is the previous test set up. A receiver processes the signal from the mixer and produces an analog output which is directly proportional to the noise temperature at its input. This section also contains a noise diode to determine mixer-receiver mismatch and a resistive load to determine receiver gain variations. The third section is a digital back-end which integrates and digitizes the analog output of the receiver, processes the data, and displays the mixer noise temperature and conversion loss.

III. Present Test Set Hardware

A. The first section consists of a chopped hot/cold load, photo-detectors and the digital logic to generate the synchronizing control signals (Figure #2).

The chopper wheel is driven by a speed controlled motor. The speed is controlled by a continuous dial adjustment. The wheel (Figure #3) is divided into four 90° sectors. Therefore, there are two diametrically opposite pairs of sectors. One pair of sectors carries the hot load on the outer part of the radius and is solid black metal on the inner part of the radius. The other pair of sectors is open to allow the feed horn of the mixer to see the cold load. When the feed horn is aligned with the chopper it must be looking at the outer radius so as to see the hot load, and cold load in sequence. The inner radius is used to chop between the light source and the photodetectors. The

light source is two miniature light bulbs which are mounted on the side of the chopper wheel support. The photodetectors are two phototransistors (GE L14G1) which are mounted opposite the light bulbs. The bracket in which they are mounted has a position adjustment for one of the photodetectors.

The cold load is in a styrofoam dewar with a plastic lining to prevent leakage. It contains the absorbing material in a bath of liquid nitrogen. The cold load is seen through the side of the dewar. The cold load should be placed on the opposite side of the dewar cavity from the feed horn. Tests have been performed which show that this arrangement gives no measurable difference within 1°K from holding a cold load (dipped in liquid nitrogen) in front of the feed horn. Part of the styrofoam has been cut away on one side of the dewar to allow the proper positioning of the dewar directly behind the chopper wheel and adjacent to the wheel support. A channel is cut in the styrofoam to allow the nitrogen gas which is boiling off to escape.

The digital logic of the first section must provide signals to synchronize the digital back-end to the chopper wheel and control the noise diode and resistive load switches of the second section. Therefore, the logic must provide the following information:

- 1) when the data should be read for processing
- 2) whether the data is from the hot load, cold load, noise diode, or resistive load
- 3) switching for the noise diode and resistive load
- 4) when the back end should ignore data from the receiver output.

This last information is needed so that the back-end is not gathering data when the feed horn beam is looking partially at a cold and partially at a hot load, that is when an edge of one of the 90° sectors splits the beam. Also, the back-end should not gather data during the switching time of the noise diode and the resistive load.

The photodetection and logic circuitry (Figure #4) is on a board (Figure #5). The logic is designed for timing a four phase cycle which obtains data from:

- 1) the cold load
- 2) the hot load
- 3) the noise diode with the cold load, and
- 4) the resistive load.

The START and STOP signals are high when the light is shining on the respective photodetectors (Figure #6). The BLANK signal is provided to keep the back-end from gathering data during transitions. The START and DIV2 signals are put into a decoder. They represent two binary bits which can be decoded into four signals to activate each of the four phases. The BLANK is high for a short period at the beginning of each phase. Its duration can be controlled by adjusting the position of one of the photodetectors (changing the phase relationship of the START and STOP signals). They should be spaced so that the angular distance between them is equal to or greater than the size of the beam falling on the chopper. It can be assumed that the chopper wheel will be running slowly enough that the BLANK signal will be more than long enough to cover the switching times of the noise diode and resistive load phases. With this set-up two of the phase signals can be used to activate the relay switches for the noise diode and resistive load. These two signals may need some processing (amplification, for instance) before being of use, depending on the requirements of the relay switches.

B. The second section consists of an i.f. amplifier, filters, detector, noise diode and resistive load. It is the previous test set. It can be calibrated so that the detected output is directly proportional to the noise temperature at its input connected to the mixer being tested. The switches for the noise diode and resistive load in this section are controlled from the first section. The analog output of the second section is used directly as input to the third section.

C. The third section is the digital back-end. It consists of a voltage to frequency converter for the data from the detector of the second section, a counter to integrate the converted data, a programmable processor to convert the raw data to noise temperature and conversion loss values, and a display for these values.

The voltage to frequency conversion is supplied by a Teledyne Philbrick 4707, 100 Hz to 5 MHz converter. The pulses from this converter are counted by the counter. Therefore, the number in the counter is proportional to the integrated voltage during a sampling period. To compare numbers the sampling period must be the same for each count. Therefore, the unblanked phases must be of equal period. The counter reading by the processor and resetting to zero is synchronized from the first section. After the data is read it is processed and displayed to the operator.

Until now, all of the back-end functions (and the decoding in the first section) have been provided by the digital radiometer developed at Green Bank (Electronics Division Internal Report #188), which includes a 4707 V/F Converter.

IV. Present Operation of Test Set

In order for the first section to provide the proper inputs to the mixer it must be set up carefully. The feed horn has a beam which increases in size with distance, that is, it is non-collimated. The loads must fill the beam for an accurate measurement. Therefore, the feed horn should be placed as close to the hot load on the chopper wheel as possible without having the chopper wheel rub against it. It should be placed so that the hot load covers the aperture of the feed horn.

The cold load in the dewar will then be some small distance from the feed horn. The dewar should be placed as close to the chopper wheel as possible without rubbing. Since the beam is larger than the feed horn aperture at this small distance away, it must be determined what the beam size and position is there. This can be done from the angular size of the beam at the aperture and the feed horn's position. The dewar is then positioned vertically so that the cold load in the cavity fills the beam size determined. No part of the beam should fall on anything but the cold load. Then, there will be a small horizontal adjustment of the dewar to center the beam on the load. This can be done by looking at the detected output and moving the dewar until the temperature is the lowest. These adjustments must be done to obtain correct cold load readings. Also, care must be taken not to allow the liquid nitrogen level to drop too far when taking measurements.

The operation of the second section is as it has been. It must be calibrated before measurements start.

The digital radiometer that has been used must be connected to the logic signals of the first section. The inputs to the Digital Standard Receiver Mark III to externally synchronize it are on the back panel and are accessed by putting the switch on the front panel to EXT (refer to Internal Report #188). They are termed S/R, CAL and BLANKING. The BLANK signal should be connected to the BLANKING input. The CAL and S/R inputs go to a decoder to give phase signals.

The phases are numbered 0 to 3 and the decoder works as in Table #3. The sequence of these phases can be varied by various connections to the CAL and S/R inputs of the START, START, DIV2 and DIV2 signals.

V. Recommendations for Future Work

1. Test the system further with the digital radiometer. There must be changes in the "READ RCVR" program to allow real time input of the four phases of data (refer to Report #188). A program will have to be written to process the data and give uncorrected noise temperature and conversion loss figures (see discussion of programming in recommendation #6).

2. Decide what the permanent back-end of the system will be.

3. Devise a biasing circuit for the 4707 V/F Converter. It may be easiest to obtain the circuit from the bias design of the 4707 in the digital radiometer.

4. If it is necessary for the chosen back-end, design a counter for the converter output. The 30 MHz counter design in March 1978, Radio Electronics could be modified for this purpose.

5. Decode the logic signals to give the four phase signals. Circuitry for this and the counter should be added to the board which has the previous logic circuitry on it to minimize the number of components and wires in the overall system.

6. Program the back-end to allow synchronizing from the logic circuitry data processing, and display.

The processing program must convert the four phases of data to corrected values for conversion loss and noise temperature. The equations for such a conversion are as follows:

$$L_C = \frac{2*DT_{CAL}}{T_H - T_C}$$

$$Cl = \frac{T_{RC} - T_C}{DT_{REFL}} = \frac{T_{RH} - T_H}{DT_{REFL}}$$

$$C2 = \frac{1}{1 - C1}$$

$$L_C^* = \frac{L_C}{C2}$$

$$TMXR = (T_C - (T_{IF})(C1))(L_C) - 2^*T_{IN}$$

where:

- L_C - uncorrected conversion loss
- DTCAL - difference between the actual temperatures of the hot and cold loads
- T_{RC} - temperature measured when noise diode is on and mixer is looking at cold load
- T_{RH} - temperature measured when noise diode is on and mixer is looking at hot load
- T_C - temperature measured when mixer is looking at cold load
- T_H - temperature measured when mixer is looking at hot load
- DTREFL - difference between temperatures measured with the noise diode on and off, both with no mixer connected to the input, that is, with an open circuited input
- C1 and C2 - correction factors for mismatch at i.f. port
- L_C^* - conversion loss corrected for i.f. port mismatch
- TMXR - mixer noise temperature corrected for mismatch at i.f. port
- $T_{IF} = T_{NOISE\ BOX}$ - i.f. input noise temperature excluding mixer
- T_{IN} - actual temperature of cold load

L_C^* and TMXR may be corrected for variations in the gain of the receiver. This is done through the use of the data received in the resistive load phase. T_H , T_C and T_{RH} (or T_{RC}) are the other three phases of data. DTREFL, DTCAL, T_{IF} , and T_{IN} have to be entered into the processor before measurements begin. After all of the above is done, the program will yield the corrected values which should then be sent to be displayed.

It may be that the data should be processed at the end of each four phase cycle (as a new cycle starts) or the data can be integrated over a number of cycles by adding together raw data values for each respective phase over these

cycles (being careful not to overflow the memory). Then the processing can be done.

7. Install the necessary electronics for switching the noise diode and resistive load. It may be possible to put this circuitry on the logic circuitry board. When it is decided that all the circuitry that will be on the board is finished, the board should be put into a box and fastened down.

8. It may be desirable to minimize the angular size of the feed horn or use a lens. This will reduce the beam size everywhere. This leaves a greater margin of alignment in which the loads fill the beam.

9. This is the basic operable system. It can be tested to see if appropriate values of noise temperature and conversion loss are being measured. If not, now is the time to work out system problems.

10. Design and install a lens and quasi-optical filter. The lens is to collimate the beam and allow the filter to work. The lens is placed directly in front of the feed horn. The lens size and placement will determine the size of the collimated beam.

The quasi-optical filter is aligned in the beam of the lens. It is used to limit the bandwidth of the beam. It is a Fabry-Perot type filter and must be mounted so that the distance between the meshes is adjustable. The meshes which are to be mounted are already provided. There are drawings of mounts for other filters available. These may be adapted for mounting the meshes. An optical translation stage (such as the ATS 301) can be used as the adjustment for mesh separation.

With these added components the bench set-up must emphasize conservation of space. The feed horn to load path length through the lens and quasi-optical filter should be as short as possible. The lens will not collimate the beam perfectly. Any deviation will increase the size of the beam. The shorter the path length the easier it will be to properly align the filter and assure that the loads are filling the beam. Getting the filter aligned correctly could be difficult and should be done carefully.

11. Test the system's performance. It may be ready for use.

12. It is possible to have a hot load in an oven with the proper modification of the system. The area now used as the hot load would be a reflector used to direct the beam to the oven. The lens, filter and feed horn would have to be angled to the chopper wheel face in order to allow reflection back to the oven (Figure #7). This design introduces two problems: 1) the beam size will be increased at the chopper because of oblique incidence, and 2) the path lengths to both the hot and cold loads will be increased which then brings the problems discussed above. This should only be tried if it is decided that more accuracy is needed in the noise temperature and/or conversion loss readings.

Extra parts for optical sensing system, the miniature light bulbs and the phototransistors, are here if problems develop with the ones in the system. Two smaller pieces of metal, the same as the metal on which the chopper wheel is mounted, are available to use to bring other parts of the test set to the level of the chopper wheel.

VI. Testing and Results

An initial test was performed with the present system set up. No programming was done on the digital radiometer. The test was performed in the usual manner, including calibration of the receiver. The 150 GHz mixer #4 with a 2 micron diode and 10 mil. whisker was tested. Four numbers were read in, using the hot-cold load chopper, the noise diode, and the resistive load. The numbers are labeled REFL, CAL, HOT and COLD (Tables 1 and 2). It is important to note that REFL was read with no mixer on the set (during the calibration of the receiver) with the noise diode on. CAL was read with the resistive load on. HOT and COLD were read with the respective loads as inputs to the mixer.

The results for both integration times of .1 sec. and .2 sec. (unless integration is done over a number of cycles when the system is complete, these may be longer integration times than will be used later) indicate that data can be satisfactorily read into the radiometer. It is apparent from the tabulated figures that the raw counts taken from the radiometer are directly

proportional to the temperatures taken from the receiver detector. No processing was done on the raw counts.

VII. Conclusions

So far as can be determined at present, there are no major problems with the system design. Tests have shown that the system should perform satisfactorily when complete. At present the test set-up is flexible and able to accommodate changes in the layout and addition of new components as changes in application call for them.

INPUT CAL	S/R	OUTPUT PHASE
0	1	0
0	0	1
1	1	2
1	0	3

Table 1. Code for digital radiometer decoder.

NUMBER OF RCVR CHANNELS= 1

SWITCH PERIOD IN MS = 50

BLANKING TIME MS = 0.0977

SAMPLES/INTEGRATION= 1

SAMPLE PERIOD (SEC)= 0.200

RCVR BAL TIME (SEC)= 1.000

DELTA T_{meas} SUMMATION TIME (SEC) = 1.000

Channel 1 CAL= 10.0000

Channel 1 BW= 50.0000

FOR CR 0
 CRSF= 1.00000
 FOR CR 1
 CRSF= 0.10000
 FOR CR 2
 CRSF= 10.00000
 FOR CR 3
 CRSF= 0.10000
 FOR CR 4
 CRSF= 1.00000
 FOR CR 5
 CRSF= 0.10000
 FOR CR 6
 CRSF= 10.00000
 FOR CR 7
 CRSF= 0.10000

DIGITAL OUTPUT SCALE FACTOR= 1.0000

Channel 1 S/R= 0.9973

REFL 272819
 CAL 50051
 HOT 50506
 COLD 48066

SIGNAL	COUNT	TEMPERATURE (°K)	COUNT/°K
REFL	272819	1626	167.8
CAL	50051	297	168.5
HOT	50506	299	168.9
COLD	48066	284	169.2

Table 2. Test #1: Radiometer settings and results.

NUMBER OF RCVR CHANNELS= 1

SWITCH PERIOD IN MS = 25

BLANKING TIME MS = 0.0977

SAMPLES/INTEGRATION= 1

SAMPLE PERIOD (SEC)= 0.100

RCVR BAL TIME (SEC)= 0.800

DELTA T)meas SUMMATION TIME (SEC) = 0.500

Channel 1 CAL= 10.0000

Channel 1 BW= 50.0000

FOR CR 0 CRSF= 1.00000
FOR CR 1 CRSF= 0.10000
FOR CR 2 CRSF= 10.00000
FOR CR 3 CRSF= 0.10000
FOR CR 4 CRSF= 1.00000
FOR CR 5 CRSF= 0.10000
FOR CR 6 CRSF= 10.00000
FOR CR 7 CRSF= 0.10000

DIGITAL OUTPUT SCALE FACTOR= 1.0000

Channel 1 S/R= 0.9984

REFL 280689
CAL 50155
HOT 56753
COLD 54261

SIGNAL	COUNT	TEMPERATURE (°K)	COUNT/°K
REFL	280689	1677	167.4
CAL	50155	297	168.9
HOT	56753	336	168.9
COLD	54261	321	169.0

Table 3. Test #2: Radiometer settings and results.

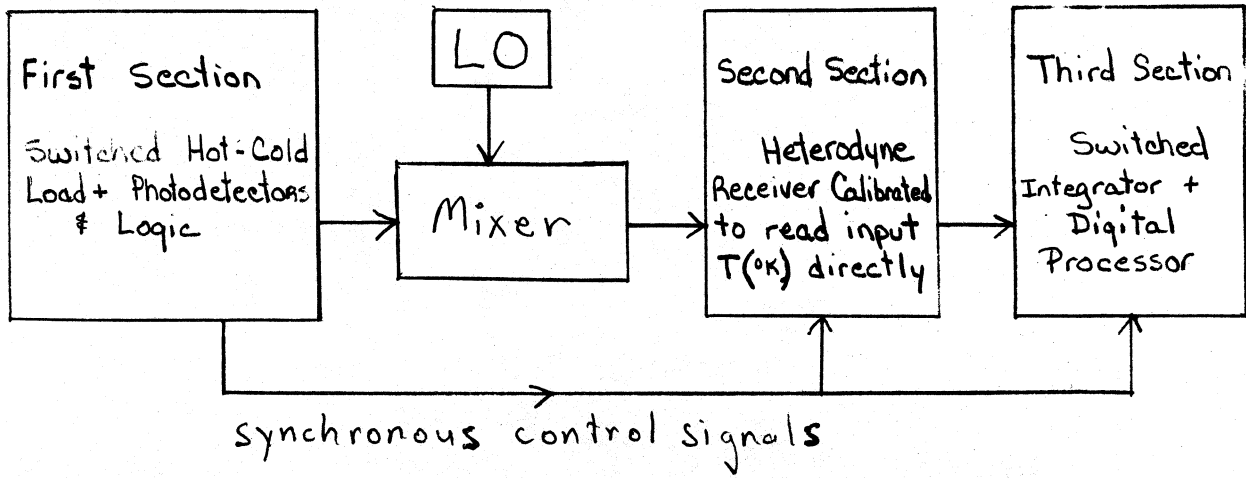

FIGURE 1. General System

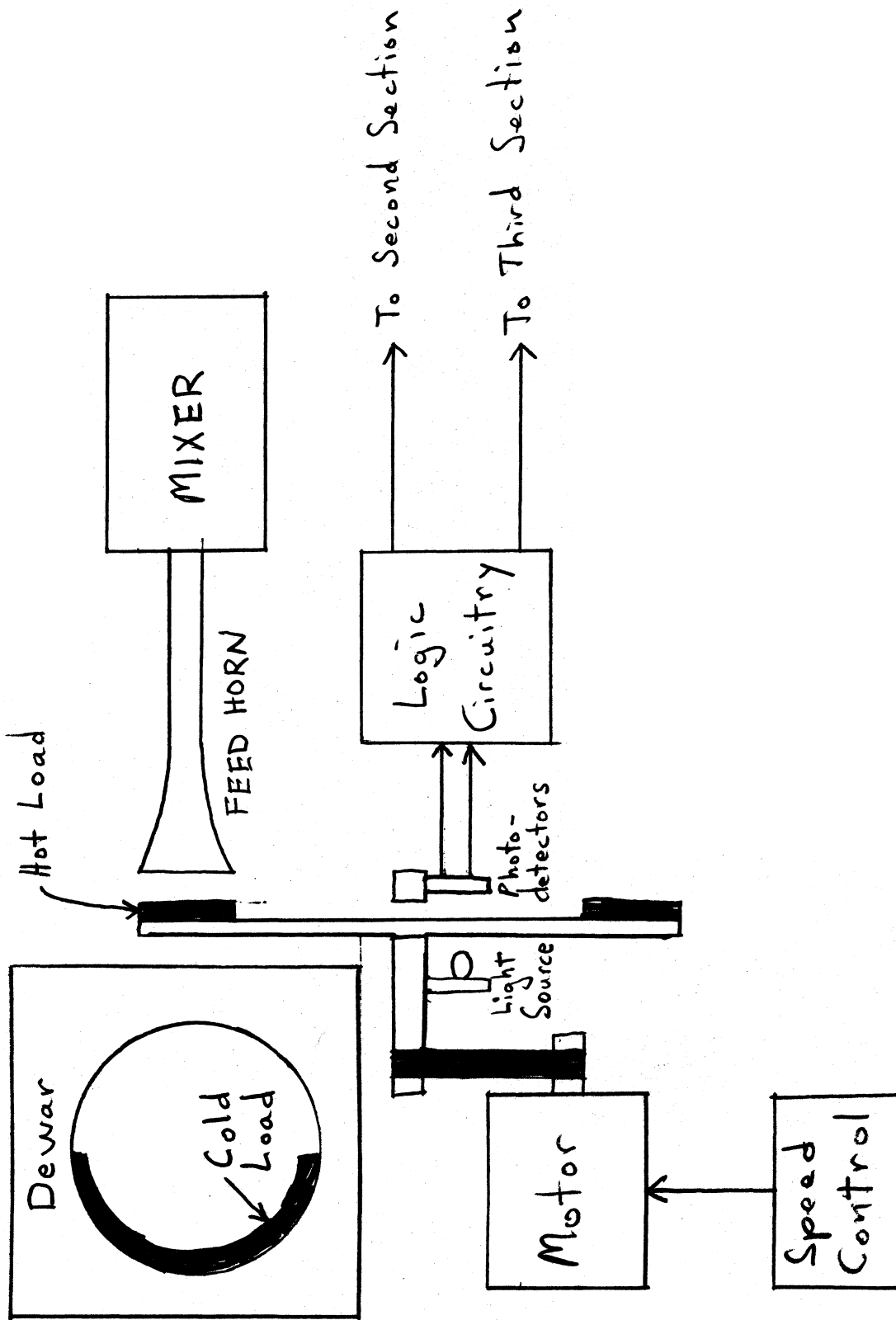

Figure 2. First section with mixer being tested.

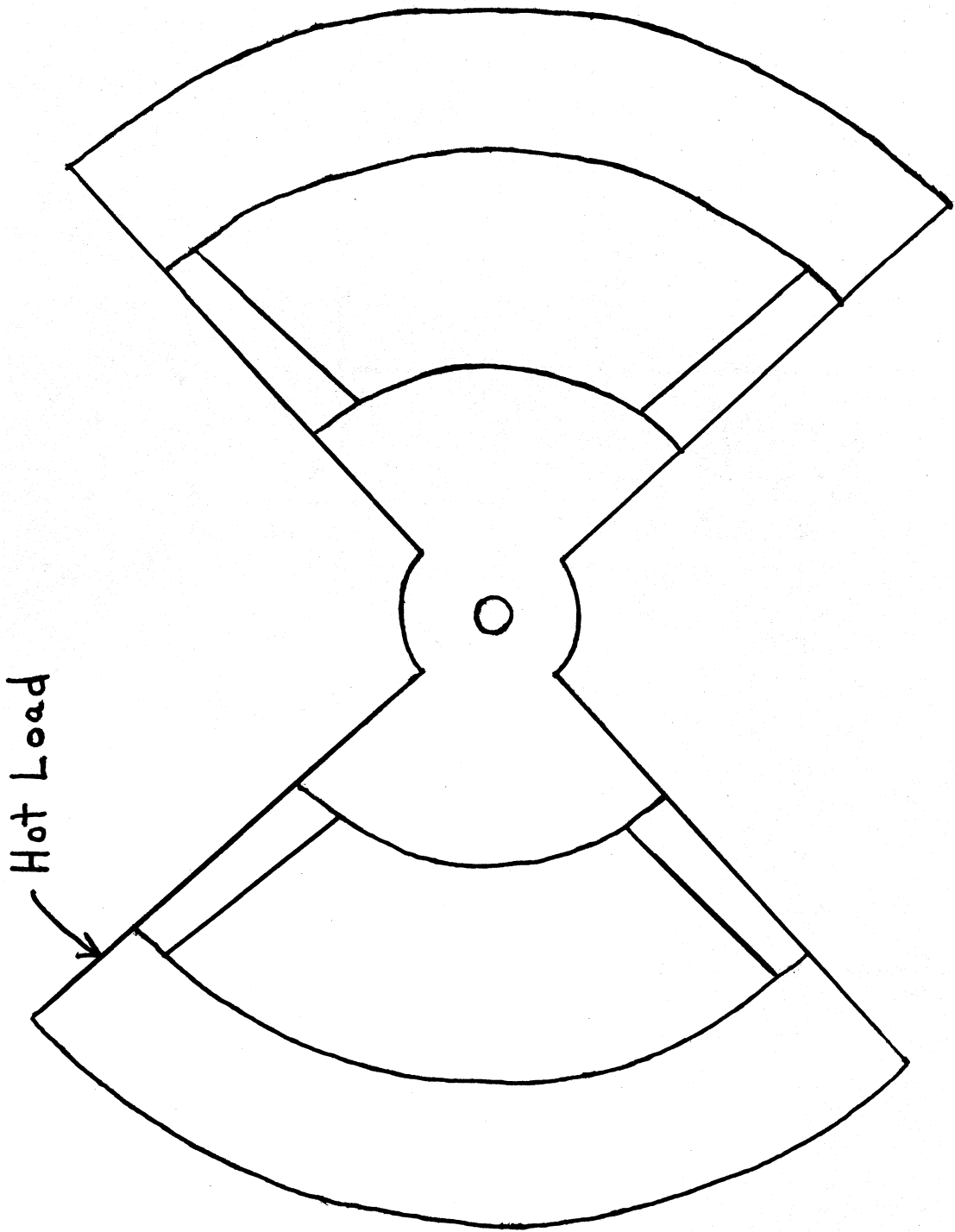

Figure 3. Chopper Wheel

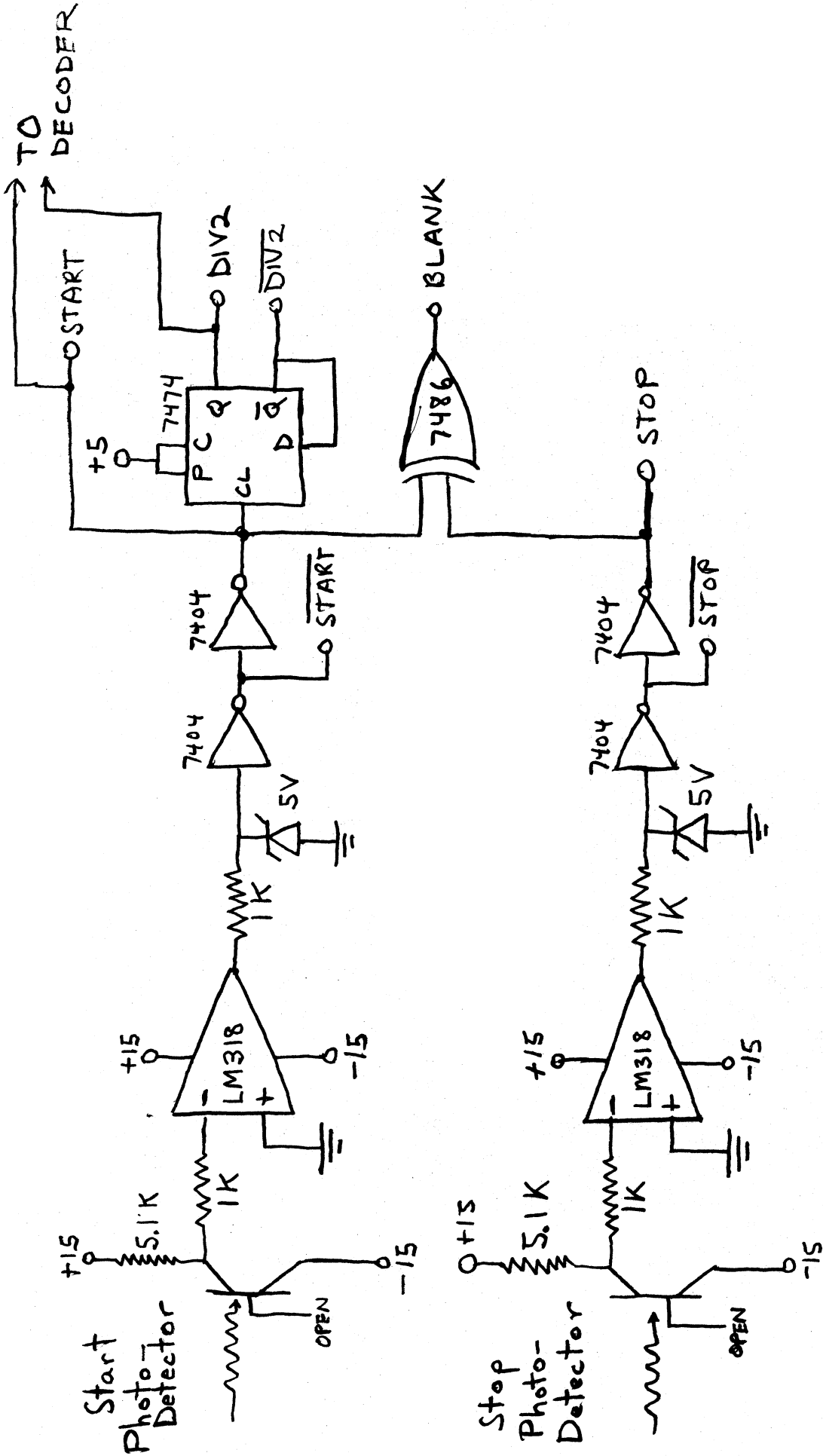
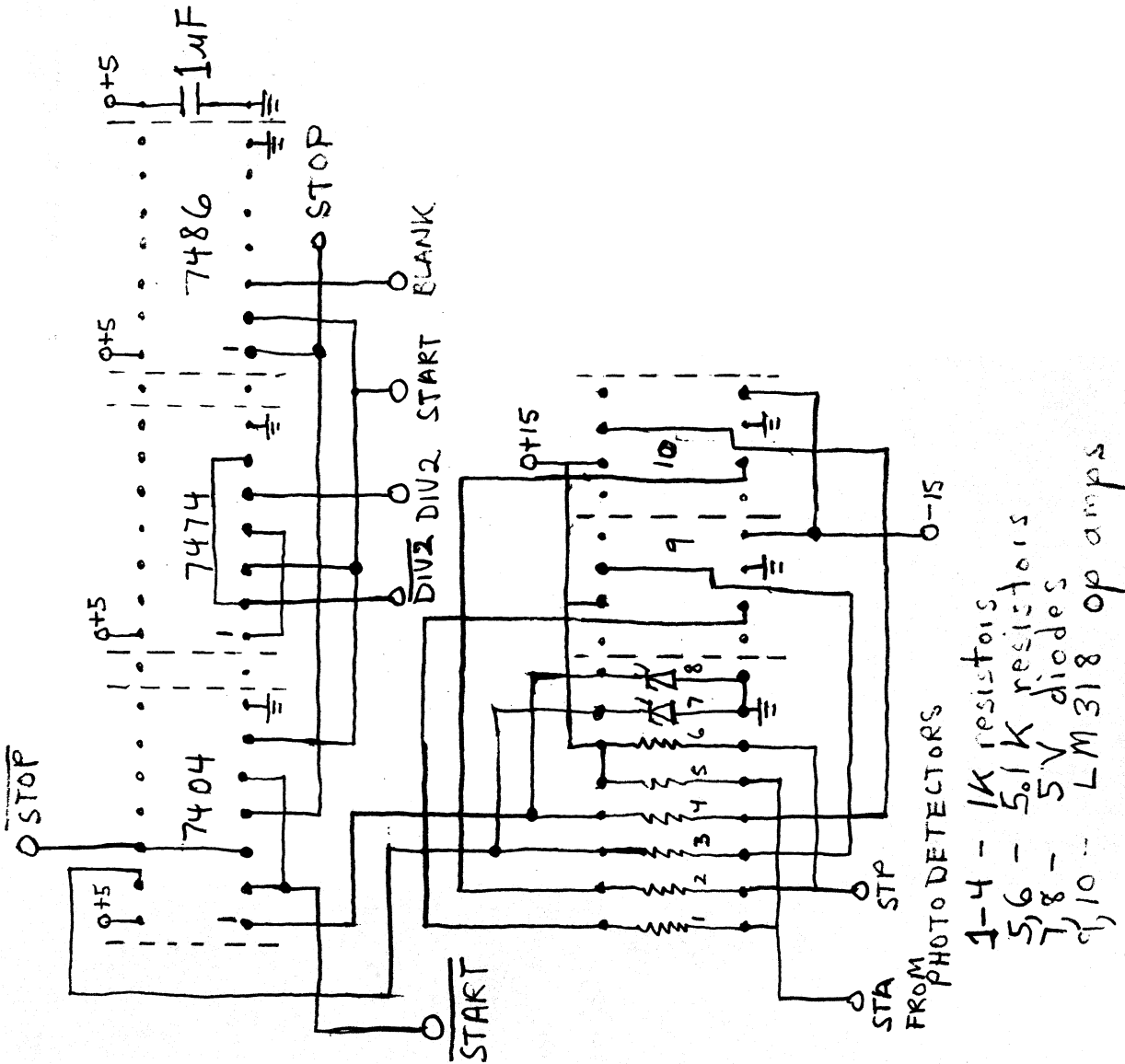

Figure 4. Photodetection and logic circuitry.



I/O

Signal	Connector #
+5	49A, 50A
GND	49B, 50B
+15	47A
-15	45A
STA	43A
STP	41A
START	39A *
START	37A *
STOP	35A *
STOP	33A *
DIV2	31A *
DIV2	29A *
BLANK	27A

* not currently being used

Color Code for Wiring on I/O

+5	ORANGE
GND	GREEN
+15	RED
-15	YELLOW
STA	GREY
STP	BLUE
START	BLUE STRIPE
DIV2	YELLOW STRIPE
BLANK	ORANGE STRIPE

Figure 5. Wiring and input/output of logic circuit board.

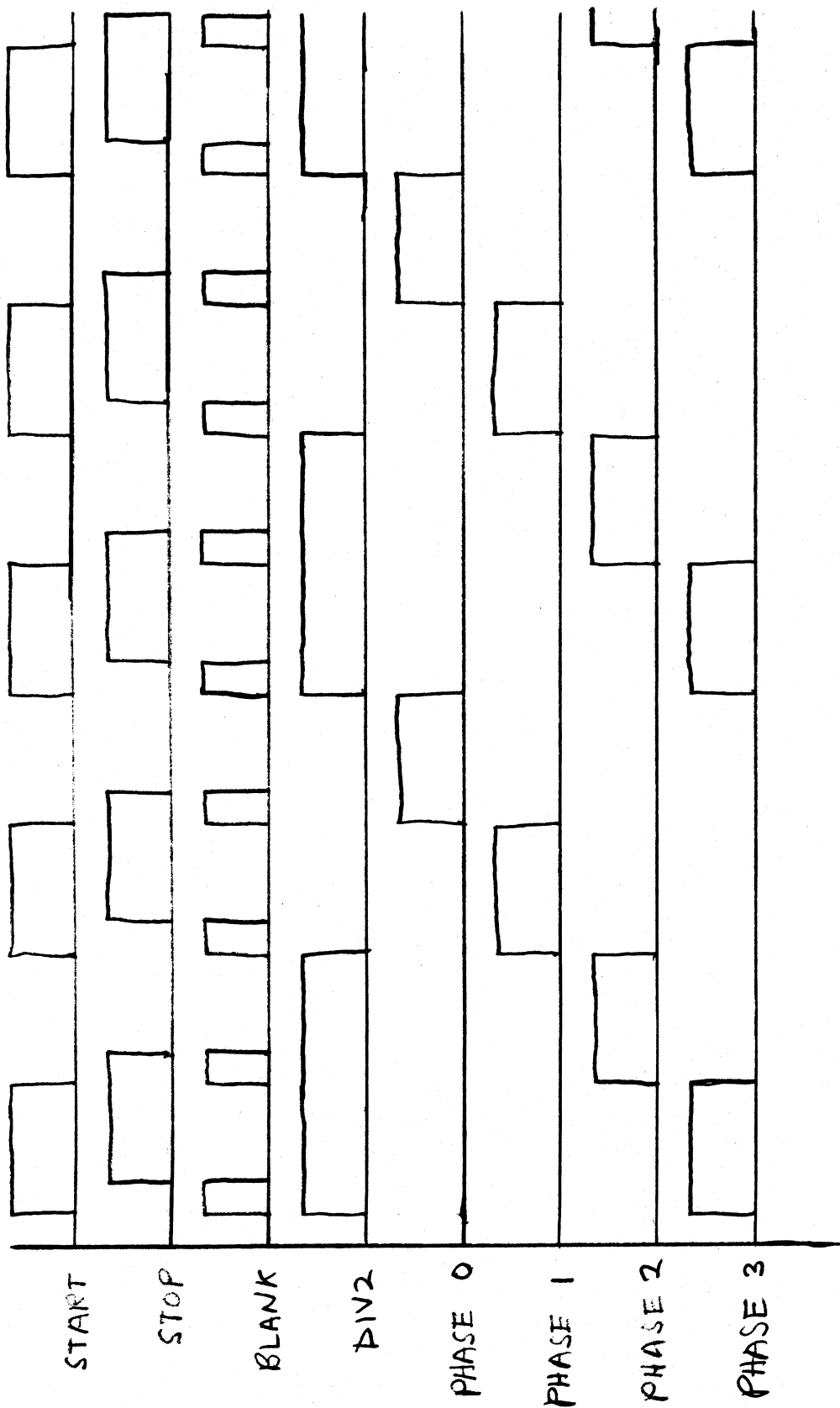

For DIV2 / START as inputs to decoder

Figure 6. Signals from logic circuitry.

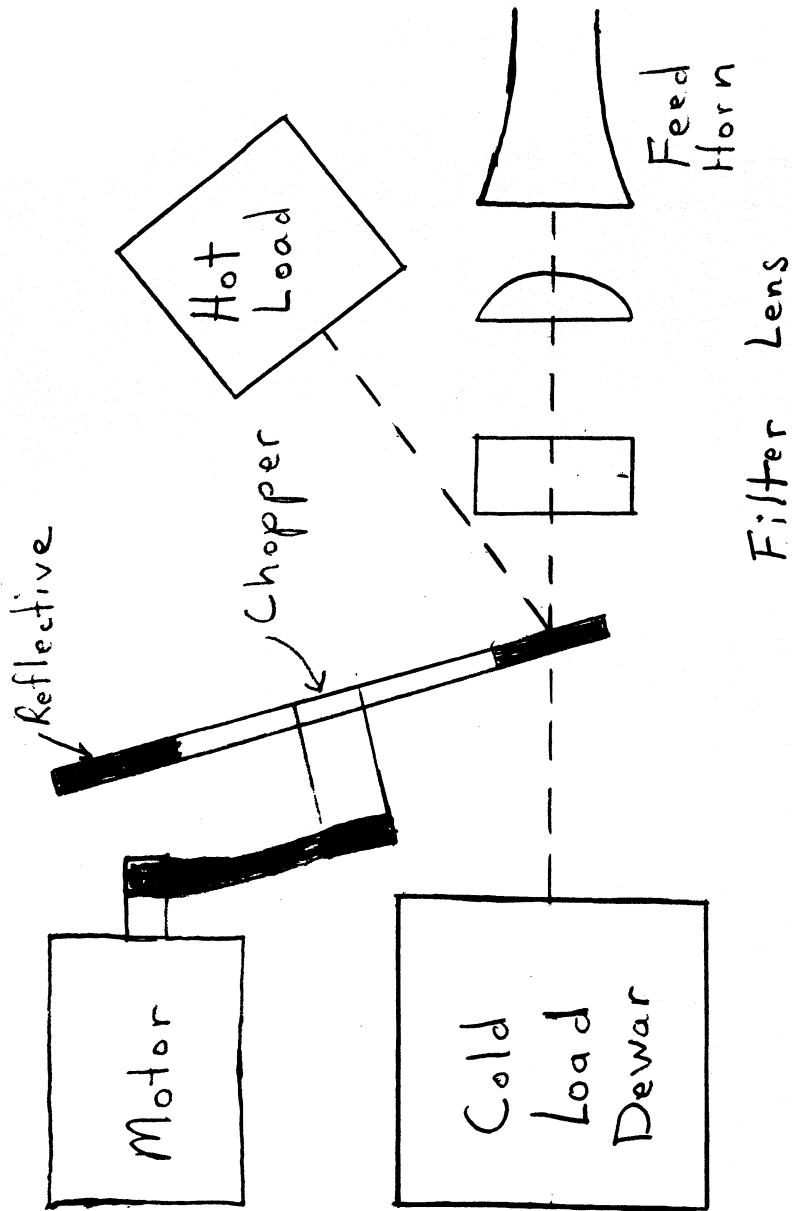

Figure 7. Possible set-up with hot load in furnace.