

NATIONAL RADIO ASTRONOMY OBSERVATORY
GREEN BANK, WEST VIRGINIA

ELECTRONICS DIVISION INTERNAL REPORT No. 180

NAIC RECEIVER

JAMES R. COE

OCTOBER 1977

NUMBER OF COPIES: 150

NAIC RECEIVER

TABLE OF CONTENTS

	<u>Page</u>
1.0 <u>General Information</u>	1
2.0 <u>Receiver System Components</u>	2
2.1 Dewar and Input Lines	2
2.2 Parametric Amplifiers	3
2.3 Upconverters	5
2.4 Diode Switch	5
2.5 RF and IF Components	6
3.0 <u>Receiver Control and Monitor</u>	7

FIGURES AND TABLE

Figure 1. NAIC Receiver Dewar Components	8
Figure 2. NAIC Receiver RF and IF Components	9
Table 1. NAIC Receiver Parts	10
Figure 3. Analog Monitor Block Diagram	11

NAIC RECEIVER

James R. Coe

FOREWORD

This report is a description of a receiver system developed for the National Astronomy and Ionospheric Center, Arecibo, Puerto Rico by the National Radio Astronomy Observatory at Green Bank, West Virginia.

The general design concept was taken from previous receivers assembled at NRAO. S. Weinreb and N. Conklin outlined the receiver requirements as specified in OAF-701, Agreement for Fabrication of a Multi-Frequency Receiver. The detailed design of the receiver system was done by J. Coe, G. Behrens, and G. Homer of NRAO. J. Oliver and W. Shank did the assembly and assisted in testing the system. A. Miano did the drafting and extensive layout work on the circuit boards. O. Bowyer designed the rack to house the receiver. The fabrication of the dewar, rack and chassis was done by the Green Bank machine shop personnel.

The first part of this report has been issued as Electronics Division Internal Report No. 180.

NAIC RECEIVER

1.0 General Information

The NAIC receiver is a dual channel system which can receive signals in the 4.5 to 5.0 GHz band or the 1.35 to 1.73 GHz band. In addition it can be operated with one channel receiving the 1.35 to 1.73 GHz band with the second channel covering the 1.0 to 1.45 GHz band.

The 4.5 to 5.0 GHz receiver first stage amplification is performed in a cooled parametric amplifier. The amplifier consists of two stages with a total gain of 25 dB. This paramp has an instantaneous bandwidth of 500 MHz. The receiver noise temperatures over the 4.5 to 5.0 GHz band are 30 to 40 K.

A diode switch is used to provide feed switching or feed load switching of the paramp inputs.

The 1.35 to 1.73 GHz amplifiers are cooled parametric upconverters. These units have gains of 3 to 4.5 dB with the pump frequency of 3.2 GHz. The output frequency is in the 4.55 to 4.93 GHz band and is routed through the diode switch to the parametric amplifiers. The minimum instantaneous bandwidth of the upconverters is 100 MHz. The receiver noise temperatures in the 1.35 to 1.73 GHz band are 17 to 25 K. The 1.0 to 1.45 GHz amplifier is also a parametric upconverter with a pump frequency of 3.5 GHz.

The first local oscillator is a phase locked unit which covers the frequency range of 3.24 to 3.74 GHz. It is locked to a +6 dBm signal over the frequency range of 810 to 935 MHz. The first IF frequency is centered at 1260 MHz with selectable bandwidths of 500, 200, 100, 50 or 25 MHz. The continuum output from the receiver is at this first IF frequency of 1260 MHz at a nominal level of -25 dBm.

The second local oscillator is at a fixed frequency of 1.0 GHz. The IF output is centered at 260 MHz with a maximum bandwidth of 100 MHz and power level of -27 dBm. This IF output is used for line observations.

A 50 MHz reference signal of +6 dBm must be provided to lock the upconverter pump oscillators and the 1 GHz second LO. A 50 Hz TTL level reference signal is required to synchronize the diode switch with the synchronous detectors.

2.0 Receiver System Components

The receiver system consists of a vacuum chamber or dewar, a closed cycle cryogenic refrigerator, and associated RF and IF components. The components and the interconnections are shown on the block diagrams in Figures 1 and 2 and identified in the parts lists shown in Table 1.

2.1 Dewar and Input and Output Lines

The dewar provides a vacuum chamber in which the cooled components and the cryogenic refrigerator are mounted. "O" ring seals lubricated with high vacuum grease are used on the input and output lines and the covers of the dewar. The "O" ring grooves are polished to 32 μ inch or better finish. Care must be taken during disassembly to avoid scratching the grooves or flat surfaces which the "O" rings seal against. Copper gaskets are used to seal the conflat flanges associated with the vacuum gauges and the evacuation port and valve. When the refrigerator is cold a vacuum of 10^{-5} torr or better is required to minimize heat transfer by gas molecules in the dewar. A radiation shield is attached to the 77 K stage of the refrigerator and surrounds the 17 K refrigerator stage and the cooled components. This shield substantially reduces thermal loading on the 17 K refrigeration stage by blocking radiation from the outside walls of the dewar.

To minimize thermal conduction the input and output lines are constructed of thin wall stainless steel tubing. The tubing is gold plated to reduce signal

losses. The 6 cm input waveguide to coax transitions are attached to the 77 K stage of the refrigerator. Stainless steel .141 inch O.D. coax is used to connect from the 6 cm WG/coax transition to the diode switch. The upconverter pump lines and the signal output lines are also made from stainless steel .141 inch coax. The type used is Precision Tube Type AN 50141.

When it is necessary to open the dewar the refrigerator should be turned off and the system allowed to warm up for at least six hours. Then dry nitrogen should be sprayed in the evacuation port as the valve is slightly opened until atmospheric pressure is reached. This helps prevent water vapor adsorption in the inner walls of the dewar and makes it easier to pump down. When changing parts in the dewar, care must be taken to prevent grease or other material from being left inside which would out-gas and make it difficult to maintain a vacuum.

If the dewar is clean and tightly sealed it can be pumped down to 1 millitorr and then closed off; then after 24 hours the vacuum should be 50 millitorr or less. The dewar volume is 50 liters and the leak rate is less than 2×10^{-5} std cc/sec.

After the dewar has been opened it is desirable to pump on it for at least 12 hours to get the vacuum down to 1 millitorr or less. Then the refrigerator is started. As the refrigerator cools down it freezes out-gas molecules and the vacuum should reach 10^{-6} torr or better when it is cold. The dewar port should be closed when the dewar vacuum approaches the blank off vacuum of the pump.

The paramps, upconverters and the diode switch are strapped to the refrigerator 17 K stage with OFHC copper brackets. Indium foil is used between all joints to assure good thermal conductivity.

2.2 Parametric Amplifiers

The 4.5 to 5.0 GHz paramps were developed by Airborne Instruments Laboratory, Inc. Each paramp consists of two modules with each module having a gain

of 12 to 13 dB.

The paramp modules consist of three circulators and two varactors in a balanced configuration and the pump input circuitry -- all integrated into one case. AIL developed two slightly different modules in the process of fulfilling the paramp contract. The first units were part #556498-1. Some of these units exhibited notches in the bandpass so a second design was made with a higher dielectric constant material and the stripline configuration changed. These units are Part No. 5585569-1. The units we received were:

<u>First Stage</u>	<u>Second Stage</u>
558569-1, SN 003	556498-1, SN 018
558569-1, SN 004	556498-1, SN 026
558569-1, SN 001	558569-1, SN 007

The copper brackets in the dewar which strap the paramps to the 17 K stage on the refrigerator are slotted to accept either module type.

One Gunn diode pump source is used to drive both paramp stages. Vane type attenuators in the pump waveguides are provided for adjustment of the pump power to each stage.

The temperature and supply voltages to the pump sources are regulated to reduce power output variations. The nominal output frequency of the pump sources is 26.2 GHz. Slight adjustments in frequency were made to maximize the paramp gains. In tuning up the paramps one stage is tuned off by biasing the varactors at about +3 volts. The pump power is increased and the bias voltage adjusted to obtain 8 to 10 dB gain for the other stage. Then the first stage is turned off and the second stage pump power increased and the bias adjusted. With both stages on, the bias and the pump may have to be adjusted to obtain the desired bandpass and 25 dB gain. The insertion loss of the paramps when they are off is about 4 dB. Typical bias voltages are +0.2 to +0.8 volts. Two 1N 459 diodes

were added by NRAO across the bias port to protect the varactors from transients on the bias lines.

2.3 Upconverters

The parametric upconverters were developed by AIL. The upconverter is fabricated in microstrip on an alumina dielectric. The upconverter has two ring hybrids -- one divides the pump power and the other combines the output signal from the two varactors. An output pump rejection filter is included in the upconverter case. A detailed description of the upconverters was prepared by AIL and is entitled "Cryogenically Cooled L/C Band Parametric Upconverters".

A separate oscillator is provided to pump each upconverter. The oscillators have a voltage controlled attenuator incorporated in the output. The pump power is leveled using a coupler and detector to sense the power level.

Tuning of the upconverter is accomplished by adjusting the bias and the pump power for the best bandpass and/or input return loss. The upconverter current should be kept negative as the noise temperature increases when the current is positive. The upconverter settings are repeatable and should be resettable once the optimum tuning points are established.

2.4 Diode Switch

The diode switch was developed by George Behrens at NRAO. The switch is constructed in stripline and uses eight PIN diodes to perform the switching functions. The diodes are in shunt with the stripline and are positioned a quarter wavelength from the junctions. This switch is configured to act as a transfer switch to permit feed switching at 6 cm. It also has a cold load for feed/load switching and diodes which route the upconverter output signals to the paramp inputs. A detailed report on the design and testing of this switch is "Cryogenically-Cooled C-Band PIN Diode Switch" by George H. Behrens, Jr., Electronics Division Internal Report No. 181.

The diode switch requires 150 milliamps per diode to minimize the attenuation when the switch is cold. However, the diodes could be damaged if subjected to this current at room temperature. The diode switch supply should be turned off until the system is cold.

2.5 RF and IF Components

The 4.5 to 5.0 GHz output signals from the dewar are amplified in low noise GAS FET amplifiers as shown in Figure 2. The noise figure of this amplifier is less than 3 dB and the gain is 30 dB. A 6 dB pad between the amplifier output and the 4.5 to 5.0 GHz bandpass filter smooths the frequency response by presenting a better match to the amplifier output. Isolators are used on the input and output of the double balanced mixers to reduce mismatch ripples in the bandpass. The mixers require a minimum of 10 mW local oscillator drive which is supplied by the 3.24 to 3.74 GHz phase locked oscillator.

The outputs from the mixer are amplified in the Locus Model RF-814A 30 dB gain amplifiers and sent to the switched filter matrix. The switches are the single-pole six-position type. The filters have a center frequency of 1.26 GHz with bandwidths of 500, 200, 100, 50 and 25 MHz. Attenuators have been added to the filters to give approximately constant total power as the bandwidth is changed.

The signal is then split in a power divider. The part of the signal used as the continuum output of the receiver passes through a 0 to 10 dB variable attenuator which sets the nominal level to the total power detector. It is then amplified in another Locus RF-814A amplifier. Part of the signal is sampled through the 10 dB coupler, detected and amplified to provide a total power level for display on the analog monitor meter. An output signal at -25 dBm nominal level is available to drive the NAIC detector.

The other part of the signal is converted to 260 MHz center frequency by mixing with a fixed frequency 1 GHz signal, filtered in a 100 MHz bandwidth filter, and amplified in the TRM AD133 VHF amplifier. This output is at a nominal level of -27 dBm, with a maximum of 100 MHz bandwidth centered at 260 MHz. This signal is used for spectral line observations.

3.0 Receiver Control and Monitor

The control system is designed to provide local control of all receiver tuning adjustments and both remote and local control of selected functions. The upconverter tuning, diode switch mode and IF bandwidth can be selected remotely. The monitoring part of the system features a display panel with LED indicating when critical functions exceed preset limits. An analog monitor and multiplexer provide for monitoring up to 48 analog functions as shown in Figure 3.

The receiver control and monitor system consists of the paramp and upconverter controls, switched filter and diode switch controls, the analog monitor system, and the two-way digital link. These components are mounted on cards in the Control and Monitor drawer and the Remote Control and Monitor drawer.

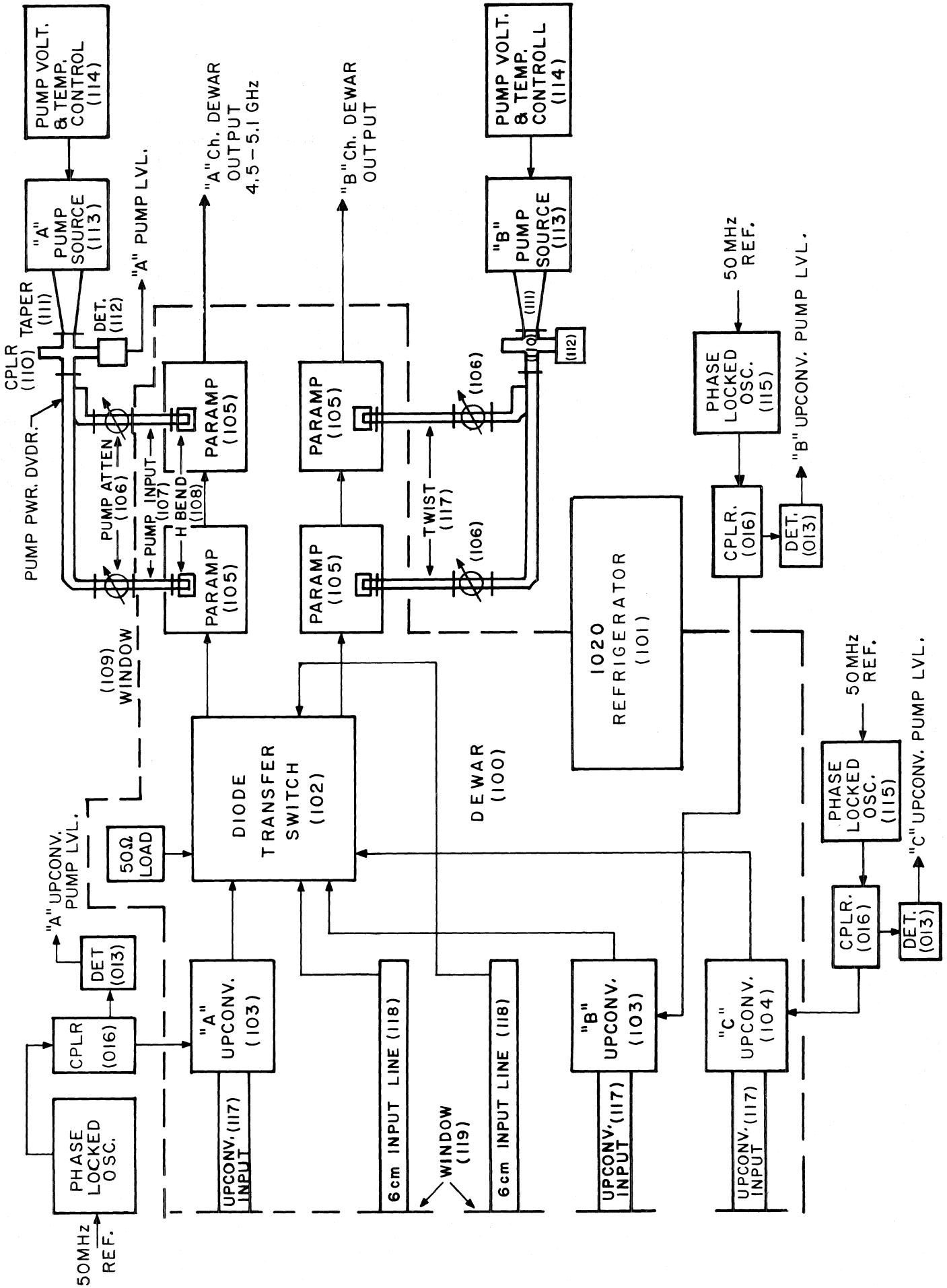

FIG. 1 NAIC RECEIVER DEWAR COMPONENTS

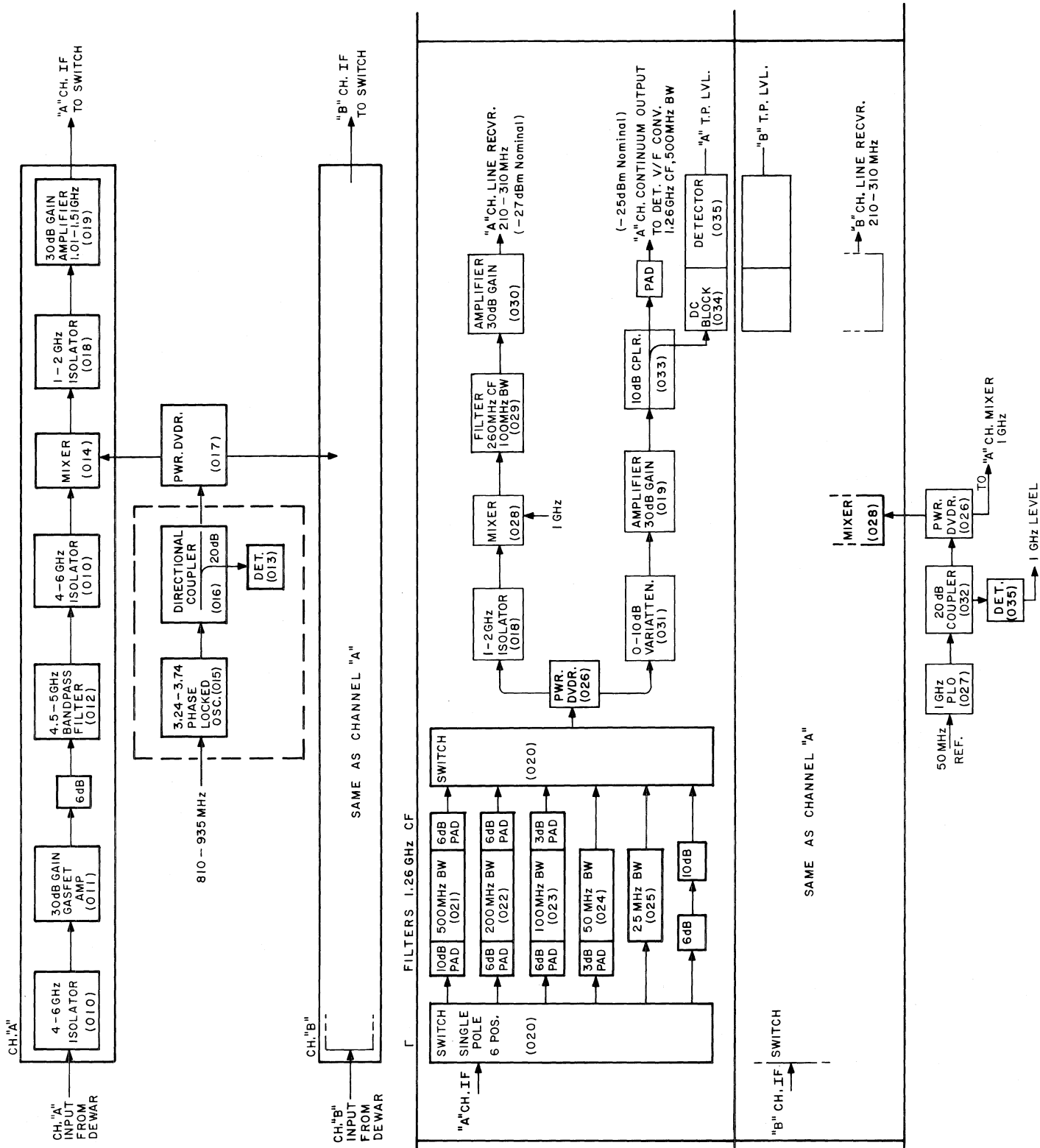

FIG. 2 NAIC RECEIVER RF & IF COMPONENTS

TABLE 1
NAIC RECEIVER PARTS

Part No.	Qty.	Description	Manufacturer	Model No.	Specifications
(010)	4	Isolator	Applied Eng. Consultants		4.4-5.1 GHz, 20 dB Isolation, 0.5 dB Insertion Loss, 1.3:1 VSWR
(011)	2	Amplifier	Avantek	SD6-0685M	4.3-5.2 GHz, 30 dB Gain, +5 dBm 1 dB PT
(012)	2	Filters	UTE Microwave	FCF-420-0	4.5-5.0 GHz BW, 0.5 dB Insertion Loss
(013)	3	Detectors	Aertech	DOM204B	2-4 GHz
(014)	2	Mixers	Aertech	MX 7000	4.5-5.1 GHz RF; 3.24-3.74 GHz LO; 1.26 GHz IF
(015)	1	Phase Locked Oscillator	Solid State Technology	SSX-0560B	810-935 MHz Input (at 6 dBm); 3.24-3.74 GHz Output (at +16 dBm)
(016)	1	Directional Coupler	Merrimac	C2M-20-3G	20 dB Directional Coupler, 2-4 GHz
(017)	1	Power Divider	Merrimac	PDM-22-3.0G	3 dB Power Divider, 2-4 GHz
(018)	4	Isolators	Applied Eng. Consultants		1.0 to 1.6 GHz, 20 dB Isolation, 0.5 dB Insertion Loss, 1.3:1 VSWR
(019)	4	Amplifiers	Locus	RF814A	1.01 to 1.51 GHz Amplifier, 30 dB Gain
(020)	4	Switch	Alpha	MT 3886-A-P3-N	1-2 GHz Switch, 40 dB Isolation
(021)	2	Filter	Lark Engineering	SF1260-500-6AA	500 MHz BW, 1.260 GHz Center Frequency
(022)	2	Filter	Lark Engineering	SF1260-200-6AA	200 MHz BW, 1.260 GHz Center Frequency
(023)	2	Filter	Lark Engineering	SF1260-100-6AA	100 MHz BW, 1.260 GHz Center Frequency
(024)	2	Filter	Lark Engineering	SF1260-50-5AA	50 MHz BW, 1.260 GHz Center Frequency
(025)	2	Filter	Lark Engineering	SF1260-25-5AA	25 MHz BW, 1.260 GHz Center Frequency
(026)	3	Power Divider	Merrimac	PDM-22-1.5G	1-2 GHz, 3 dB Power Divider
(027)	1	Phase Locked Oscillator	Solid State Technology	SSX-0101 (LAA)	1 GHz PLO
(028)	2	Mixers	Aertech	MX 2000	1.0 to 1.51 GHz RF; 1 GHz LO; 210-210 MHz IF
(029)	2	Filter	Lark Engineering	HQ-260-100-6AA	210-310 MHz BW, 30 dB Gain
(030)	2	Amplifier	TRM	AD-133	0-10 dB, 1 dB Step Attenuator
(031)	2	Attenuator	Texscan	MA-50	20 dB, 1-2 GHz
(032)	1	Directional Coupler	Merrimac	C2M-20-1.5G	10 dB, 1-2 GHz
(033)	2	Directional Coupler	Merrimac	C2M-10-1.5G	Inner and Outer DC Block
(034)	2	DC Block	Omni Spectra	OSM 203536	1-2 GHz
(035)	3	Detectors	Aertech	DOM 102B	-
(100)	1	Dewar	NRAO	Dwg. M2.586-6 Sheets 1, 3 & 4 and M2.602-1	-
(101)	1	Refrigerator	Cryogenic Technology, Inc.	Stock #E3761132 Model 1020	-
(102)	1	Diode Transfer Switch	NRAO	Dwg. M2.586-7	-
(103)	2	Upconverter	AIL	NRAO Spec A13150N2, Rev. A	1.35-1.73 GHz Upconverter
(104)	1	Upconverter	AIL	NRAO Spec A2584N1, Rev. A	1.0-1.45 GHz Upconverter
(105)	4	Params	AIL	NRAO Spec A13140N1, Rev. D	4.75 GHz Parametric Amplifier
(106)	4	Variable Attenuator	Atlantic Microwave	AT 281	26.1 GHz, 0-20 dB
(107)	-	Pump Input Lines	NRAO	Dwg. M2.586-2	-
(108)	4	H-Plane Bend	Atlantic Microwave	HB 280M4	-
(109)	2	WG Window	-	-	-
(110)	2	Coupler	Atlantic Microwave	CG 280IM2	20 dB Coupler, 26.1 GHz
(111)	2	WG Taper	Aircom Microwave	195(B)00	-
(112)	2	Detector	Atlantic Microwave	DT283	26.1 GHz WG Detector
(113)	2	Gunn Oscillators	Varian	VSK-9004TG	100 mW at 26.1 GHz
(114)	2	Pump Voltage and Temperature Controls	NRAO	-	VIA Technical Report #10
(115)	2	Phase Locked Oscillator	Solid State Technology	SSX-0554(BLIA)	3200 MHz Output, 50 MHz Input; RFQ #GB-065
(116)	1	Phase Locked Oscillator	Solid State Technology	SSX-0554(BLIA)	3500 MHz Output, 50 MHz Input; RFQ #GB-065
(117)	3	Upconverter Input Line	Maury Microwave	-	NRAO Dwg. M2.586-1, Rev. 3
(118)	2	Paramp Input Line	Maury Microwave	-	NRAO Dwg. M2.586-3, Rev. 2
(119)	2	WG Window	-	-	VSWR 1.1:1 over 4.5-5.0 GHz

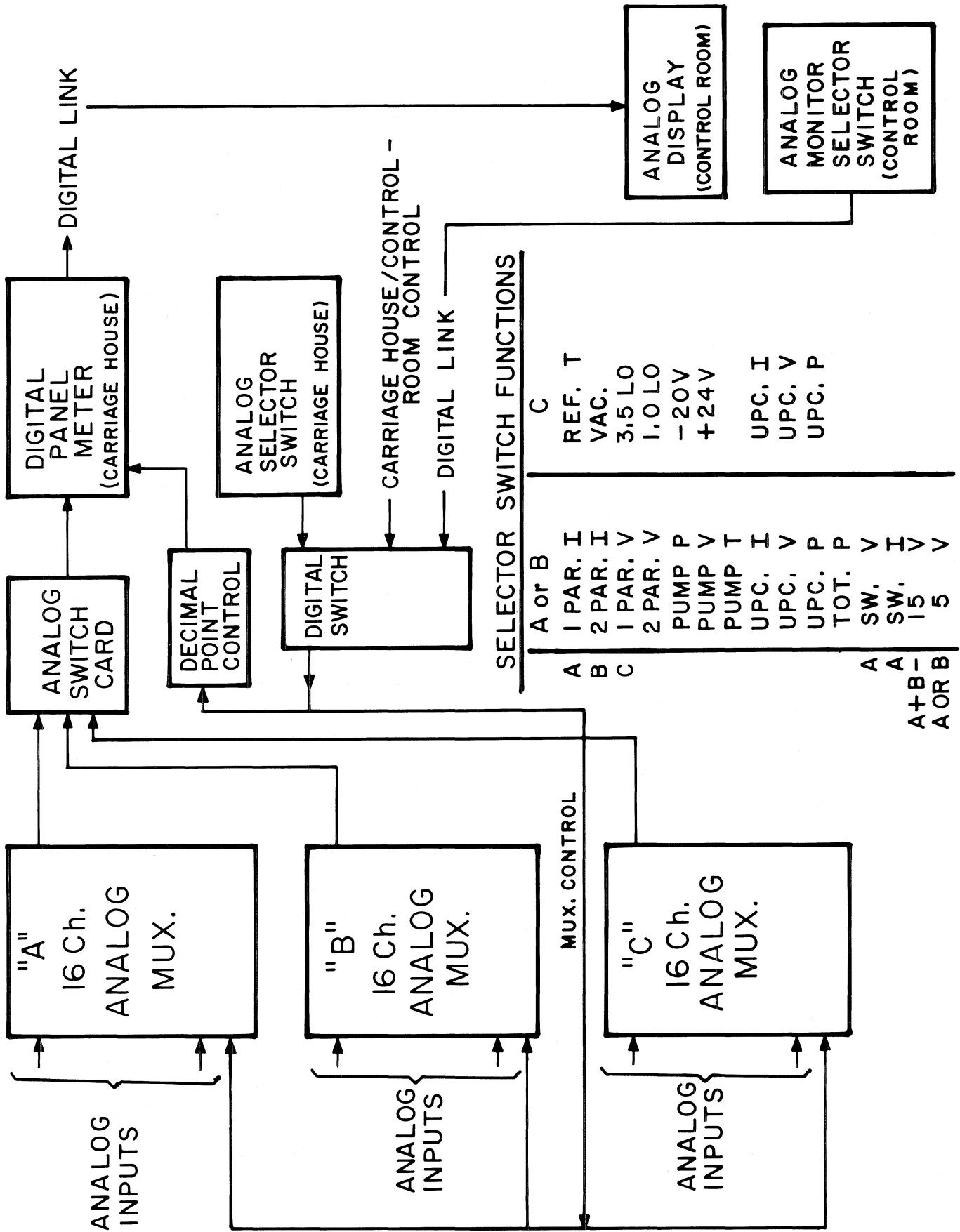

FIG. 3 NAIC REC. ANALOG MONITOR BLOCK DIAGRAM