

NATIONAL RADIO ASTRONOMY OBSERVATORY
GREEN BANK, WEST VIRGINIA

ELECTRONICS DIVISION INTERNAL REPORT No. 148

CASSEGRAIN TEMPERATURE CONTROLLER

GEORGE BEHRENS AND JOHN LIEBENROOD

NOVEMBER 1974

NUMBER OF COPIES: 150

CASSEGRAIN TEMPERATURE CONTROLLER^o

G. Behrens and J. Liebenrood

TABLE OF CONTENTS

	<u>Page</u>
<u>Introduction</u>	1
<u>System Description</u>	2
<u>Operating Instructions</u>	3
Cables and Refrigerant Lines	3
Circuit Breakers	4
Indicator Lights	4
Controls	5
Meters	5
Winter Operation	6
<u>Temperature Control System Details</u>	6
SCR Proportional Controller	7
Temperature Control Circuit	7
Heater Current Meter Circuit	9
High Temperature Alert Circuit	9
<u>Wiring Diagrams</u>	10
<u>Liquid Chiller and Air Handler Details</u>	11

LIST OF FIGURES

Figure 1 — Temperature Control System Block Diagram	1
Figure 2 — 140' Telescope Vertex Cabin Air-Condition System	2
Figure 3 — Air-Condition System Intercabling Diagram	3
Figure 4 — Temperature Controller Printed Circuit Board Schematics	8
Figure 5 — Temperature Controller Wiring Diagram	10
Figure 6 — Air Handler Wiring Diagram	10
Figure 7 — Liquid Chiller Wiring Diagram	10

CASSEGRAIN AIR CONDITIONING SYSTEM

G. Behrens and J. Liebenrood

Introduction

The following is a brief description of the air conditioning system used for temperature stabilizing the 140-ft telescope vertex cabin. The system uses an Ellis and Watts Company Model LCAH-23 chilled water system and a proportionally controlled heater. The system has been designed to maintain the cabin temperature at $22^{\circ}\text{C} \pm 1^{\circ}\text{C}$ over an ambient temperature range from -30°C to $+45^{\circ}\text{C}$ (-22°F to $+113^{\circ}\text{F}$). The system has also been designed to maintain its 22°C set point with a cabin internal heat load variance of 0-3600 watts. Using the temperature control panel located in the control room, the operator may adjust the set point from 20 - 30°C , monitor the temperature in the cabin and turn the system on or off. The major components of the system are as shown in Figure 1.

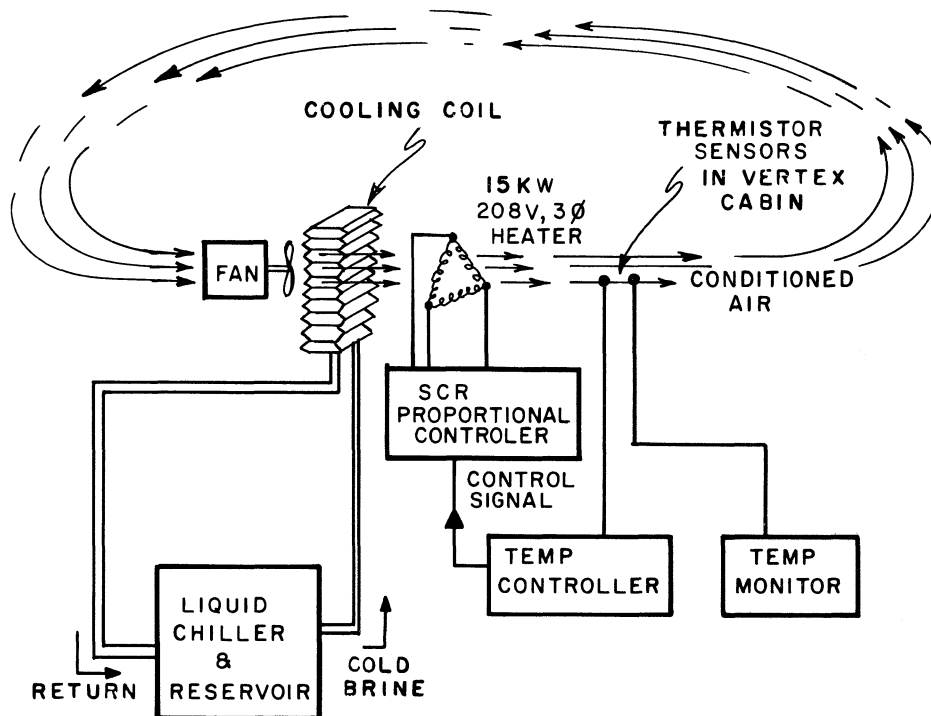

TEMP. CONTROL SYSTEM
BLOCK DIAGRAM

FIG. 1

General Description

The gimbal-mounted liquid chiller is located on the yoke of the telescope and connected to the air handler with supply and return coolant line and electrical cables. The liquid chiller cools the brine solution (50% ethylene glycol/50% water) and pumps it to the air handler unit located on the outside of the vertex cabin (see Figure 2). The air handler houses the cooling coil, the 15 kW heater, the fan and the RFI-suppressed SCR proportional controller. Air from the vertex cabin is drawn into the air handler via duct work by the circulating fan and passed across the cooling coil where the heat is transferred to the cold brine solution. Before re-entering the cabin, the air is re-heated by the proportionally-controlled 15 kW heater to the right temperature to maintain a stable temperature in the cabin.

Remote operation and monitoring of the system is accomplished from the temperature control panel and temperature monitor panel located in the control room temperature control rack. Remote operation of the Cassegrain feed defroster is also from the temperature control panel.

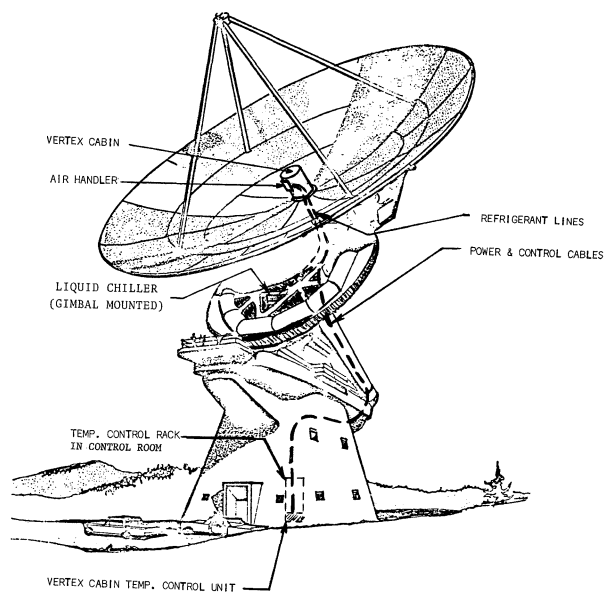

FIGURE 2

NATIONAL RADIO ASTRONOMY OBSERVATORY	
TITLE: 140' TELESCOPE VERTEX CABIN - AIR CONDI- TION SYSTEM - Pictorial.	
DSGN. BY: BENRENS	DATE: 3-22-73
APPD. BY:	DR. BY: T.M.
DWG. NO. M0-1001	

Operating Instructions

Cables and Refrigerant Lines

Before attempting operation insure supply and return refrigerant lines are connected between the liquid chiller and the air handler. Similarly, insure all cables are connected as shown in Figure 3.

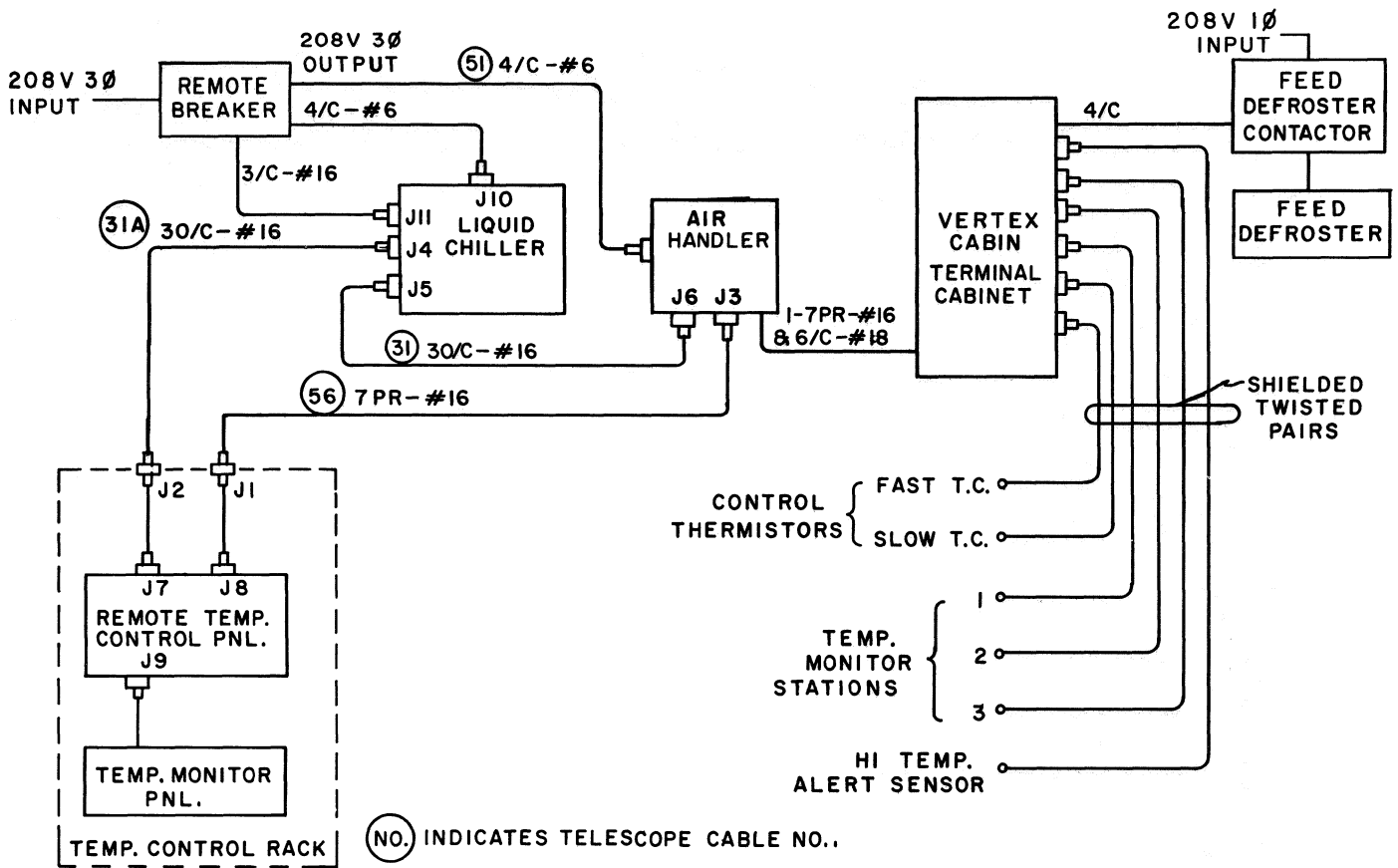

AIR CONDITION SYSTEM INTERCABLING DIAGRAM

FIG. 3

Circuit Breakers

There are five breakers which must be operated before the system becomes operational. Four of these breakers are manually operated and are located at the liquid chiller and air handler -- two at each station. One of the breakers at the chiller protects the chiller itself and the other protects the chiller crankcase heater. The two breakers at the air handler are for the circulating blower and the 15 kW heater. The fifth breaker is a remotely-operated motorized breaker which makes and breaks power to the entire system. This breaker is operated from the main power switch located on the temperature control panel in the control room. Under normal circumstances, all of the manual breakers are left in the ON position and the system can be turned on or off by simply using the power switch on the temperature control panel.

Indicator Lights

There are several indicator lights on the temperature control panel to indicate whether power is available at the various components in the system. The function of each is as explained below.

Power light: This light indicates when main power to system is connected. When turning the system on or off from the main power switch, there will be a momentary delay before the light goes on or off because of the motorized action of the main breaker.

Heater light,
Blower light,
Chiller light: These lights indicate when power is connected to the respective component. If any of these lights are out when the main power light is on, it indicates that either the breaker to that component is off or has been tripped due to an overload.

Hi temp alert light: This light will operate along with an audio alarm if the temperature in the cabin rises above a level determined by the hi temperature alert circuit. Details on this circuit are given below.

Defroster light: This light will illuminate when power is applied to the feed defroster located on the roof of the vertex cabin. The defroster blows warm air across the feeds on the cabin roof to prevent ice from forming. The defroster is operated from a switch on the temperature control panel.

Controls

Temperature adjust: The cabin temperature may be adjusted within the range of 20°-30°C with this adjustment.

Thermal T.C.: This switch allows the operator to select either a fast or slow thermal time constant for the control system. In the fast mode the system is controlled by a thermistor located in the supply air duct of the air handler. In the slow mode the control thermistor is located at the receiver rack. From experimentation it was found that using the fast T.C. improves the temperature stability at the receiver rack by reducing the degree of temperature cycling at the receiver. However, if it is desirable to change the temperature of the cabin by several degrees, it is advantageous to use the slow T.C. until the desired temperature is achieved and then switch back to fast T.C. to insure good stability. If a large temperature adjustment is made in the fast mode, it will take much longer for the temperature at the receiver to reach the desired level.

Meters

The three meters on the temperature control panel along with the temperature monitor meter on the temperature monitor panel give the operator information as to how well the temperature control system is working. The

temperature within the vertex cabin is read out at the temperature monitor panel which is mounted directly below the temperature control panel.

Error meter: The error meter indicates the difference between the set point, the temperature set by temperature adjust control, and the actual temperature at the controlling thermistor.

Control current meter: This meter indicates the amount of the temperature controller output current which drives the SCR proportional controller at the air handler.

Heater current: This meter indicates the percent of full load current drawn by the 15 kW, 3-phase heaters. A phase selector switch permits monitoring of each phase separately.

Winter Operation

To conserve energy during cold weather conditions, it may be possible to operate the system with the liquid chiller off providing the heat load in the cabin is not too great. To do this simply move the chiller breaker to the off position; however, be certain the chiller crankcase heater breaker is turned on. This will prevent liquid refrigerant from accumulating in the compressor crankcase which could cause damage upon starting.

When restarting the compressor after an extended shutdown period, move the liquid chiller breaker from on to off quickly several times until the compressor starts quickly.

Temperature Control System Details

The system functions as described above in the general description section.

SCR Proportional Controller

The zero-fired, RFI-suppressed SCR proportional controller is located in the air handler assembly and controls the 15 kW, 3-phase heaters. This component was manufactured by Payne Engineering and detailed information on the device may be found in the Ellis-Watts LCAH-3 air-conditioning manual.

Temperature Control Circuit

The temperature control circuit shown in Figure 4 provides the necessary control signal current for the SCR controller. This circuit is located on a printed circuit board mounted in the temperature controller in the control room. The circuit amplifies the output of a bridge circuit formed by one of the control thermistors and the temperature adjust pot VR-1, and sends this signal up a telescope cable to drive the SCR controller. The two control thermistors are located in the vertex cabin; one is located in the air handler supply vent (fast T.C.) and the other is located in the receiver rack (slow T.C.). Selection of either of these control thermistors is made with the thermal T.C. switch on the temperature control panel.

Temperature error meter, M_1 , measures the error between the set point and the temperature of the controlling thermistor. Control current meter, M_2 , indicates the amount of current driving the SCR proportional controller. Both of these meters are located on front of the temperature controller.

See the next page for Figure 4.

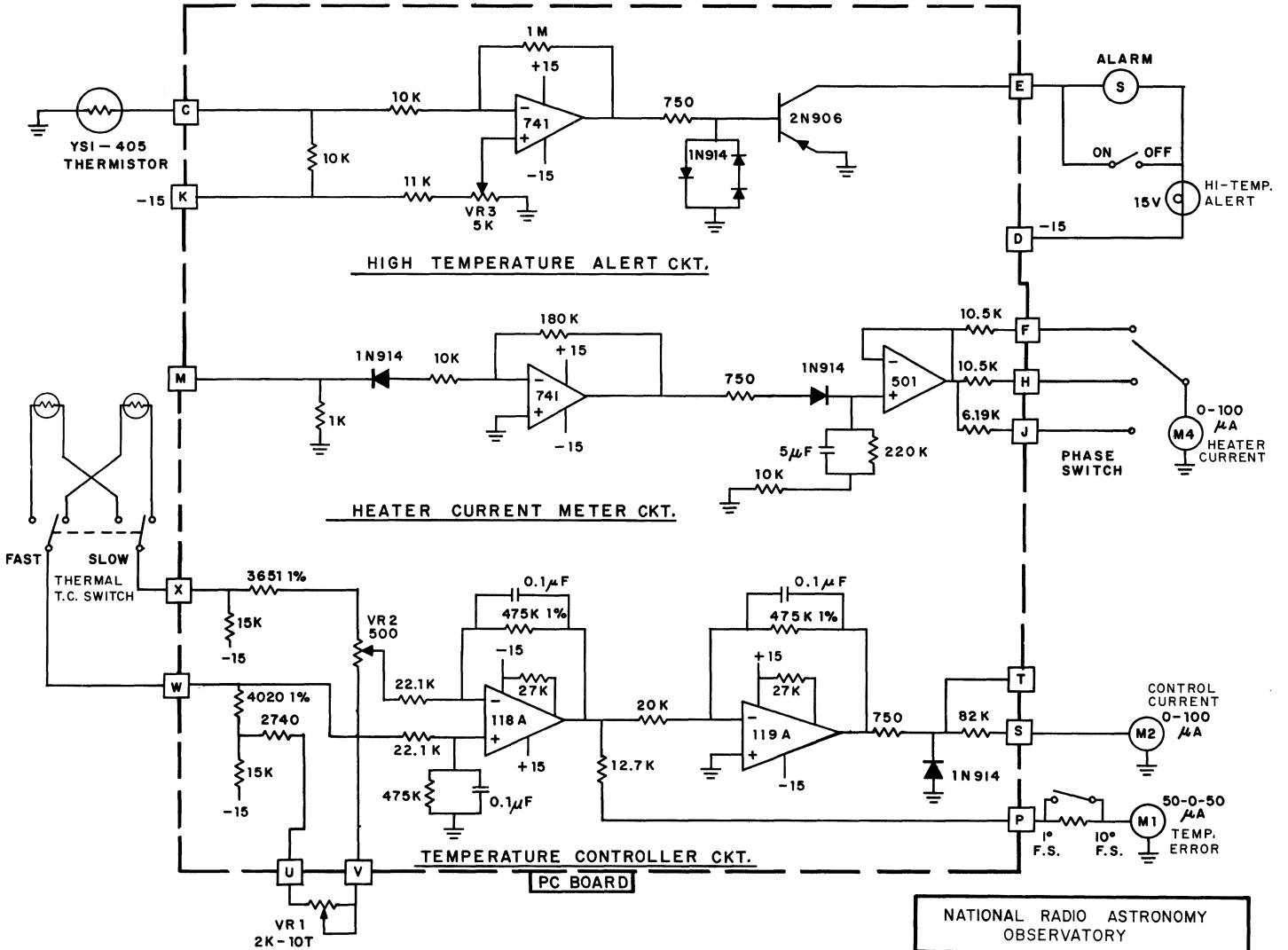

FIG. 4

NATIONAL RADIO ASTRONOMY OBSERVATORY	
TITLE VERTEX CABIN TEMP. CONTROLLER PRINTED CIRCUIT BOARD SCHEMATIC	
DESIGN BY J. LIEBENROOD	DATE 9 / 74
APPROVED BY <i>[Signature]</i>	DRAWN BY J. L. / T. M.
No. _____	DWG No. S 2-493-2
DATE _____	
REVISIONS _____	
BY _____	

Heater Current Meter Circuit

The output of the 15 kW heater is monitored by three current transformers located in the air handler. Each current transformer monitors the current in one of the three legs of the 3-phase heater. The output from the transformers is sent down the telescope cabling, amplified, filtered, and displayed by the heater current meter circuit shown in Figure 4. The meter has been calibrated to read percent of full load current. The phase switch allows the operator to individually monitor the three phases of the heater.

High Temperature Alert Circuit

The high temperature alert circuit shown in Figure 4 has been incorporated in the system to alert the operator in case the temperature in the cabin rises above a certain temperature (trip temperature) which is determined by the circuit. The trip temperature is adjustable and is normally set at 35°C. In the event of an equipment failure or fire which might cause the cabin temperature to exceed the trip temperature, an audio alarm and light will alert the operator.

Wiring Diagrams

Wiring diagrams for the entire system are shown in the following figures (5, 6, and 7):

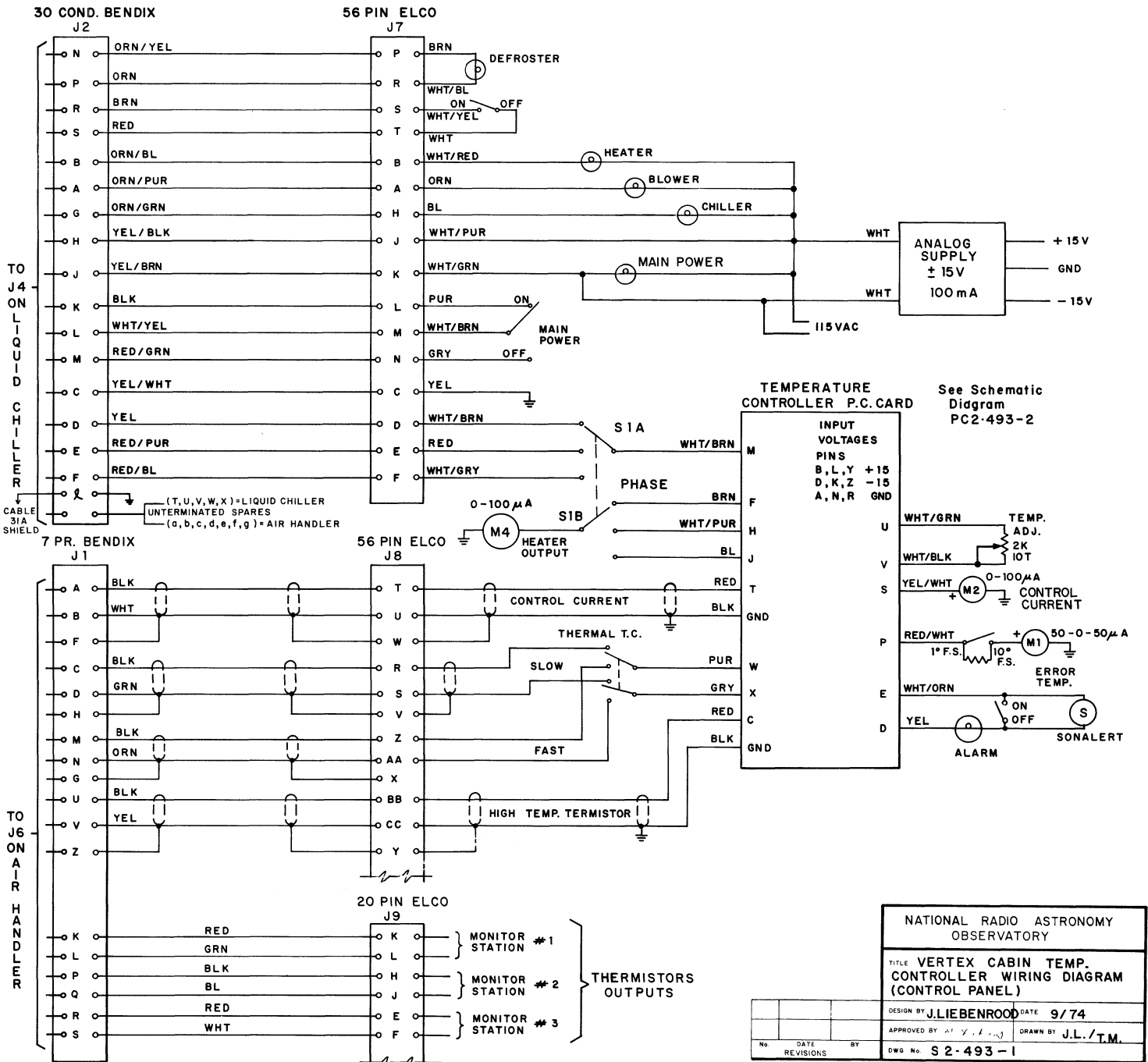
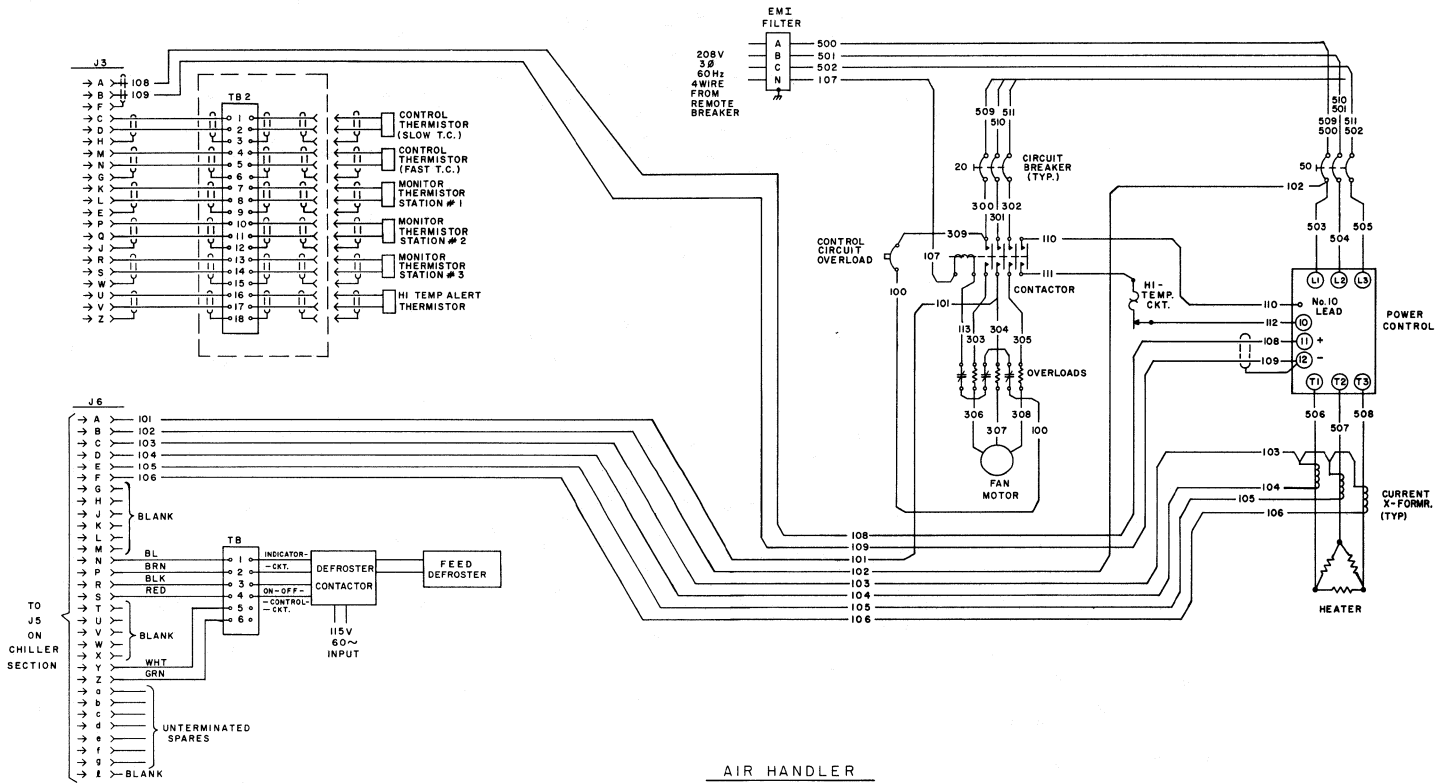

FIG. 5

NATIONAL RADIO ASTRONOMY OBSERVATORY	
TITLE VERTEX CABIN TEMP. CONTROLLER WIRING DIAGRAM (CONTROL PANEL)	
DESIGN BY J. LIEBENROOD	DATE 9/74
APPROVED BY [Signature]	DRAWN BY J.L./T.M.
No. _____	REVISIONS _____
DWG. No. S 2-493-1	



AIR HANDLER

FIG. 6

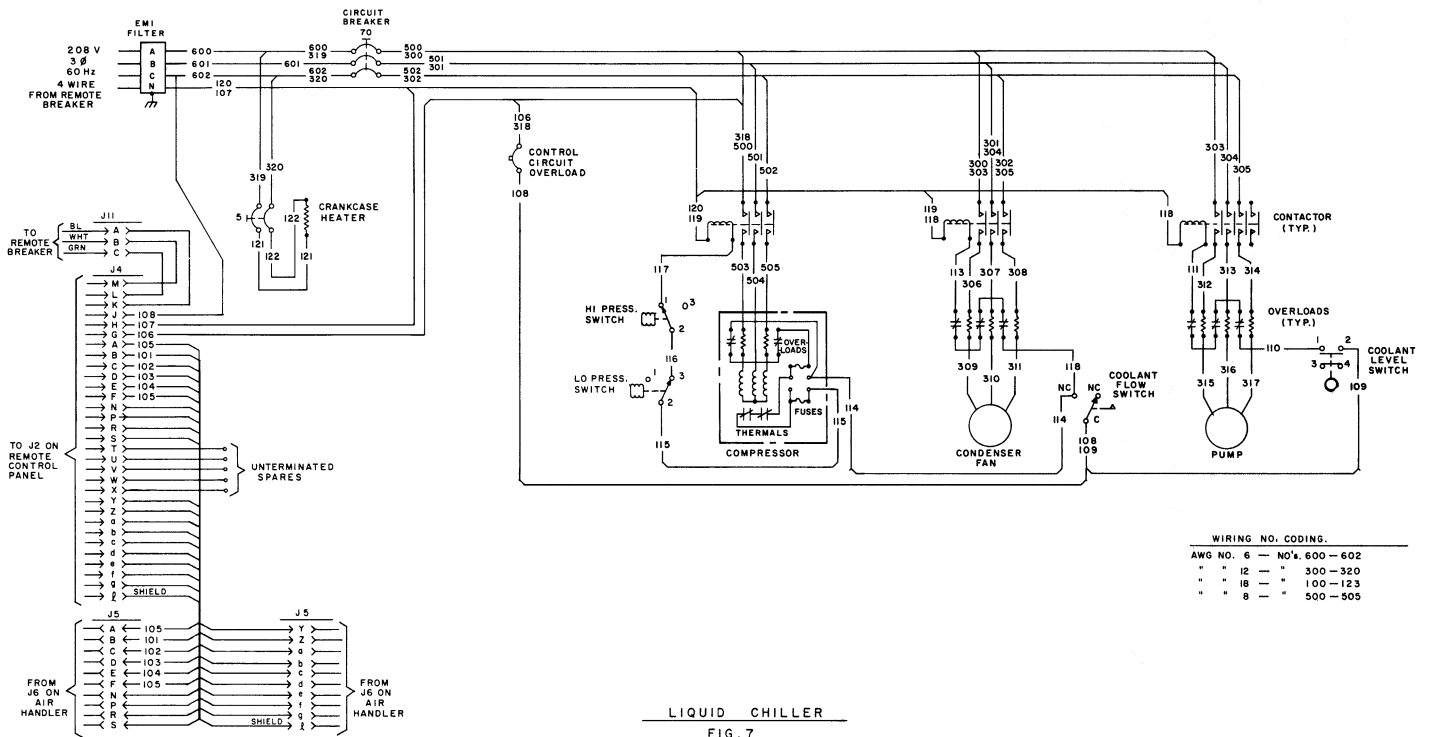

LIQUID CHILLER

FIG. 7

WIRING NO. CODING.

AWG NO. 6	-	NO'S. 600 - 602
" 12	"	300 - 320
" 18	"	100 - 123
" 8	"	500 - 505

Liquid Chiller and Air Handler Details

Below is tabulated the manufacturer's data on the chiller and air handler. For further details on operation and maintenance of this equipment, refer to the Ellis-Watts equipment manual on the LCAH-23 air-conditioning system.

Liquid Chiller

Cooling Capacity	27,000 BTU/hr at 113°F air entering air cooled condenser with 38°F brine (50% ethylene glycol/50% water) supply and 51°F brine return.
Pump Capacity	5 gpm at 30 psig.
Brine Reservoir	17 gallons.
Weight	Approximately 1090 lbs dry.
Cabinet	60" wide by 30" deep by 60" high.
Power	Main : 208 V, 3 phase, 60 Hz, 4 Wire. Control: 120 V, 1 phase, 60 Hz.

Air Handler

Cooling Capacity	18,000 BTU/hr at 22° ± 5°C control point.
Heating Capacity	51,225 BTU/hr (minimum) 15 kW.
Circulated Air	1000 cfm.
Weight	Approximately 355 lbs dry.
Cabinet	36" wide by 18" deep by 72" high.
Power	Main : 208 V, 3 phase, 60 Hz, 4 Wire. Control: 120 V, 1 phase, 60 Hz.