

NATIONAL RADIO ASTRONOMY OBSERVATORY
Green Bank, West Virginia

Electronics Division Internal Report No. 142

AUTOMATIC NOISE FIGURE METER FRONT-END

Richard L. Fleming

MAY 1974

NUMBER OF COPIES: 150

AUTOMATIC NOISE FIGURE METER FRONT-END

Richard L. Fleming

TABLE OF CONTENTS

	<u>Page</u>
1.0 Introduction	1
2.0 Description of Unit	1
3.0 Operation as Noise Figure Meter Front-End	2
4.0 Operation as a Receiver Back-End	3

LIST OF FIGURES

1. Noise Figure Meter Frequency Converter Block Diagram	4
2. Receiver Back-End Block Diagram	5
3. Overload Detector Schematic	6
4. 30 MHz Filter and Detector Schematic	6
5. Local Oscillator Frequency Control Schematic	6
6. Photo of Unit Front Panel	7
7. Photo of Unit Top	8
8. Photo of Unit Sides	9

AUTOMATIC NOISE FIGURE METER FRONT-END

1.0 Introduction

This report describes the construction and operation of a wide frequency range front-end for use with the AIL-75 Precision Automatic Noise Figure Indicator (PANFI). The PANFI accepts a 30 MHz input frequency with a 5 MHz bandwidth and when used with the noise source supplied will indicate noise figures automatically in one of five ranges up to 33 dB. To extend the usefulness of the PANFI, this front-end will enable noise figure measurements to be made in the frequency ranges of 0.1-0.85 GHz and 1.0-2.0 GHz.

2.0 Description of Unit

The 0.1-2.0 GHz range is covered by converting these frequencies to a 30 MHz IF to be used with the PANFI. By tuning the LO adjust control on the front panel, automatic measurements can be made through the passband of a unit under test. The LO adjust control is calibrated to read out the RF frequency where the spot (5 MHz BW) noise figure test is being made.

Another feature incorporated in the unit is essentially a broad-band receiver back-end covering the range of 10-500 MHz with a square law detector with better than 1% accuracy. The output of the detector is indicated on a 4 1/2 digit high accuracy DPM which also has an external DC input jack.

A DC offset control is available on the front panel to back out the noise temperature of the input amplifier so the DPM can read directly in °K, after calibration.

The square-law detector incorporated in the unit consists of a carefully matched detector (HP 423A) and DC amplifier, all of which is housed in a temperature controlled oven. The deviation from square law is less than 1.0 percent with typical input/output levels of -23 dBm = 1.0 volt and -13 dBm = 10 volts.

The first LO is a Yig oscillator which also has a heater built in. A 30-minute warm-up time should be allowed before using the unit due to the fact that temperature stabilization should occur in the two components just mentioned.

3.0 Operation as a Noise Figure Meter Front-End

The lower half of the unit is designed to be used as a front-end (converter) for the AIL-75 PANFI. Inputs in the frequency ranges of 100 MHz to 850 MHz and 1.0-2.0 GHz are converted to 30 MHz for use with the PANFI. The PANFI accepts a 30 MHz input with a 5 MHz bandwidth and a -60 to -10 dBm level. The front-end always produces a 30 MHz IF signal and the RF frequency that the unit is tuned to is indicated by the first LO dial. In the 100-850 MHz band, the yellow band marker light and the yellow strip on the LO dial are associated. The 1-2 GHz band (green light) and green strip on the LO dial indicates the RF frequency on the high band.

The "Peak with LO Adjust" meter is driven by a narrow (1 MHz) filter and a detector centered at 30 MHz so that there is always indication that 30 MHz is appearing at the output. This is particularly important when doing spot (5 MHz BW) noise figure measurements at a particular RF frequency.

To measure the noise figure of an amplifier, connect the amplifier output to the 0.1-2 GHz input of the frequency converter section. Connect the proper noise diode that comes with the PANFI to the amplifier input. The noise diode is driven from the back of the PANFI (with the rack panel switch set on "Diode"). Select the proper frequency band and tune the "LO Adjust" for the frequency at which a noise figure measurement is desired. If the amplifier is narrowband, it is necessary to slightly tune the "LO Adjust" for a peak in the 30 MHz output meter. This will guarantee that you are centered in the passband of the amplifier. The "LO Adjust" dial is accurate to within 15 MHz (worst case) across the 1-2 GHz

band. Connect the 30 MHz output to the IF input of the PANFI. Enough 30 MHz output is present for the PANFI if the AGC light is on. An automatic or manual noise figure can now be made using the PANFI in the normal way.

4.0 Operation as a Receiver Back-End

The top half of the unit consists of several amplifiers, variable attenuators, square law detector and a digital panel meter. The bandwidth is 10-500 MHz with switchable and vernier gain controls. The following outputs/inputs are available on the back panel: amplifier/attenuator chain output, detector RF input, detector DC output and DC input to DPM gain and zero controls. These output/input ports are normally connected together but can be separated by changing the connections on the back panel. There is also a front panel EXTERNAL VIDEO (DC) input to the DPM for 0-9.999 V DC input.

Excellent square law detector measurements can be made using the amplifier/detector/DPM chain. To be within the square law region the front panel controls should be set as follows: 0-10 dB attenuator set to 5 dB, 0-60 dB attenuator set to 20 dB, 23 dB/43 dB switch set to 43 dB, DC gain adjust set to 500, level set to 515, offset/total power switch set to total power and adjust the DPM to 1.000 volt using external padding. This would be equal to an input level of approximately -55 dBm.

Adjust the input level ± 3 dB and check the DPM for an appropriate change in voltage (2.0 V, 0.50 V). If this is within 20-30 mV (due to the change not exactly 3.00 dB), the unit is set for making good measurements.

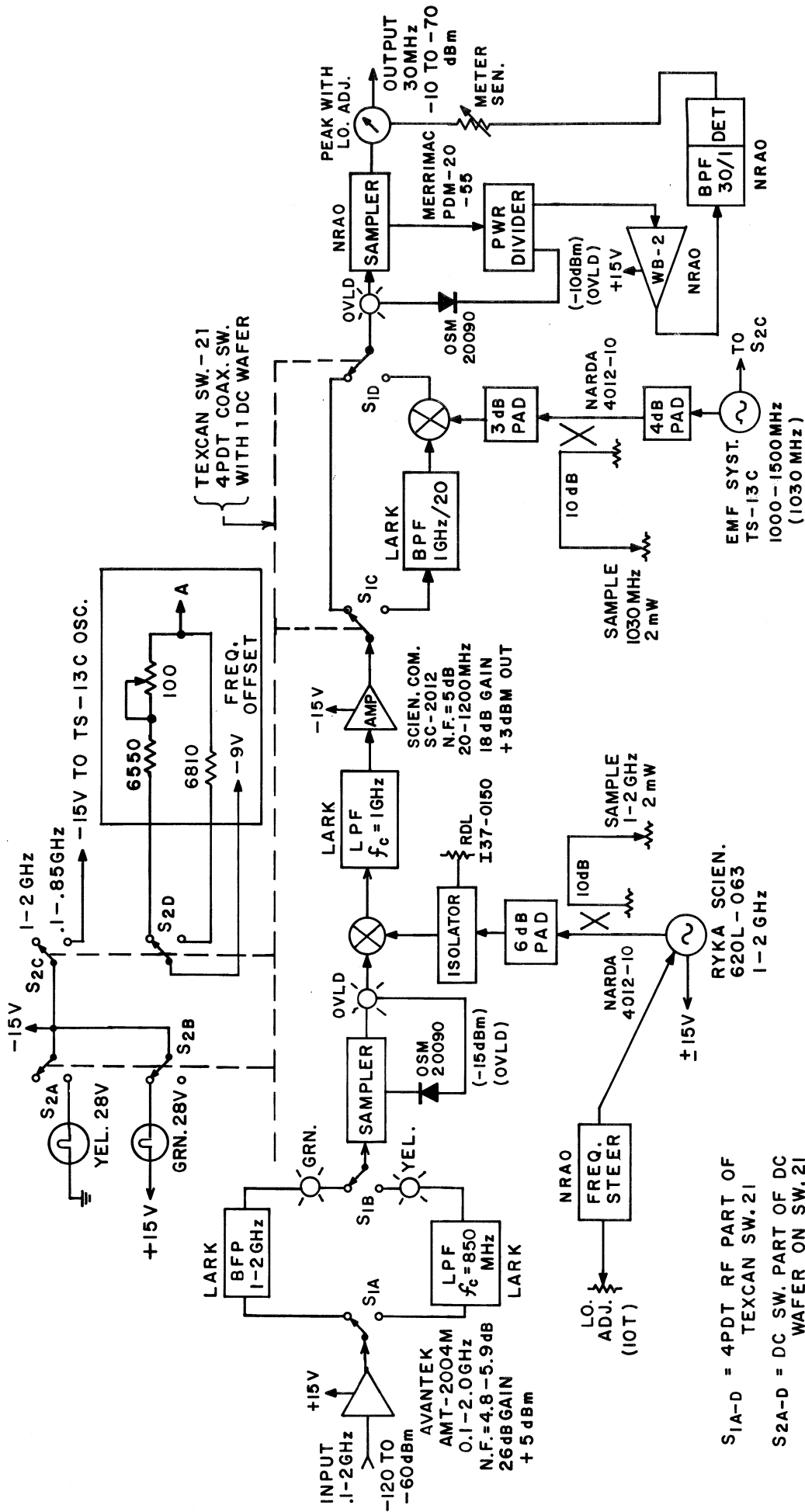

S1A-D = 4PDT RF PART OF
 TEXCAN SW.21
 S2A-D = DC SW. PART OF DC
 WAFER ON SW.21

FREQUENCY CONVERTER

0.1 - 2 GHz TO 30 MHz

FIG. 1

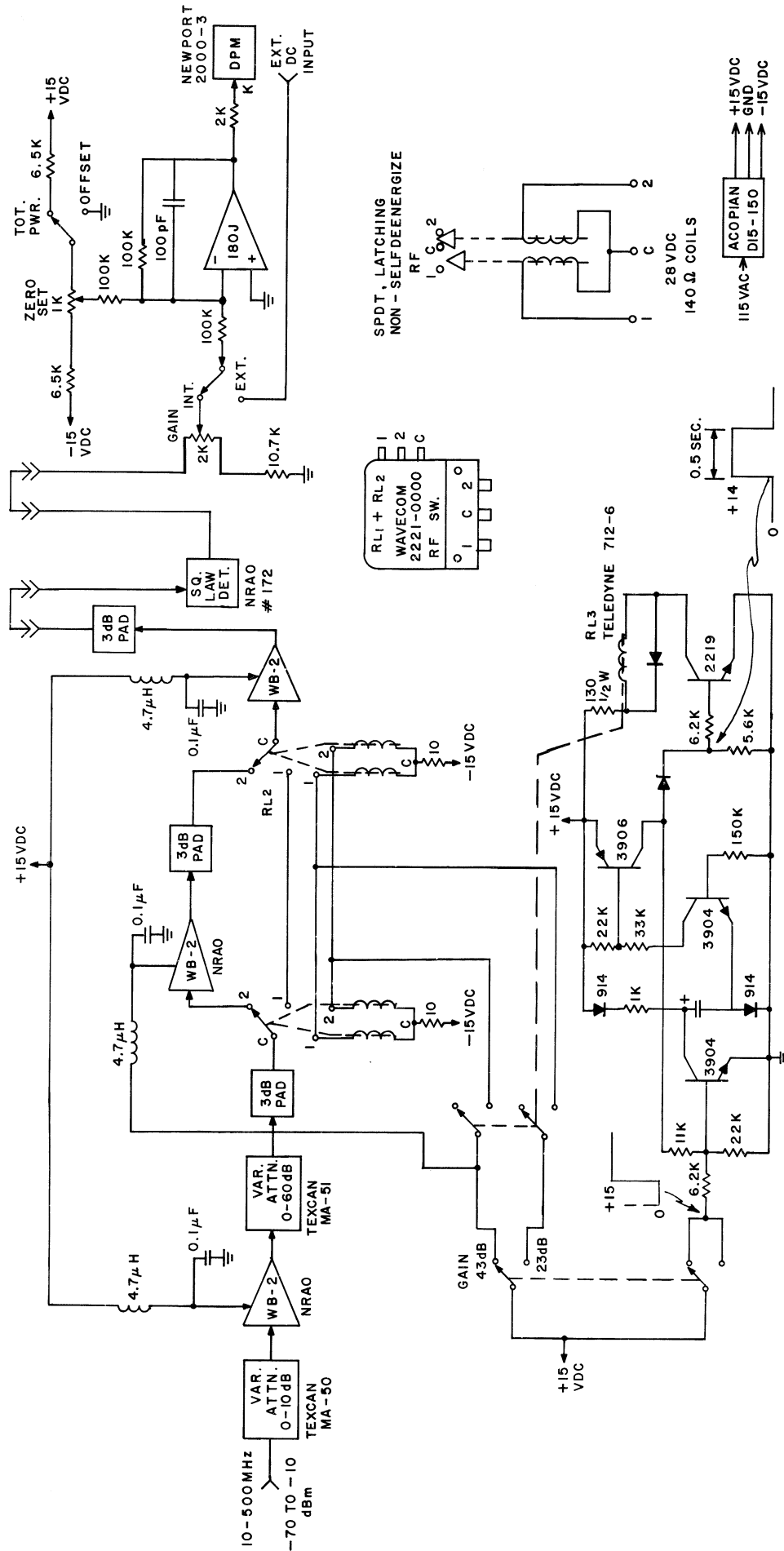

RECEIVER BACK-END
FIG. 2

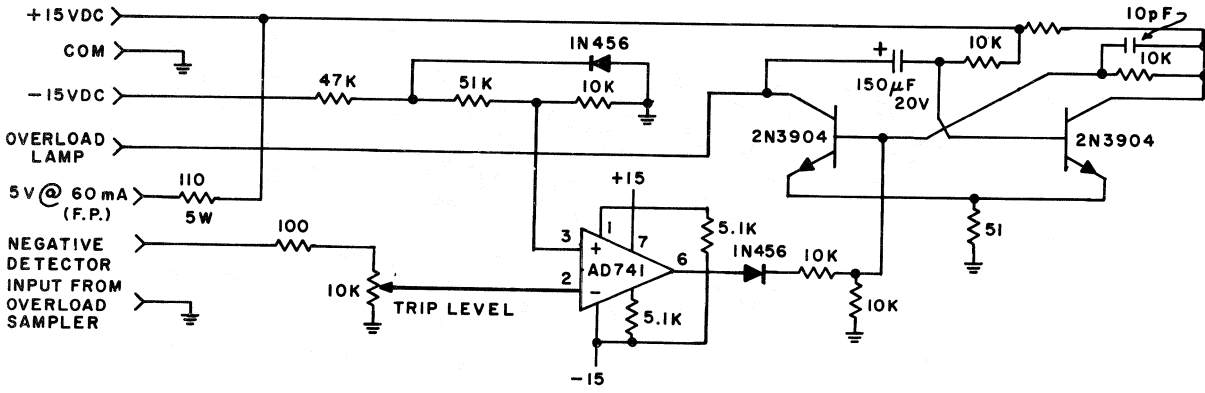

OVERLOAD DETECTOR

FIG. 3

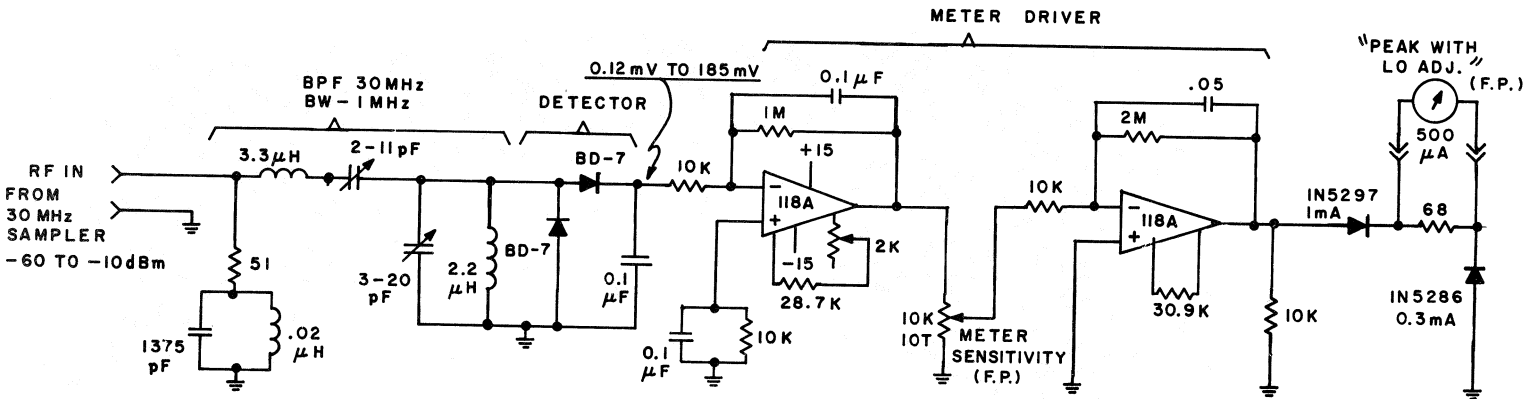

30MHz BPF / DETECTOR / METER DRIVER

FIG. 4

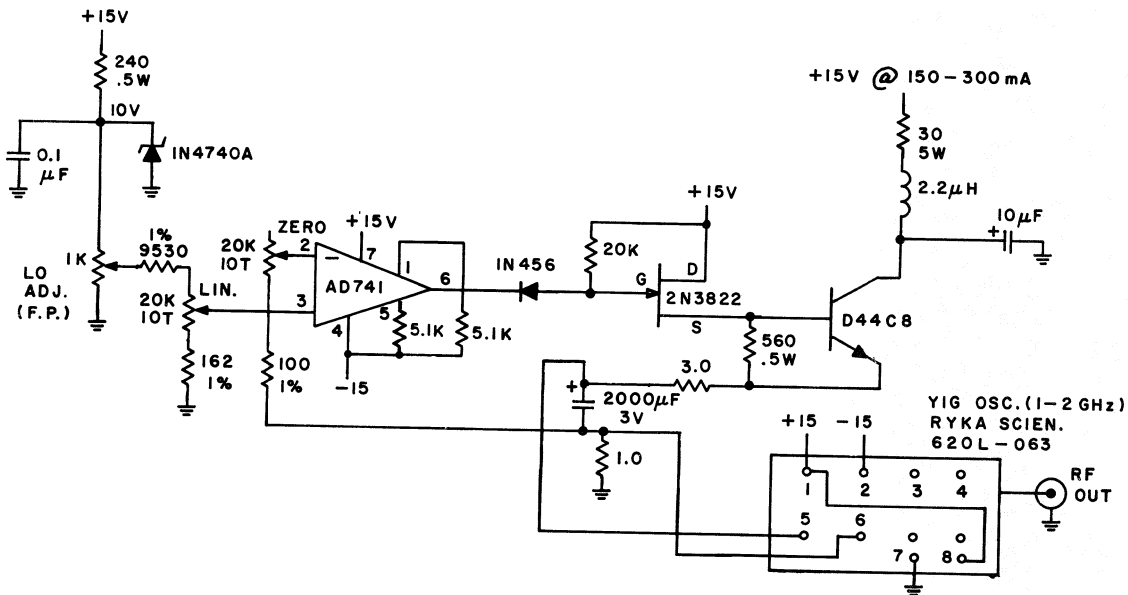

YIG OSCILLATOR FREQUENCY CONTROL

FIG. 5

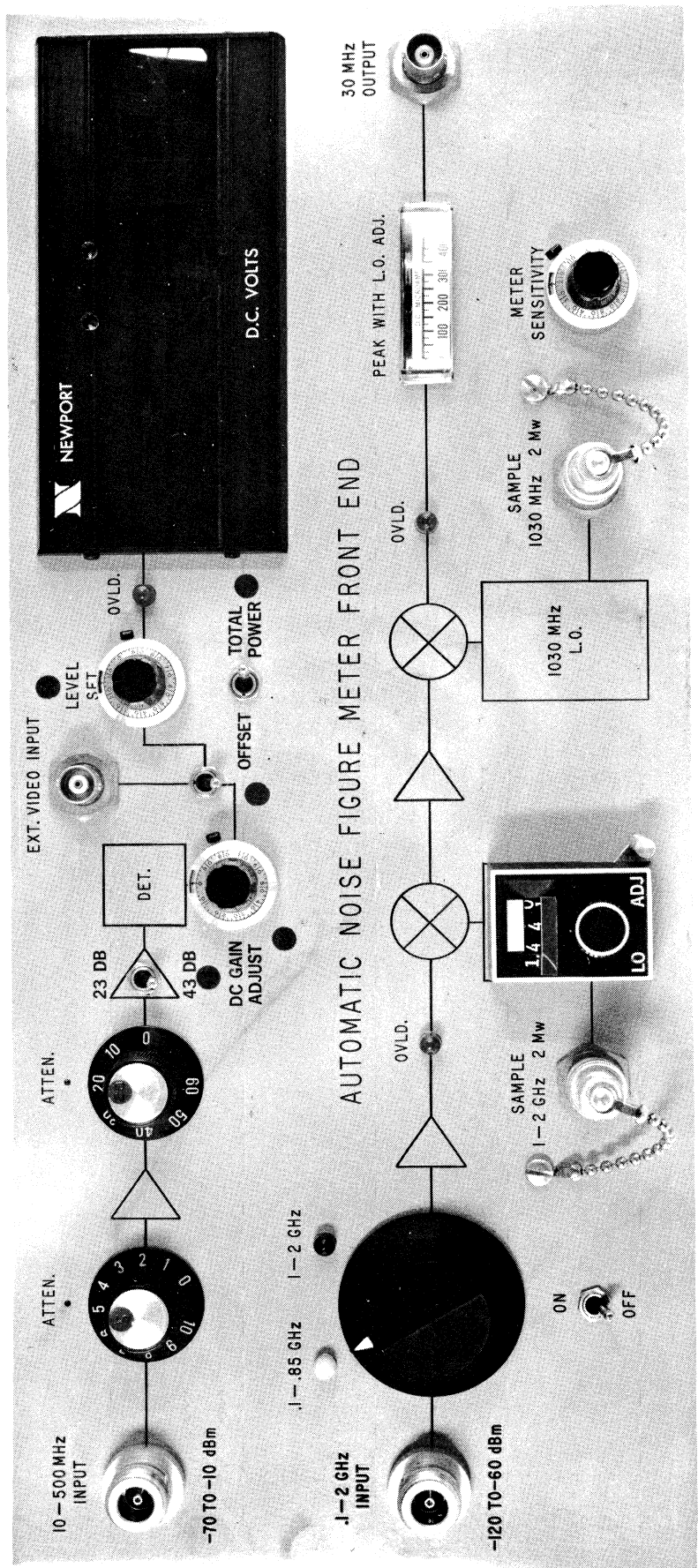

Figure 6 — Photo of Unit Front Panel

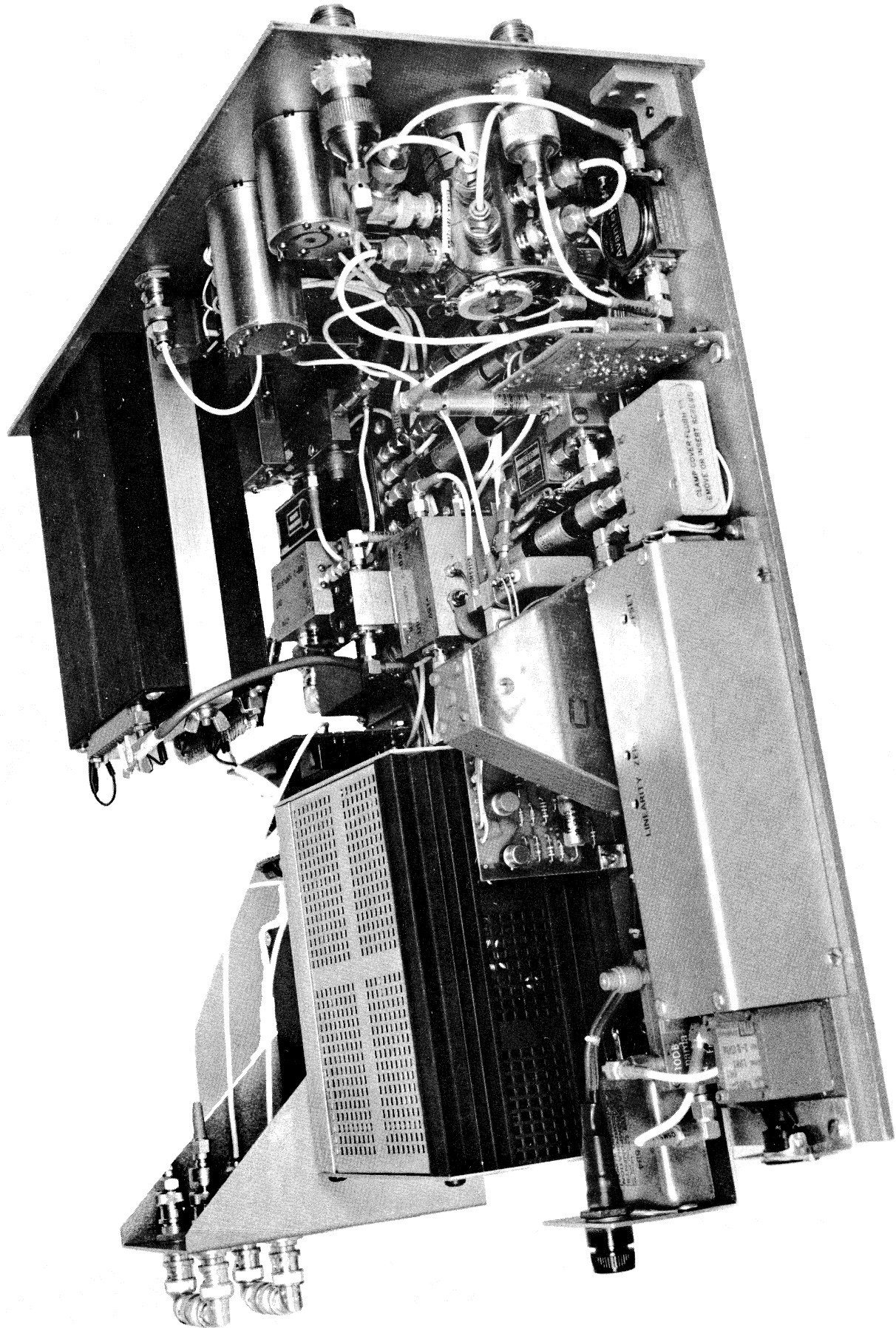

Figure 7 — Photo of Unit Top

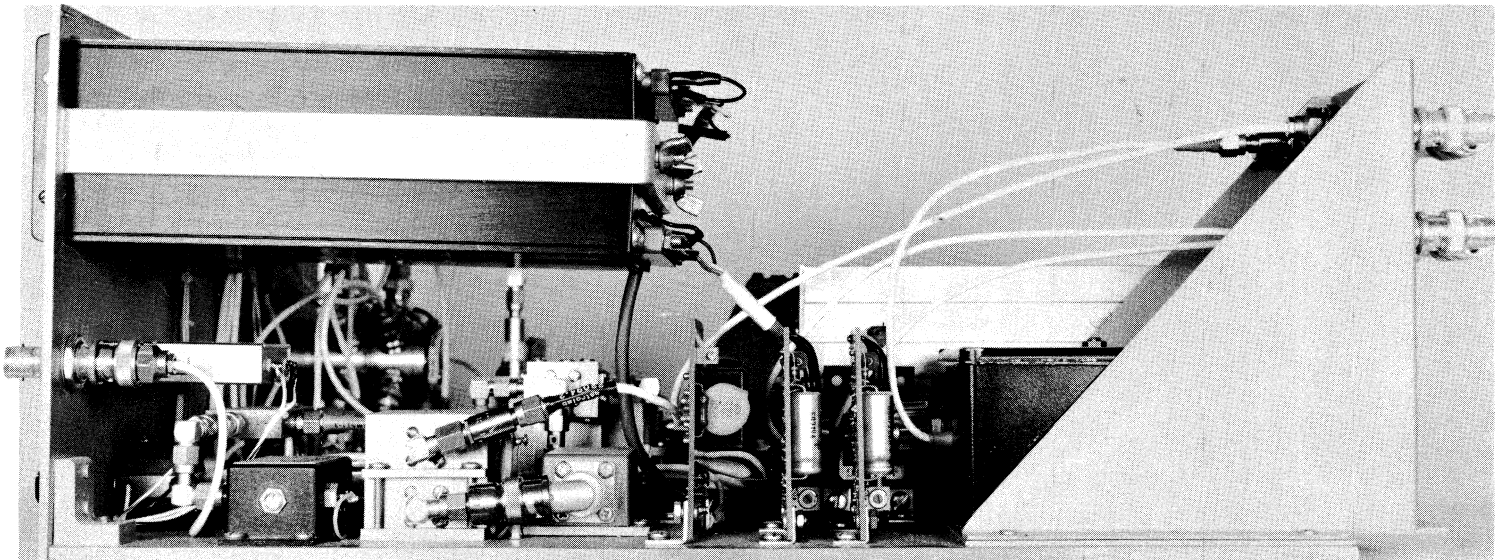
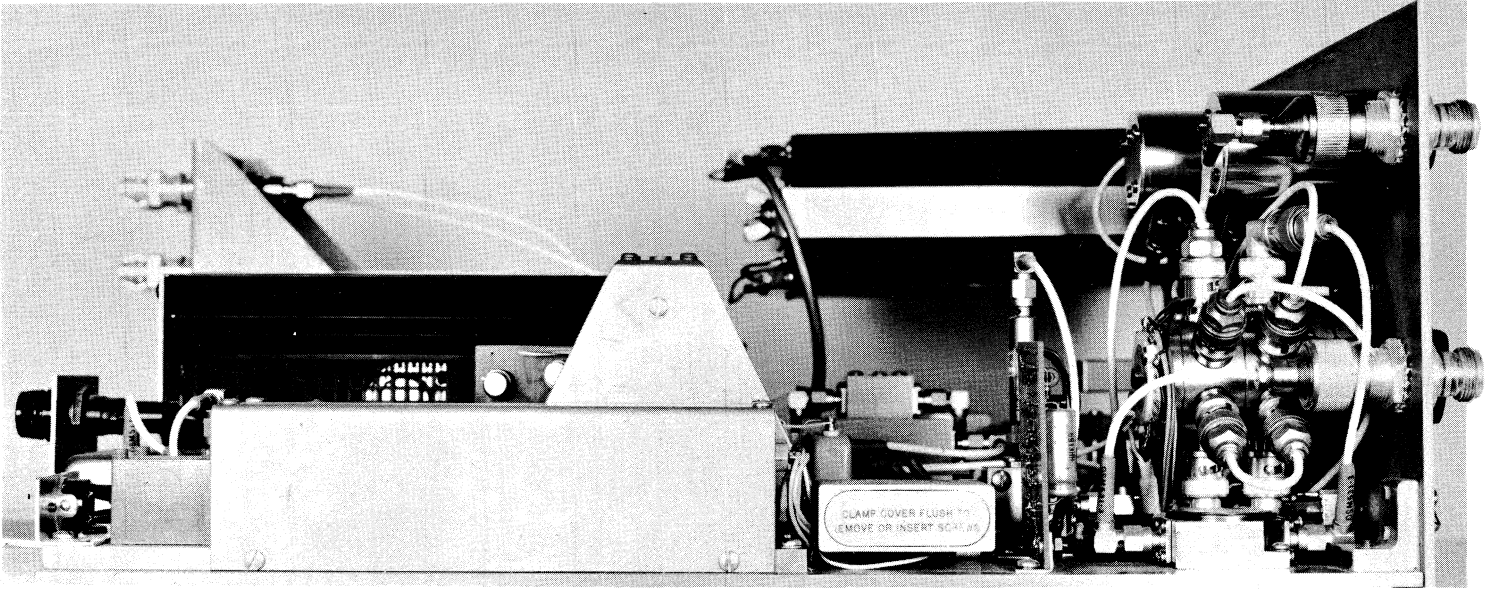

Figure 8 — Photo of Unit Sides