

NATIONAL RADIO ASTRONOMY OBSERVATORY
Green Bank, West Virginia

Electronics Division Internal Report No. 113

3-ELEMENT INTERFEROMETER
3.7, 11, AND 21 CM
RECEIVERS

James R. Coe

NOVEMBER 1971

NUMBER OF COPIES: 150

3-ELEMENT INTERFEROMETER 3.7, 11, AND 21 CM RECEIVERS

James R. Coe

This report describes the interferometer receivers and local oscillator systems used for 3.7 cm, 11 cm, and 21 cm observations.

3.7 and 11 cm Electronics

The 3-element interferometer was instrumented for 3.7 and 11 cm measurements in May 1970. It is capable of receiving and processing both right and left hand circular-polarized double-sideband signals centered at 8085 or 2695 MHz, or one polarization at each frequency.

Front-End Boxes

The front-end boxes on each of the three antennas contain a dual frequency-dual polarization feed, four parametric amplifiers, four mixer preamps, and four IF amplifiers. It also contains a pump and local oscillator source package, a phase-lock-loop package, a receiver control box and calibration and monitoring components as shown in Figure 1. The feed is constructed with the 3.7 cm horn centered in the 11 cm horn. Dielectric polarizers are used to convert the circularly polarized waves to orthogonal, linearly-polarized waves. These waves are then coupled to the output ports of the dual mode transducers. The paramps are degenerate with the pump frequency twice the local oscillator frequency. The receivers amplify and down convert both the upper and lower sidebands. Phase shifters are provided to phase the pump and local oscillator signals to optimize the paramp-mixer gain. The system temperatures are approximately 100 °K at 11 cm and 120 °K at 3.7 cm.

The pump and local oscillator pump package generates synchronous pump and LO signals for the 3.7 cm and 11 cm receivers as shown in Figure 1. The package contains a voltage controlled crystal oscillator. The frequency of this oscillator is controlled by the error signal from the phase-lock-loop box. A phase-locked oscillator is locked to the crystal oscillator and generates 1347.5 MHz. The 1347.5 MHz signal is amplified to 9 watts. This signal is split three ways through couplers. The 100 milliwatt 1347.5 MHz is sent to the phase-lock-loop box for phase comparison. The 800

milliwatt 1347.5 MHz signal drives a X4 frequency multiplier to generate the 5390 MHz pump signals for the S-band receivers. The 2695 MHz signal is multiplied by 3 to generate 8085 MHz for the X-band local oscillator. The 8085 MHz signal also drives a X2 frequency multiplier to generate the 16,170 MHz X-band paramp pump signals.

The receiver control box monitors the paramp and mixer current and controls the pump power to keep the paramp bias current constant.

The calibration components permit injection of broadband noise at a 50 Hz rate into the paramps to provide a continuous monitor of system noise temperatures. X-band and S-band sweep signal generators are provided to measure paramp gain.

The model numbers, manufacturers, and specifications of the major components are listed in Table 1.

Local Oscillator System

The interferometer local oscillator system was installed in May 1967. The original voltage controlled triode oscillators have been replaced with solid state units.

Block diagrams of the local oscillator systems are shown in Figures 2 and 3. The local oscillator system minimizes the phase changes due to cable temperature variations and maintains a fixed phase relationship between the oscillators in each front-end box. A 1317.5 MHz signal and 30 MHz signal are sent to the telescope from the interferometer control building. The 1347.5 MHz oscillator in each front-end box is locked to the sum of these two frequencies. Part of the 1347.5 MHz signal is sent back to the control building and its phase is compared with the local 1317.5 and 30 MHz signals. As shown in Figure 3, a line stretcher is used to maintain the round trip phase constant which reduces the phase errors in the loop by a factor of $\frac{30 \text{ MHz}}{1317.5 + 1347.5} \simeq \frac{1}{90}$. With the phase shifters operating the daily phase variation due to cable temperature changes is less than 0.5 degrees at 1347.5 MHz.

Lobe Rotation

The capability of adjusting the phase of the local oscillator system to reduce the interferometer fringe frequencies to zero was added to the interferometer LO system in June 1971. The phase of the 30 MHz reference signals to each telescope is controlled by the computer. The computer controls the phase difference and the frequency of the

TABLE I
3.7 and 11 cm Dual-Polarization Front-End Components

| Component | Manufacturer | Specifications | | | | | | | | | | | | |
|---|--|---|-----------|-----------|------------|-------------|----------|------------|----------|-------------|----------|------------|-------------|-------------|
| Interferometer Feed Assembly SKJB69033 I | RCA Missile and Radar Division | Frequency 2645 to 2745 MHz 8035 to 8135 MHz. VSWR less than 1.1 to 1. Axial Ratio less than 1.03 average. | | | | | | | | | | | | |
| <u>Params</u> 2695 MHz Degenerate Para- metric Amplifiers, P/N 28872 8085 MHz Degenerate Para- metric Amplifiers, P/N 28468 | Micromega, Division of Bunker Ramo | Gain 17 dB. 1 dB Bandwidth 2695 ± 45 MHz. Noise Temperature 45 °K. Gain 17 dB. 1 dB Bandwidth 8085 ± 60 MHz. Noise Temperature 60 °K. | | | | | | | | | | | | |
| <u>Mixers</u> 2695 Mixer, P/N HO 424 8085 Mixer, P/N HO 425 | Microphase Corporation | Gain 25 dB. IF 1 dB Bandwidth 2 to 60 MHz. Noise Figure DSB 5.5 dB. Noise Figure DSB 7 dB. | | | | | | | | | | | | |
| <u>IF Amps</u> Model S-5469 | Comdel, Inc. | 40 dB Gain. 1 dB IF Bandwidth 5-40 MHz. 1 dB Compression +22 dBm. | | | | | | | | | | | | |
| <u>Pump and LO Source</u> Model 503634 | Applied Research, Inc. | <table border="1"> <thead> <tr> <th data-bbox="930 909 979 1056">Frequency</th> <th data-bbox="930 909 979 1056">Power Out</th> </tr> </thead> <tbody> <tr> <td data-bbox="979 909 1027 1056">1347.5 MHz</td> <td data-bbox="979 909 1027 1056">100 mW min.</td> </tr> <tr> <td data-bbox="1027 909 1076 1056">2695 MHz</td> <td data-bbox="1027 909 1076 1056">10 mW min.</td> </tr> <tr> <td data-bbox="1076 909 1125 1056">5390 MHz</td> <td data-bbox="1076 909 1125 1056">100 mW min.</td> </tr> <tr> <td data-bbox="1125 909 1174 1056">8085 MHz</td> <td data-bbox="1125 909 1174 1056">12 mW min.</td> </tr> <tr> <td data-bbox="1174 909 1222 1056">16, 170 MHz</td> <td data-bbox="1174 909 1222 1056">120 mW min.</td> </tr> </tbody> </table> | Frequency | Power Out | 1347.5 MHz | 100 mW min. | 2695 MHz | 10 mW min. | 5390 MHz | 100 mW min. | 8085 MHz | 12 mW min. | 16, 170 MHz | 120 mW min. |
| Frequency | Power Out | | | | | | | | | | | | | |
| 1347.5 MHz | 100 mW min. | | | | | | | | | | | | | |
| 2695 MHz | 10 mW min. | | | | | | | | | | | | | |
| 5390 MHz | 100 mW min. | | | | | | | | | | | | | |
| 8085 MHz | 12 mW min. | | | | | | | | | | | | | |
| 16, 170 MHz | 120 mW min. | | | | | | | | | | | | | |

10 kHz signals generated in the digital lobe rotator. The digital lobe rotator is described in NRAO Electronics Division Internal Report No. 100 by R. Hallman. The 10 kHz signals are mixed with 29.990 MHz from a crystal oscillator as shown in Figure 2. The upper side band (30 MHz) is passed through the crystal filter, amplified and sent to the phase comparators and then to the telescopes. As shown in Figure 2, the interferometer local oscillator system can be locked to a rubidium standard for VLB runs. The VLB LO synthesizer designed by R. Mauzy is utilized to generate the 1317.5 MHz local oscillator RF signal from the 5 MHz VLB reference signal. The 30 MHz is generated by doubling the 5 MHz reference signal and feeding this signal into the X3 multiplier and power amplifier to generate the local oscillator 30 MHz IF signal.

The major components used in the local oscillator system are listed in Table 2.

11 cm and 3.7 cm IF Processing

The four IF signals from each front-end receiver are brought to the equipment building at the base of each telescope on 1/2 inch semi-rigid cable. RG-9 jumpers are used at the focal point and around the polar and declination axis. A block diagram showing the IF equipment at each antenna is shown in Figure 4. A patch panel is provided in each signal path for equalizing cable lengths. The gain of the IF amplifier is adjustable and is used to match the amplitudes of the four IF signals. A channel selection relay selects the two IF signals that are sent to the control building. The 3.7 cm or X-band IF signals are designated XR for the right-hand circularly-polarized output and XL for the left-hand circularly-polarized outputs. The 11 cm or S-band IF signals are designated by SR and SL. Amplitude equalizers are provided to equalize the cable attenuation with frequency over the IF frequency band of 5 to 35 MHz. A total power monitor is also provided for each of the four receiver outputs.

The IF signals are transmitted to the Interferometer Control Building through buried 1/2 inch semi-rigid cable. The IF processing system at the control building is shown in Figure 5. Two IF signals from each antenna are processed. The IF signals are amplified and the total power is monitored in the IF monitor section. The IF signal is then routed through the delay system, through the IF Level Control Section and to the correlators. The delay system consists of a set of 14 binary delay elements with the smallest 1.9 nanosec and the longest 16 μ sec for a total delay range of 0 to 31.998 μ sec.

TABLE 2

Local Oscillator System Components

| Master Oscillator | Manufacturer | Specifications |
|---|--|--|
| <u>Component</u> Vectron Crystal Oscillator Model CO-228 | Vectron Laboratories, Inc. | Output 101.346154 MHz. Power output 5 milliwatts. Stability 3 parts in 10^8 per day. |
| Micromega Phase Locked Signal Source Model | Micromega, Division of Bunker Ramo | Frequency output 1317.5 MHz. Power output 250 mW. |
| Power Amplifier Model SA1375 | Sanders Associates | Frequency bandwidth 1317.5 \pm 5 MHz. Power output 2 watts, gain 10 dB. |
| Power Divider Interferometer LO Distribution Package No. 1, Model AL-19 | Hyletronics Corporation | |
| 1317.5 MHz Filters Telonic TBA 1317.5-27-6551 | Telonic Engineering Co. | 1304-1331 MHz 3 dB points 1290-1344 MHz 30 dB points Insertion loss 4 dB |
| LO Frequency Counter HP Model 5245L with 5254 Plug In | Hewlett Packard | Time base stability < 3 parts in 10^9 per day. |
| <u>Lobe Rotation</u> Vectron Crystal Oscillator Model CO-222 | Vectron | Output 29.990 MHz Stability 3 parts in 10^8 per day. |
| Damon Crystal Filter | Damon Electronics Division | Center frequency 30 MHz 6 kHz bandwidth 60 dB at 29.990 MHz. |
| LEL 30 MHz Amplifier Limiter Model IF 6904 | LEL Division of Varian | 30 MHz center frequency Output level + 16 dBm. |

The delay system contains 5 quartz ultrasonic delay lines which have a center frequency of 60 MHz. The IF signal of 5 to 35 MHz is mixed with a 40 MHz signal to convert it up to 45 to 75 MHz for transmission through the delay elements. It is then converted back down to 5 to 35 MHz using the same 40 MHz signal and sent to the IF level control section. The IF level control system holds the IF level into the correlators constant at 1 milliwatt. The gain of the IF amplifier is varied to keep the IF level detector output constant.

The IF level detector output is also used to provide a noise temperature monitor. The noise modulation injected into the paramps in each front-end is synchronously detected. The change in synchronous detector output is proportional to

$$\frac{1}{1 + \frac{\Delta T}{T_{\text{sys}}}}$$

where ΔT is the change in system temperature and T_{sys} is the initial system temperature.

The IF signal from the level control section is sent to the six-way power divider in the correlator section. A six-way divider was utilized to provide parallel and cross-polarization correlators for a four-element dual-polarization interferometer. At the present time only 12 of the 24 correlators provided are utilized. The correlator consists of a double-balanced mixer and a DC amplifier with a low-pass bandwidth of 10 Hz. The correlator amplifier gain steps are 50, 500, and 5000 for the parallel-polarized signals and 500 and 5000 for the cross-polarized correlators. These gains are controlled by the interferometer on-line computer.

21 cm Electronics

The interferometer was instrumented for 21 cm line measurements in June 1971. The additions to the existing interferometer consist of a 21 cm feed and receiver for each antenna. IF converters, Lobe Rotators, and the Digital Correlation Receiver Model III are required at the interferometer control building.

21 cm Front End

The 21 cm feed is mounted over the existing interferometer feed and connected to the receiver through 7/8 inch rigid air line cable. The receiver is mounted on a plate in the 3.7 and 11 cm front-end box. Figure 6 shows the 21 cm receiver and Table 3 lists the major components. The paramp is non-degenerate with a pump frequency of 20.815 GHz. The paramp has a gain of 18 dB with a 1 dB bandpass of 1370 to 1430 MHz. The pump source is an avalanche diode oscillator followed by a tripler to generate 80 milliwatts. The 1347.5 MHz signal from the interferometer phase-locked oscillator in each front-end box is used as a local oscillator signal for the mixers. The IF frequency band is from 22.5 to 82.5 MHz. The IF signal is sent to the base of the antenna through 1/2 inch semi-rigid cable and the total power is monitored at the antenna.

The IF signal is transmitted to the interferometer control building through one of the buried semi-rigid coax lines.

At the control building the IF signals are converted to a 30 MHz wide band centered at 20 MHz for transmission through the delay system, IF level control, and to the correlators.

The IF processing is shown in Figure 7. The input signal from the telescope is amplified, part of the signal is coupled into the IF monitor detector and the remainder converted up to a 30 MHz band centered at 120 MHz. After the IF signal is filtered in the 105 to 135 MHz filter, it is mixed with the 140 MHz to give a signal of 5 to 35 MHz. This signal is then sent through the delay system, the IF level control and to the correlators. The correlators are connected to give a sin and cosine component for each of the three baselines. The analog correlator arrangement is shown in Figure 7. Part of the IF signal (5 to 35 MHz) is mixed with 40 MHz to provide a 10 MHz wide signal centered at 30 MHz for processing by the Digital Correlation Receiver Model III. Therefore, the digital correlator processes the frequency spectrum which was centered at 10 MHz as it passed through the delay system. This minimizes phase changes as the delays switch. Each delay step of 1.9 nanosecs causes 6.8° phase shift at 10 MHz.

The portion of the RF input spectrum which is processed by the digital correlator is determined by the frequency synthesizer. The frequency synthesizer is computer controlled. The digital control is described in the NRAO Electronics Division Internal Report No. 102 by D. Schiebel. The frequency synthesizer setting can be determined

TABLE 3
21 cm Receiver Components

| Component | Manufacturer | Specifications |
|--|-------------------------------------|--|
| L-Band Scalar Feed | Control Data Corporation | Frequency range 1360-1440 MHz. Polarization linear. VSWR < 1.2 |
| 7/8" Coax Coupler Model SP9266 | Maury Microwave Corporation | Coupling 30 dB. VSWR 1.04 maximum. Insertion loss .02 dB. |
| Parametric Amplifier Model 26339 | Micromega | 1 dB bandwidth 1320 to 1430 MHz. Noise temperature 60 °K maximum. Gain 18 dB. Pump power < 50 milliwatts. |
| Sylvania K-Band Source SYG-2030 | Sylvania Electronic Components | Output frequency 20, 815 ± 50 MHz. Power output 80 milliwatts. |
| Alternate Source Pump Oscillator Part No. 12110-33633 and Diode Attenuator, Part No. 34165 | Micromega | Output frequency 20, 815 MHz. Power output 80 mW. .6 to 20 dB +8 to -8 V. |
| Transistor Amp SP-1405/70 Part No. 31-023873-01 | Applied Technology, Div. of Itek | 3 dB bandpass 1200 to 1460 MHz. Gain 25 dB. Noise figure 4 dB. |
| Mixer Preamp MMC60-1405-55-90 | International Microwave Corporation | Center frequency 1405 MHz. RF to IF Gain 60 dB. 1 dB IF Band 10 to 110 MHz. Noise figure 9 dB maximum. |

by subtracting 1217.5 MHz from the required observing frequency. For example, to receive and process 1420 MHz the synthesizer setting would be 202.5 MHz.

The 21 cm system is operated single sideband and IF path length changes shift the phase of the correlator outputs. The 3.7 and 11 cm systems are double sideband systems and the correlator output phase is independent of IF path length changes.

CONTRIBUTORS

The development of the interferometer electronics described in this report has required assistance from most of the NRAO Electronics Division and Machine Shop personnel. M. Balister and S. Weinreb provided general design guidance. K. Wesseling designed the local oscillator system. R. Mauzy designed the paramp controls and mixer current monitors, and monitored development of the pump and local oscillator sources. The front-end box temperature controllers were designed by J. Payne and constructed by R. Becker. J. Payne designed and S. Mayor constructed the noise tube power supplies. J. Davis designed the system malfunction detector. O. Bowyer, D. Williams, and M. Barkley designed the dual-frequency feed and 21 cm feed mounting system. A. Miano provided considerable assistance in designing the layout for the front-end box. R. Ervine, J. McCormack, J. Oliver and W. Shank constructed and tested the receivers, IF processing and local oscillator systems.

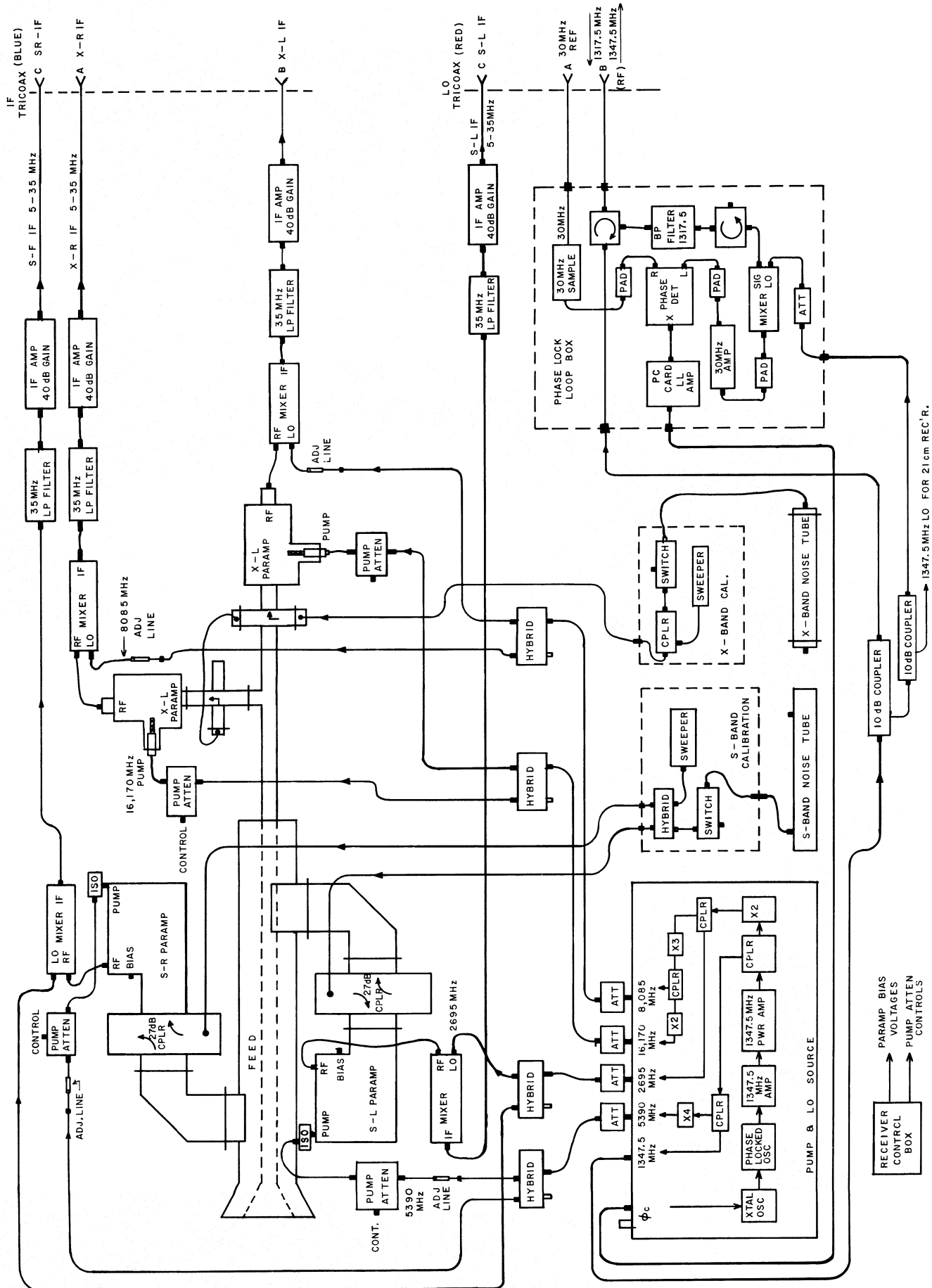

3.7 cm & 11.1 cm - DUAL POLARIZATION INTERFEROMETER FRONT END

FIG. 1

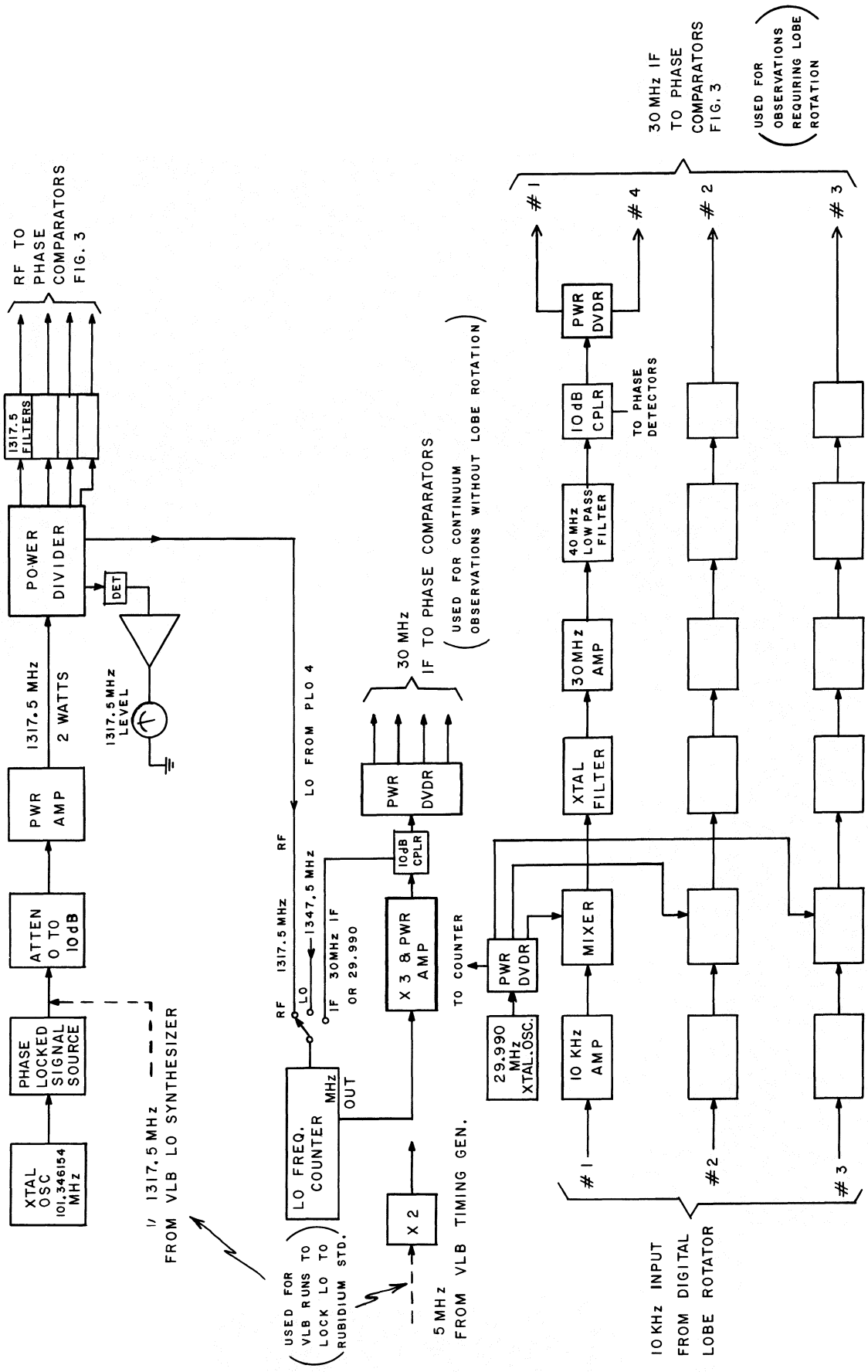

INTERFEROMETER LOCAL OSCILLATOR SYSTEM MASTER OSCILLATOR

FIG. 2

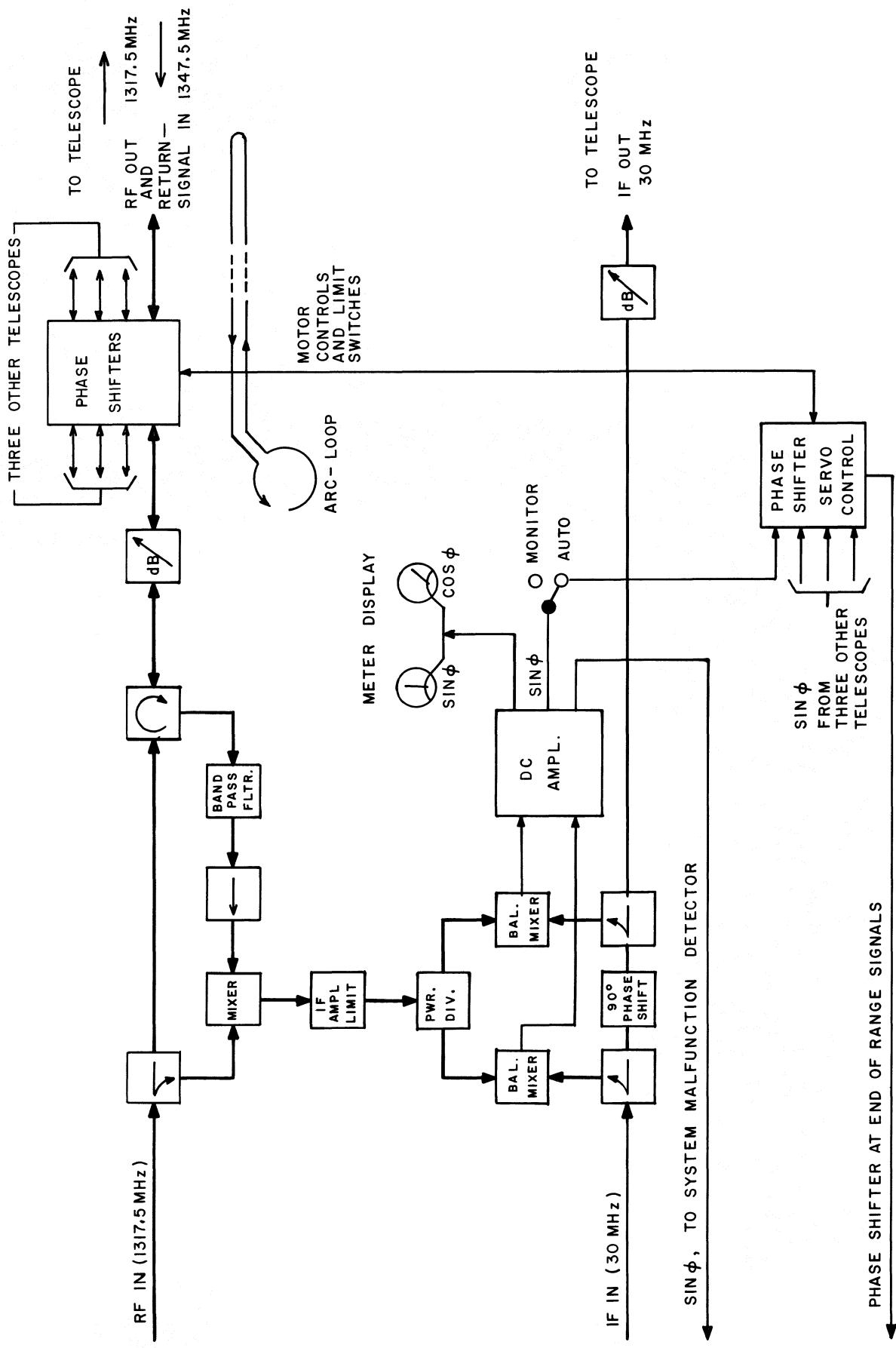

INTERFEROMETER LOCAL OSCILLATOR SYSTEM PHASE COMPARETOR & CONTROLLER

FIG. 3

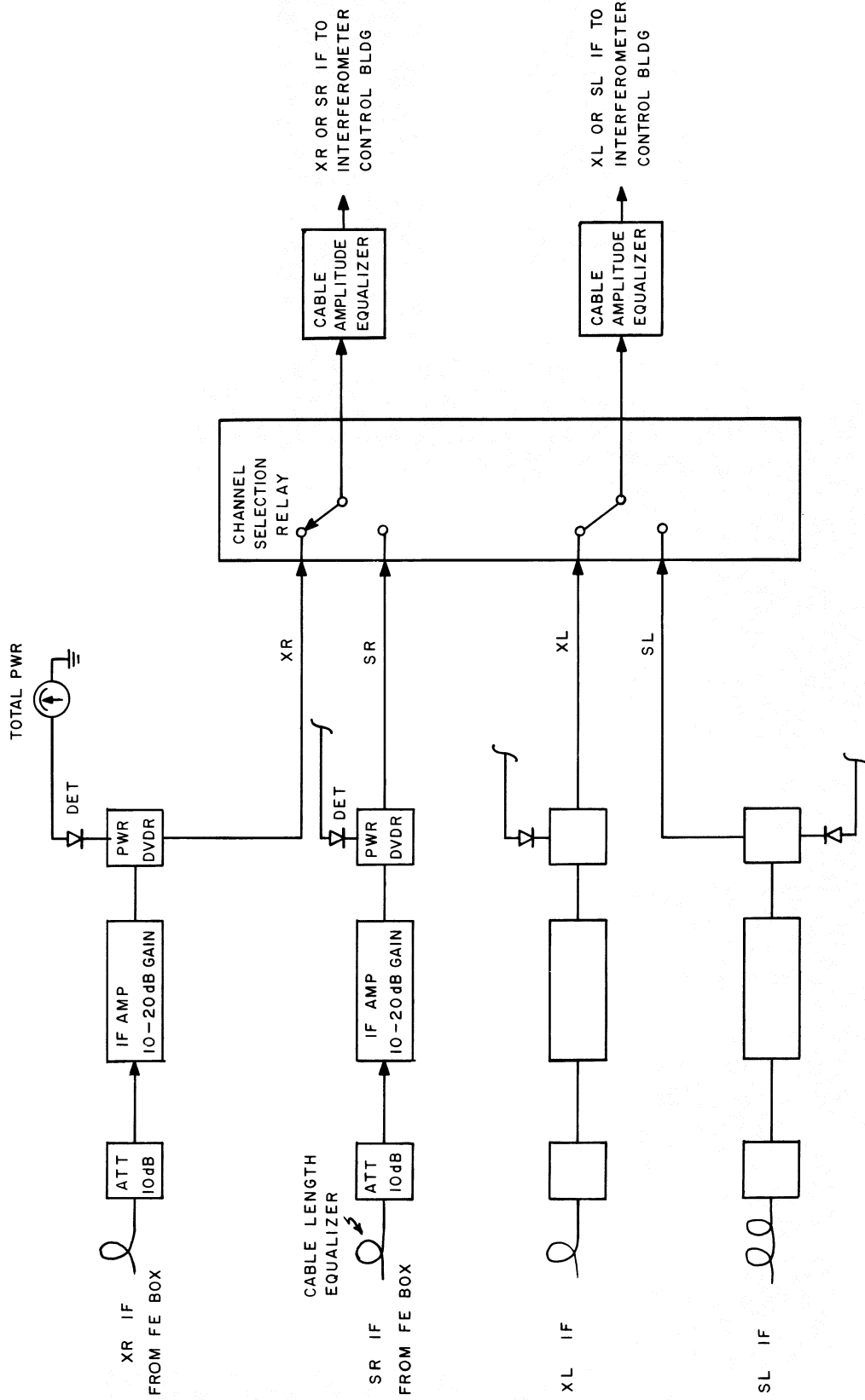

RECEIVER IF PROCESSING AT ANTENNA EQUIPMENT BLDG.

FIG. 4

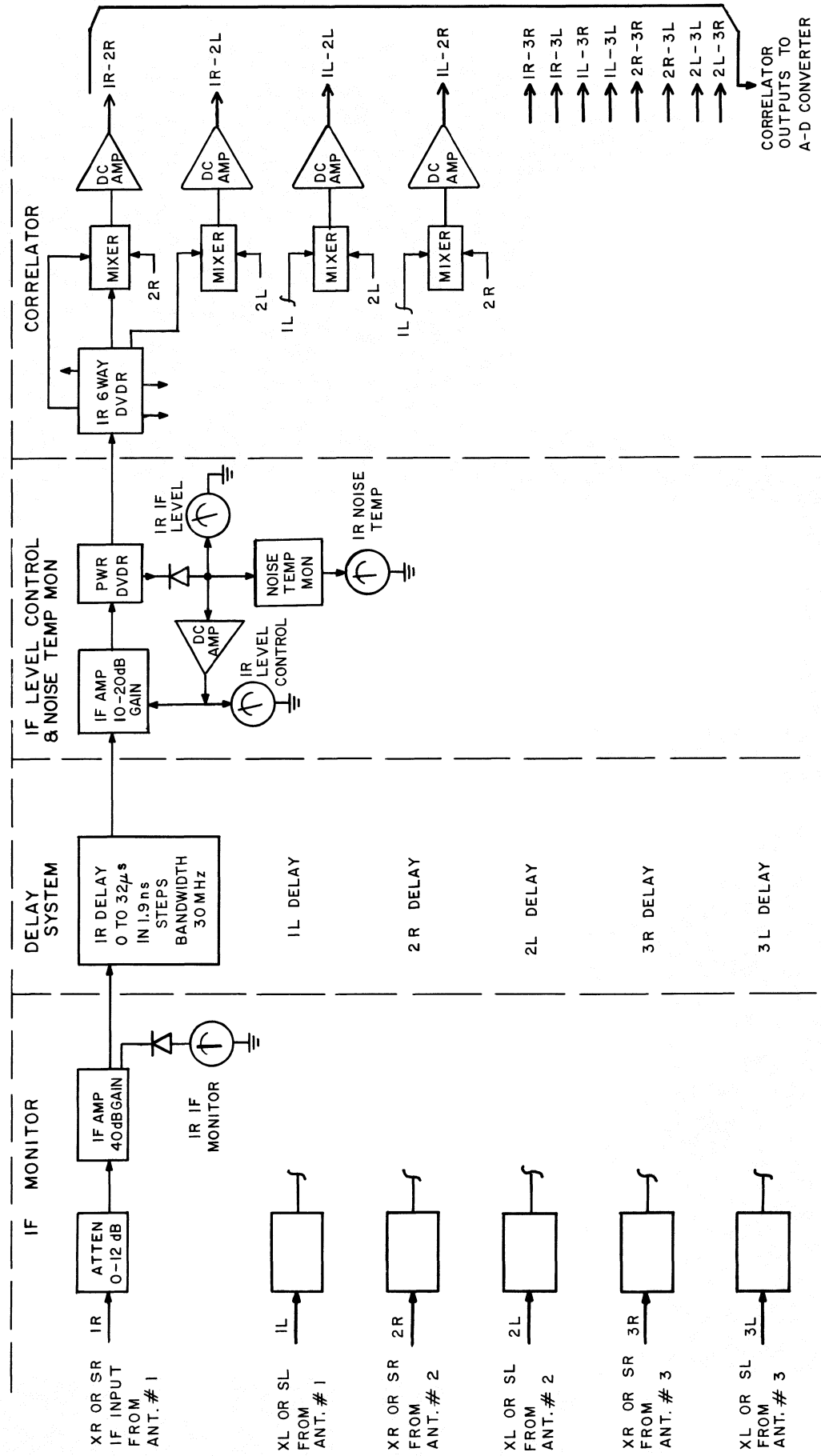

INTERFEROMETER CONTROL BUILDING IF PROCESSING

FIG. 5

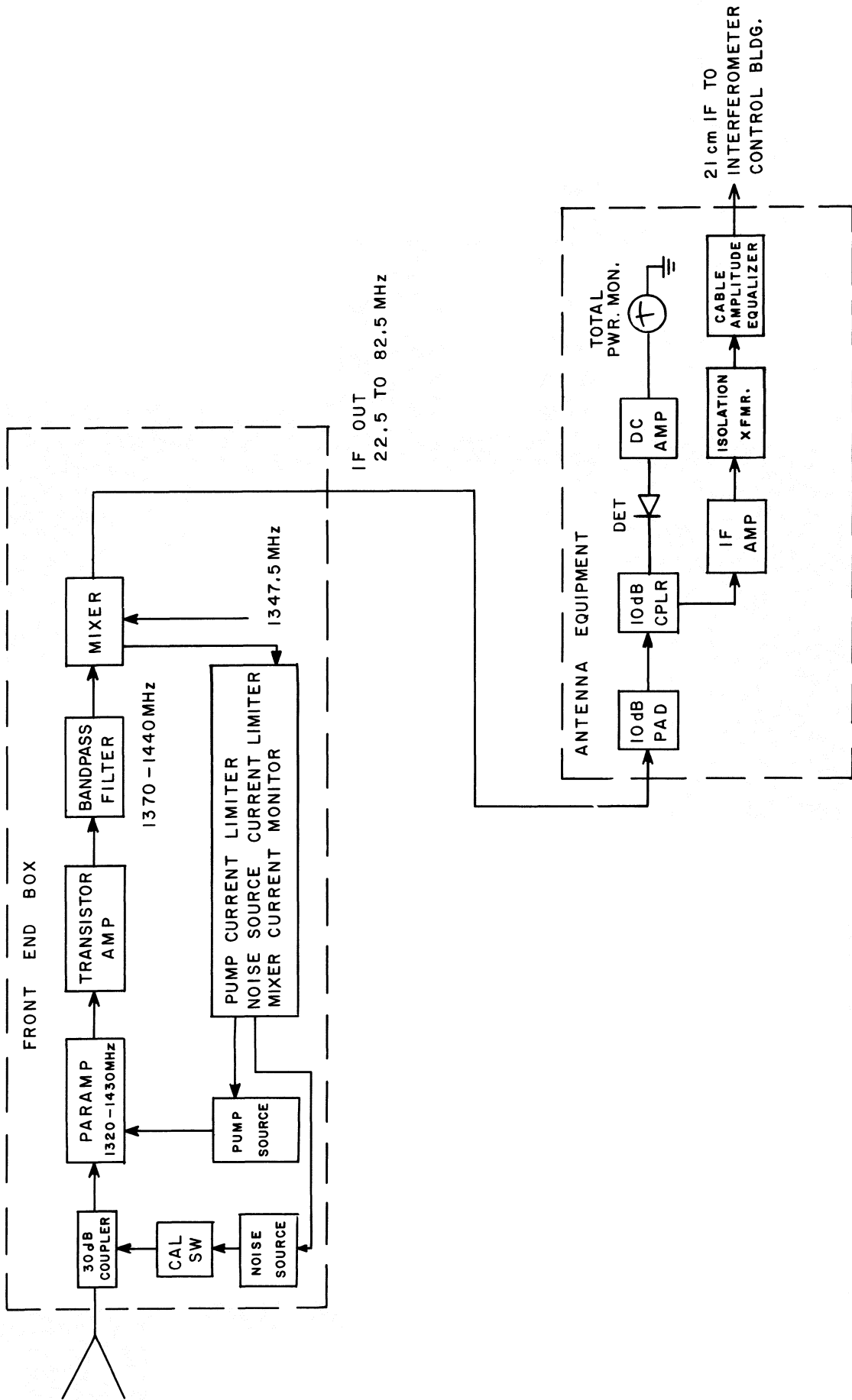

21 cm FRONT END

FIG. 6

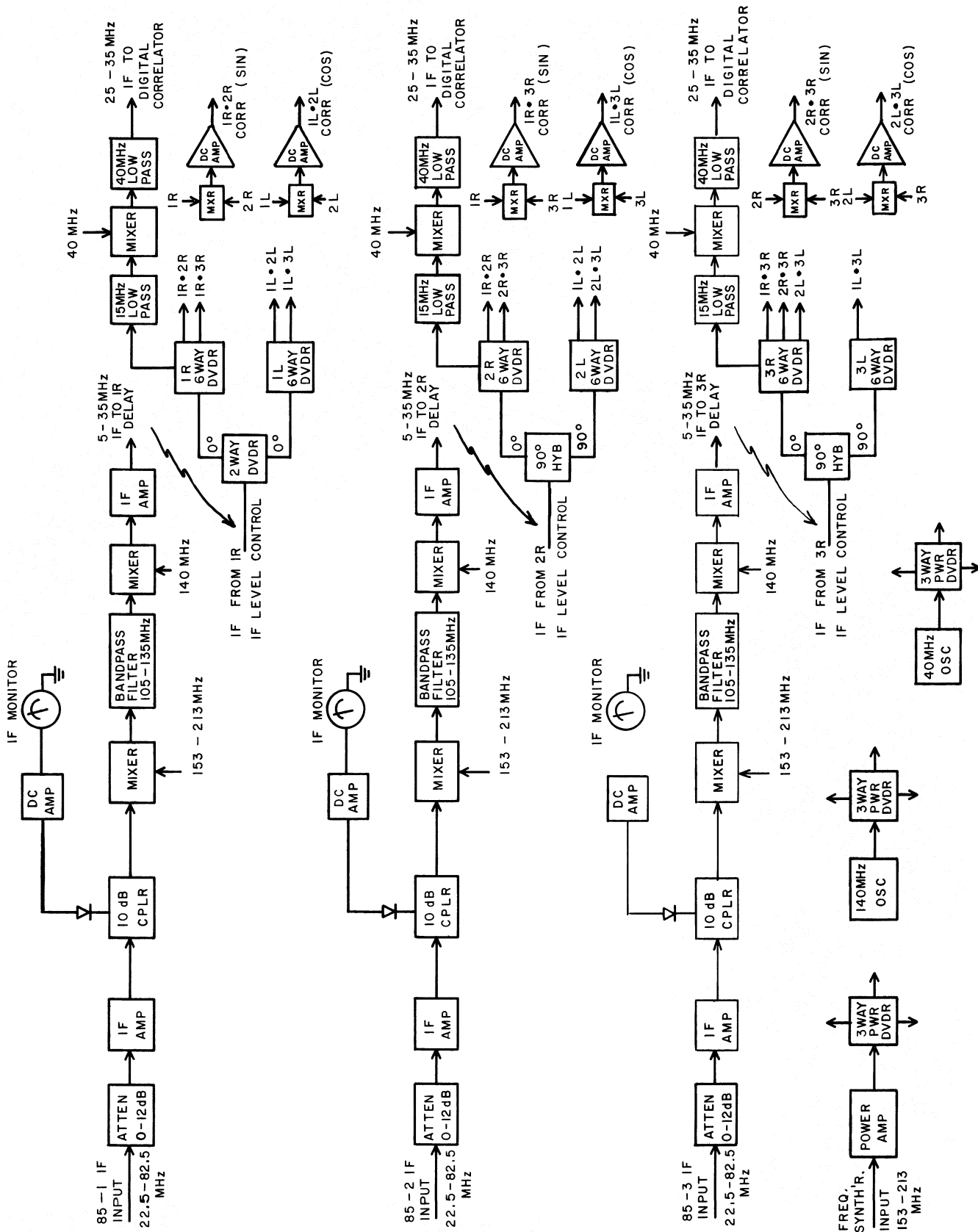

LINE SYSTEM IF PROCESSING

FIG. 7