

NATIONAL RADIO ASTRONOMY OBSERVATORY
Green Bank, West Virginia

Electronics Division Internal Report No. 112

A 50-CHANNEL MULTIFILTER RECEIVER
(250 kHz BANDWIDTH PER CHANNEL)

Michael Balister

NOVEMBER 1971

NUMBER OF COPIES: 150

A 50-CHANNEL MULTIFILTER RECEIVER
(250 kHz BANDWIDTH PER CHANNEL)

Michael Balister

General

This multifilter receiver is the latest of a set of receivers which have been described previously in NRAO/EDIR Reports Nos. 70 and 88. The first three receivers (100 kHz, 1 MHz, 5 MHz bandwidth per channel) were built using filters with different center frequencies to analyze the band. Later receivers used identical filters in each channel; each section of the frequency band to be analyzed was converted to this common filter frequency of 10.7 MHz. The three NRAO receivers using this technique had filter bandwidths of 10 kHz, 30 kHz, and 100 kHz. Eight-pole, quartz crystal networks built by C. F. Networks were used in these receivers.

The receiver described in this report uses this identical filter technique and has a 250 kHz bandwidth per channel. This receiver may be used either as a set of contiguous filters or as two identical sets of 25 filters. The input frequency is 150 MHz, and the total power outputs go to a computer via an A/D converter and multiplexer (EDIR No. 101). A CRT displays the spectra.

The receiver is completely self-contained and operates from 115 volts.

Description

The filters are ceramic and are manufactured by Gould/Clevite; the data sheet is reproduced in Figure 1. Figure 2 shows the change in center frequency vs. temperature. Two channels are built on one circuit card with a common local oscillator; Figure 3 shows the circuit. The RF inputs are on pins D and H and are in the frequency range 30 ± 6.25 MHz; Table 1 lists the channel number, signal frequency and crystal frequency. Channels 1 and 26, 2 and 27, etc., are on the same circuit cards. This receiver is different from previous ones in one respect: MC 1596G integrated circuit balanced mixers are used instead of the more conventional transformer/diode ones (i. e. , Relcom M6A). Despite the extra components necessary, these mixers were used because they have a small gain and are also easy to drive from the local oscillator.

An MC 1023 MECL 2 digital integrated circuit, normally used as a fast gate, was used as a crystal oscillator. The crystal must be a fundamental mode one and is connected between the output and input. A 1.30 V bias on pin 5 sets the circuit in its amplifying mode, i. e. , mid-way between a 0 and a 1. The second gate is driven from the first to provide a balanced drive for the second mixer.

The filter is driven from a 10.7 MHz tuned circuit which is between the mixer collectors. The tuned circuit was loaded to the point where the bandwidth was wider than that of the ceramic filter. The BD7 back diode has been used as a square law detector in all of our previous receivers and is used again in this one. Its two advantages are (1) relatively insensitive to temperature and (2) good square law characteristics at power levels up to -20 dBm.

An Analog Devices AD741KN integrated circuit operational amplifier was used; it was felt that the somewhat higher voltage drift with temperature of this amplifier, when compared with those used previously, was unimportant. The DC output of each channel is measured at the commencement of each scan, with the input signal removed. The output of each channel when taking data is then corrected for this DC offset, making its magnitude unimportant, provided its changes are slow.

There are four adjustments for each channel: (1) tune mixer output to 10.7 MHz; (2) set zero; (3) set gain; and (4) detector law.

Input Circuitry

There are two 150 MHz IF inputs; A input only is used in the series mode, and A and B inputs are used in the parallel mode. Both inputs go to a diode switch which is used to isolate the inputs when the CHECK ZERO signal is received from the computer. Figure 5 details the frequency conversion to 30 MHz and Series/Parallel RF switching. In the parallel position the 120 MHz oscillator is used; in the series mode two oscillators are used in order to displace channels 1-25 and 26-50 by 6.25 MHz. This results in 50 contiguous channels, the center frequencies of the channels in both modes are listed in Table 2. The oscillator circuit is shown in Figure 6.

The first 30 MHz amplifier is NRAO made, Figure 7. The driver amplifier for the boards is an Anzac WBHV-30G-27. The 1 dB output compression point is +23 dBm.

Figure 8 shows the front panel and top views of the receiver.

Monitor Circuitry

Figure 5 shows this also. The four power supplies are read on the front panel meter; when correct they should all read center scale. The total power in individual channels is monitored with the front panel switches.

Power Supplies

Four Lambda power supplies are used to produce the +5, ± 15 and -22 V supplies.

Model	Voltage	Current at 40 °C
LCS-3-01	0 - 7 V	1.2 A
LCS-3-03	0 - 32 V	400.0 mA
LCD-4-22	0 - 18 V	1.0 A
	0 - 18 V	1.0 A

Set-Up Procedures

1) Set gain pots at minimum gain (clockwise). Set law pots at maximum resistance (500 ohms) clockwise.

2) With no input it should be possible to zero the output voltage from each channel.

3) With input from swept frequency source, look at the bandpass of the channels at the TP output BNC test point (saturated output is 10 V). The tuned circuit trimmer will have to be adjusted for maximum output and flattest bandpass.

With the channel gain set to maximum, a CW input signal of typically -22 dBm is required to give a 1 volt output from the detector amplifiers. Figure 4 shows typical bandpasses for both channels of one of the filter boards.

The detector law adjustment potentiometers were all set to 500 ohms in both the receivers built. We are considering temperature control of the air stream which blows over the boards. We may then try some ideas which may enable one to measure and correct the square law characteristics more accurately than has been previously possible.

TABLE 1

Channel	Number	Channel Center Frequency	Local Oscillator
1	26	27.000	16.300
2	27	.250	.550
3	28	.500	.800
4	29	.750	17.050
5	30	28.000	.300
6	31	.250	.550
7	32	.500	.800
8	33	.750	18.050
9	34	29.000	.300
10	35	.250	.550
11	36	.500	.800
12	37	.750	19.050
13	38	30.000	.300
14	39	.250	.550
15	40	.500	.800
16	41	.750	20.050
17	42	31.000	.300
18	43	.250	.550
19	44	.500	.800
20	45	.750	21.050
21	46	32.000	.300
22	47	.250	.550
23	48	.500	.800
24	49	.750	22.050
25	50	33.000	.300

TABLE 2

Channel Number		Nominal Center Frequency MHz		Channel Number		Nominal Center Frequency MHz	
		Series Mode	Series Mode			Series Mode	Series Mode
A	1	143.875	147.000	B	26	150.125	147.000
	2	144.125	.250		27	.375	.250
	3	.375	.500		28	.625	.500
	4	.625	.750		29	.875	.750
	5	.875	148.000		30	151.125	148.000
	6	145.125	.250		31	.375	.250
	7	.375	.500		32	.625	.500
	8	.625	.750		33	.875	.750
	9	.875	149.000		34	152.125	149.000
	10	146.125	.250		35	.375	.250
	11	.375	.500		36	.625	.500
	12	.625	.750		37	.875	.750
	13	.875	150.000		38	153.125	150.000
	14	147.125	.250		39	.375	.250
	15	.375	.500		40	.625	.500
	16	.625	.750		41	.875	.750
	17	.875	151.000		42	154.125	151.000
	18	148.125	.250		43	.375	.250
	19	.375	.500		44	.625	.500
	20	.625	.750		45	.875	.750
	21	.875	152.000		46	155.125	152.000
	22	149.125	.250		47	.375	.250
	23	.375	.500		48	.625	.500
	24	.625	.750		49	.875	.750
	25	.875	153.000		50	156.125	153.000

GOULD/CLEVITE

CERAMIC FM FILTER (FM 4)

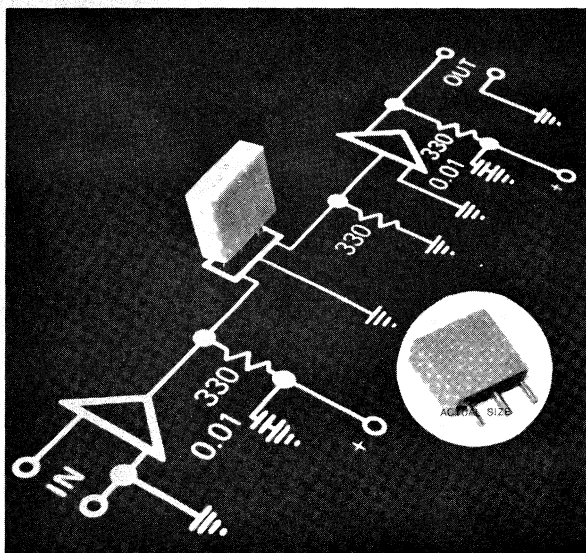

RUGGED, HIGH-SELECTIVITY MINIATURE FOR HI-FIDELITY FM'S

This miniature 10.7 MHz FM filter — a simple monobloc of high-Q ceramic molded in plastic — combines the advantages of very small size and inherent reliability with distortion-free performance, high selectivity and economy both in component cost and cost of circuit manufacture. It is fully compatible with either conventional or integrated circuitry, and allows design of straightforward filtering circuits with fewer interconnections than with conventional filters.

A notable characteristic is the FM 4's high stopband — typically above 45 dB. With a single-filter circuit, adjacent FM channels 400 kHz apart are suppressed at levels nearly 35 dB. Where two FM 4's are used, stopbands above 80 dB can be achieved.

The unique molded-monolithic structure affords the following advantages: compactness and light weight; virtual immunity to shock; integrity of internal connections; improved thermal insulation. Mounting is simple, as leads are evenly spaced, rigid, and designed for PC insertion with allowance for crimping and flow-soldering.

FEATURES

- Miniature Size
- IC-compatible
- Monolithic Reliability
- Lump-Filter Simplicity

APPLICATIONS

The Clevite FM 4 is ideal for FM car radios or portables, where size and shock-immunity are governing considerations; or for FM receivers of highest quality where minimum distortion and high stopband rejection and selectivity are required.

SPECIFICATIONS

	Guaranteed	Typical Characteristics
Center Frequency	10.7 MHz*	10.7 MHz*
3 dB Bandwidth	200 kHz min.; 280 kHz Max.	235 kHz
40 dB Bandwidth	900 kHz Max.	825 kHz
Insertion Loss	5 dB max.	3.5 dB
Ripple	1 dB max.	0.2 dB
Stopband	40 dB min.	47 dB
Impedance	330 ohms $\pm 20\%$ plus 5 pF ± 5	—

* Production sorting delivers five groupings of center frequencies within ± 100 kHz of nominal 10.7 MHz, each with tolerance of ± 25 kHz. Each is color coded for identification

$C_f (\pm 25 \text{ kHz})$	10.625 MHz	10.6625 MHz	10.700 MHz	10.7375 MHz	10.775 MHz
Color	Orange	Yellow	Green	Blue	Violet

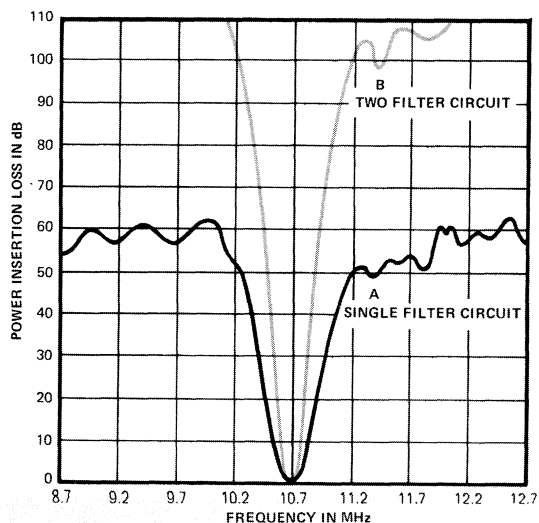

A Typical Single-filter Circuit

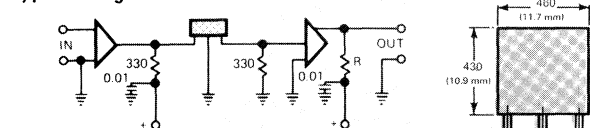

B Typical Two-Filter Circuit

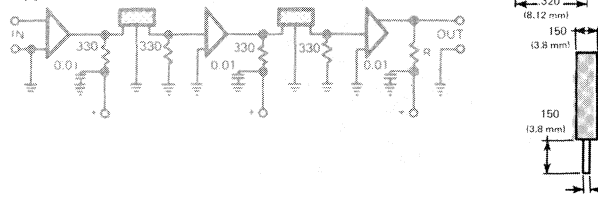

OUTLINE DIMENSIONAL

FIGURE 1

DATA SHEET

CERAMIC FM FILTER (FM 4)

CENTER FREQUENCY VS. TEMPERATURE

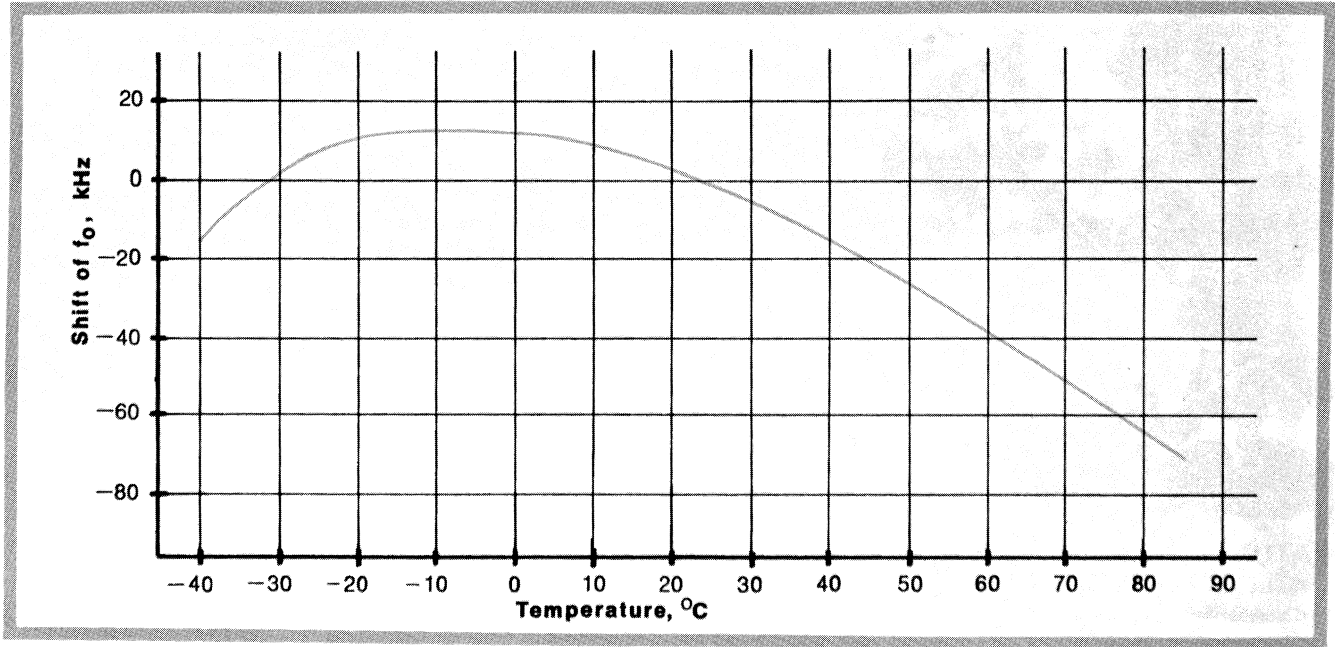
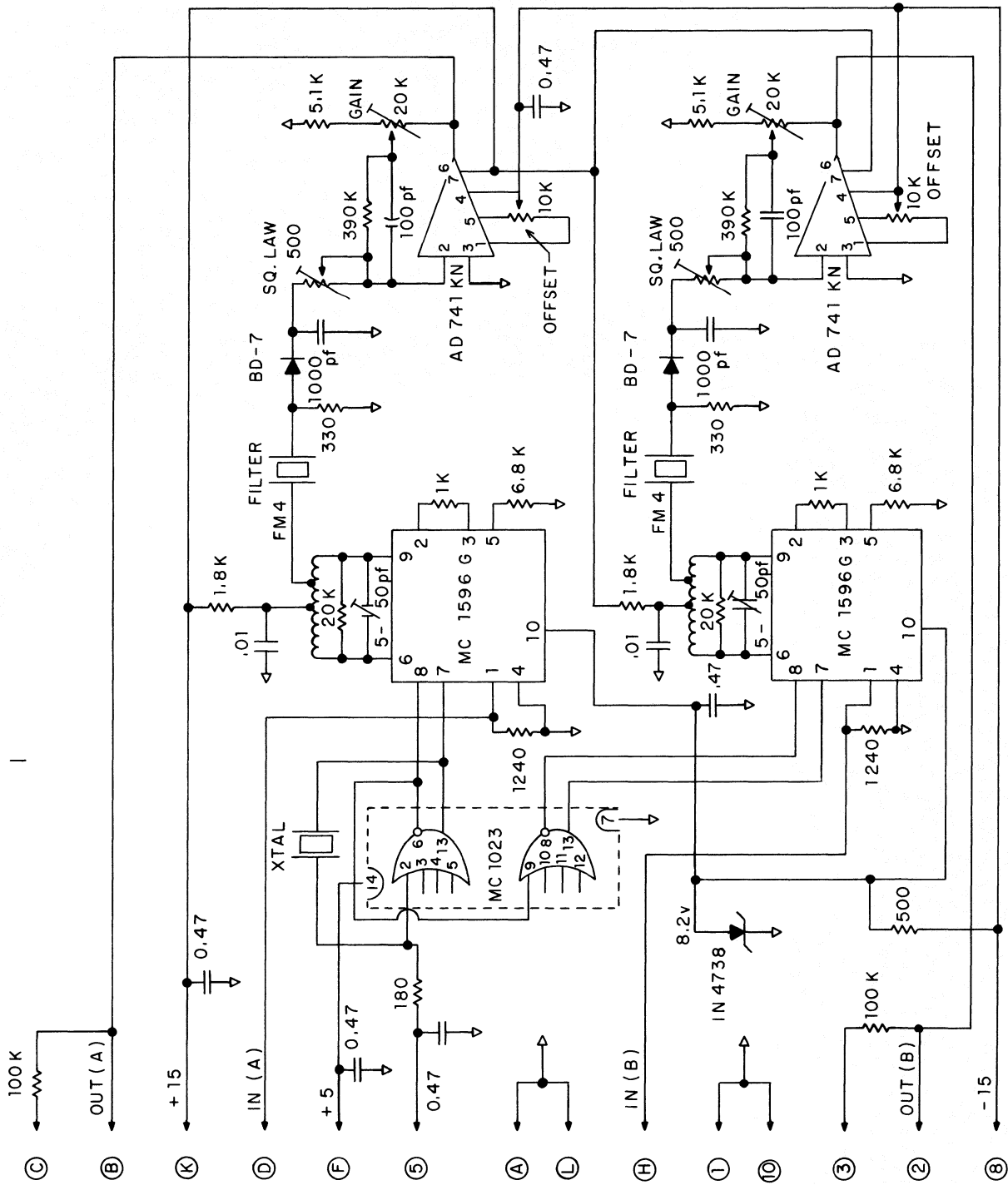

FIGURE 2



DUAL FILTER CIRCUIT BOARD
FIG. 3

Vertical Scale \propto power. Horizontal 200 kHz/cm.

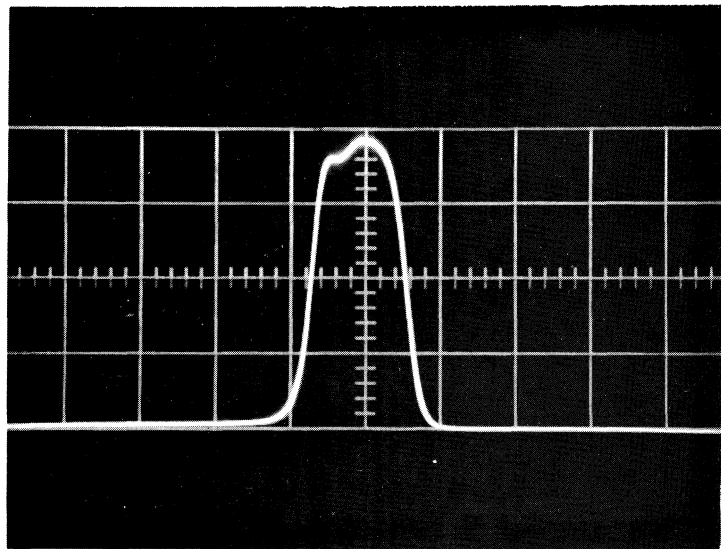
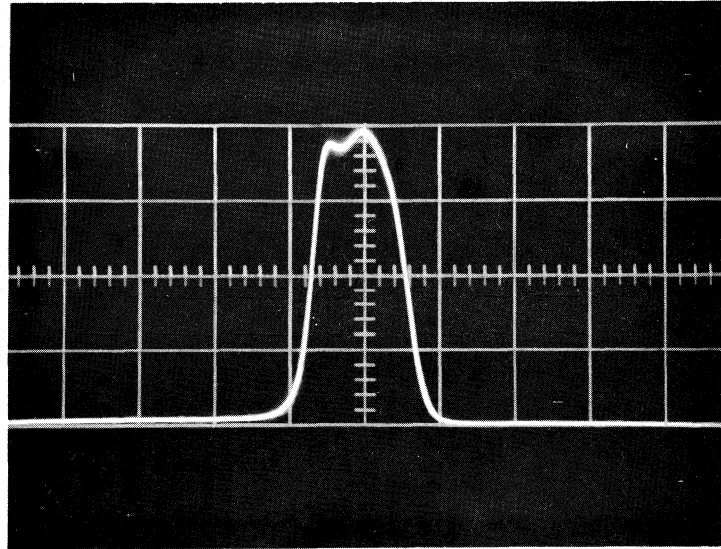
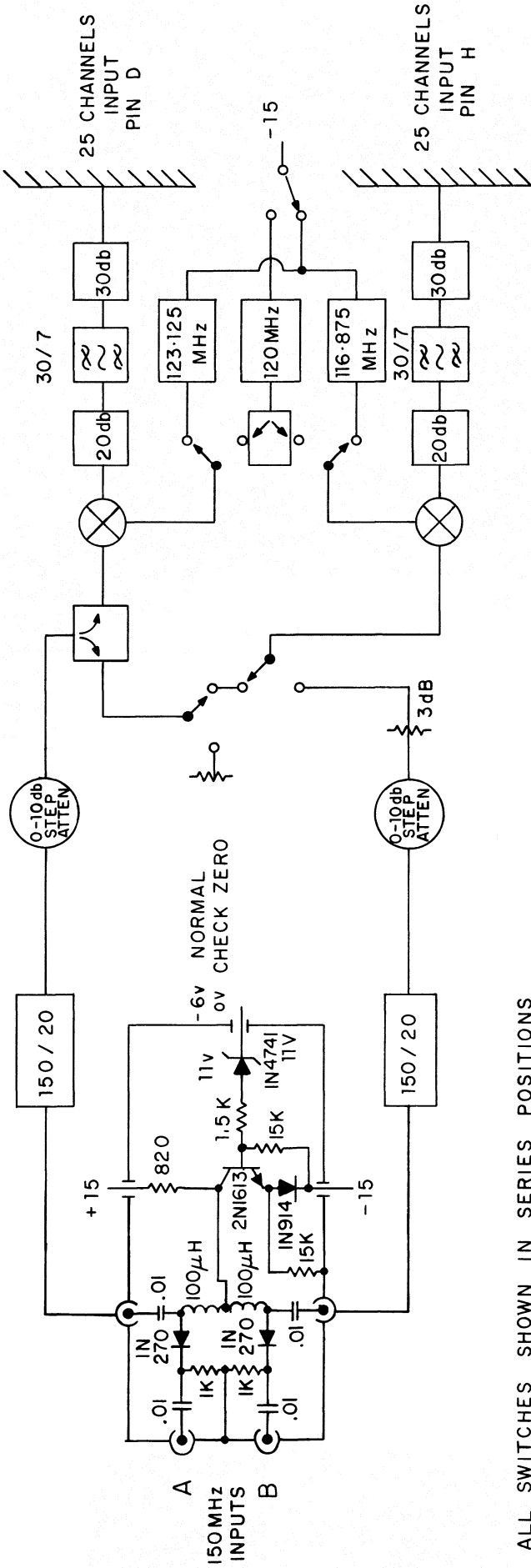

FIGURE 4 - Bandpass of a Pair of Filters.



ALL SWITCHES SHOWN IN SERIES POSITIONS

METER SWITCH

- POSITION 1 CHANNEL TP 2v FSD
- 2 CHANNEL TP 10v FSD
- 3 POWER SUPPLY +5v
- 4 POWER SUPPLY +15v
- 5 POWER SUPPLY -15v
- 6 POWER SUPPLY -22v

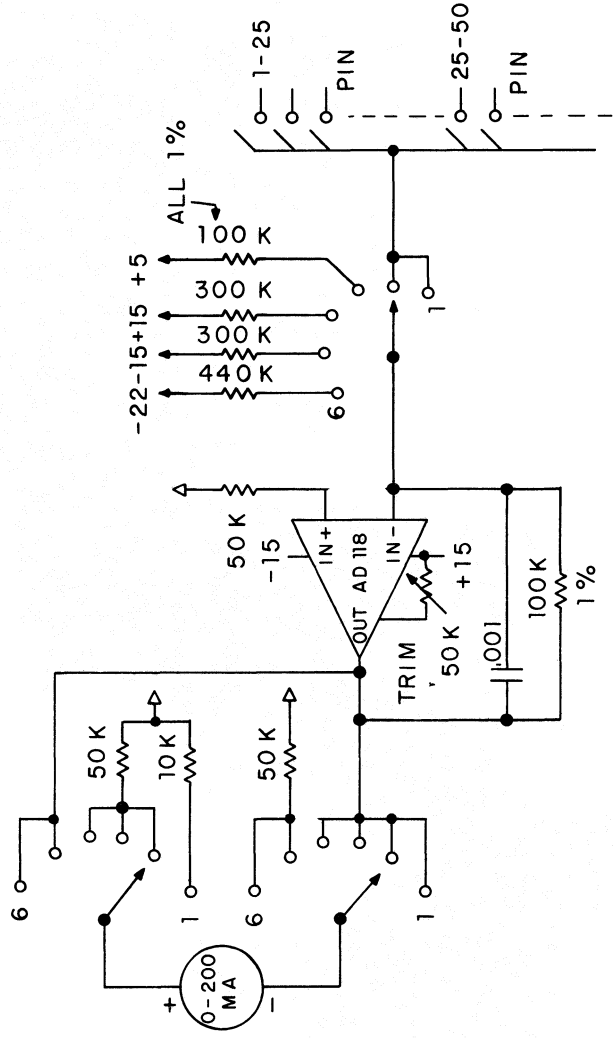

BLOCK DIAGRAM DUAL CHANNEL
250 KHZ FILTER RECEIVER

FIG. 5

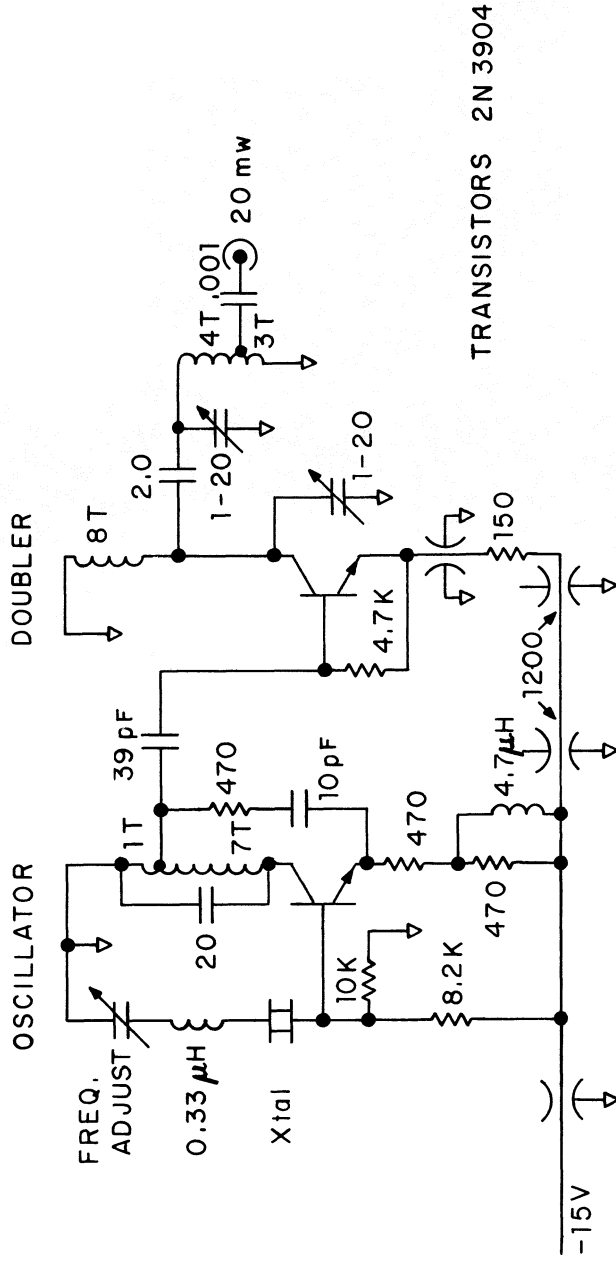

MODE	Xtal FREQ. MHZ	OUTPUT MHZ
PARALLEL	60,000	120,000
SERIES {	61,5625	123,125
	58,4375	116,875

CIRCUIT OF FIRST LOCAL OSCILLATOR

FIG. 6

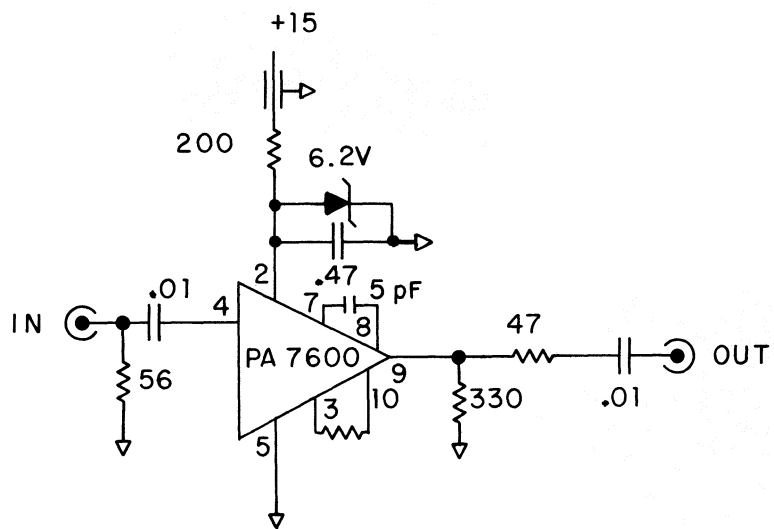

10 - 100 MHz RF AMPLIFIER
GAIN 20 dB

CIRCUIT DIAGRAM OF 30 MHz IF AMPLIFIER
FIG. 7

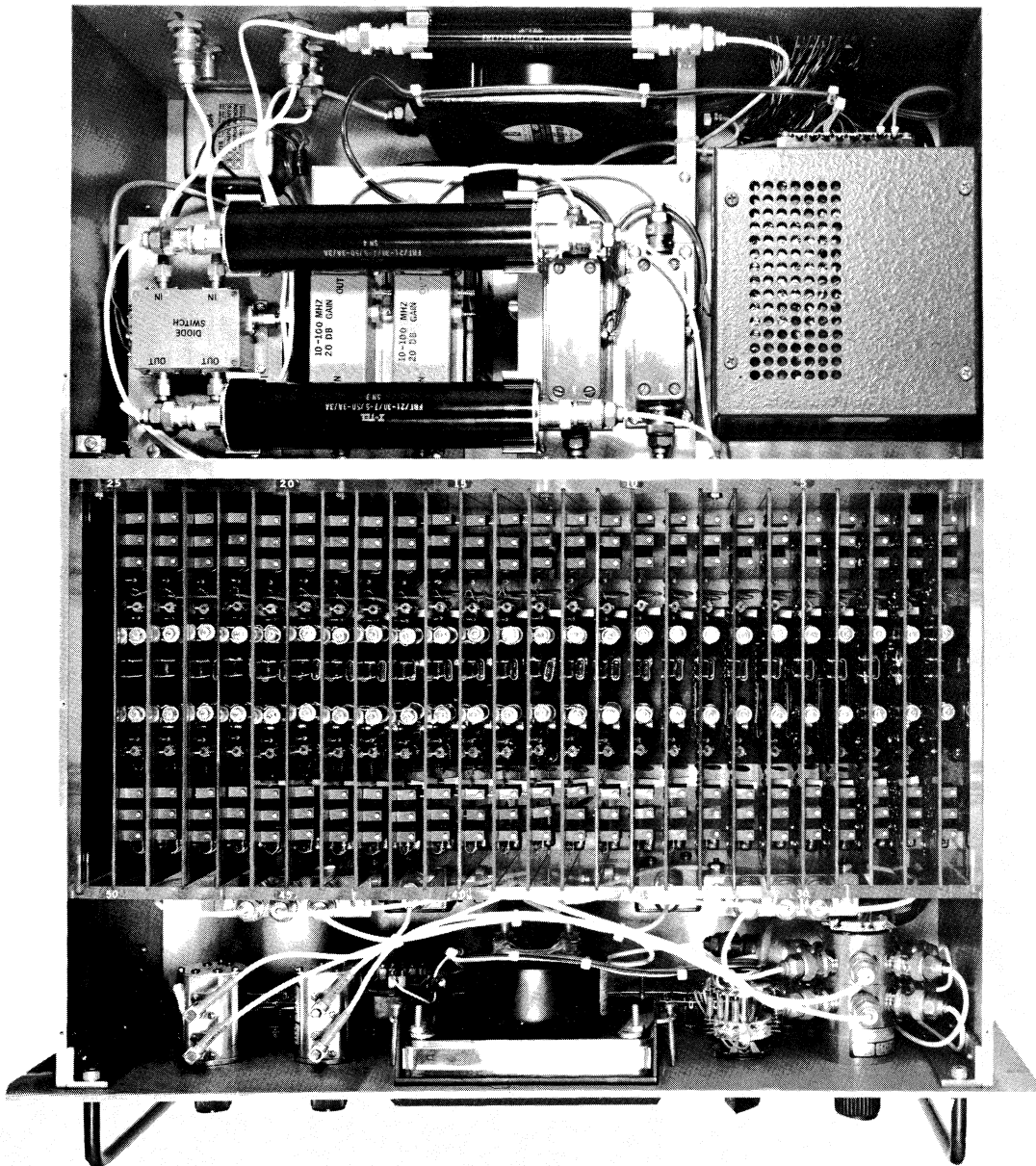
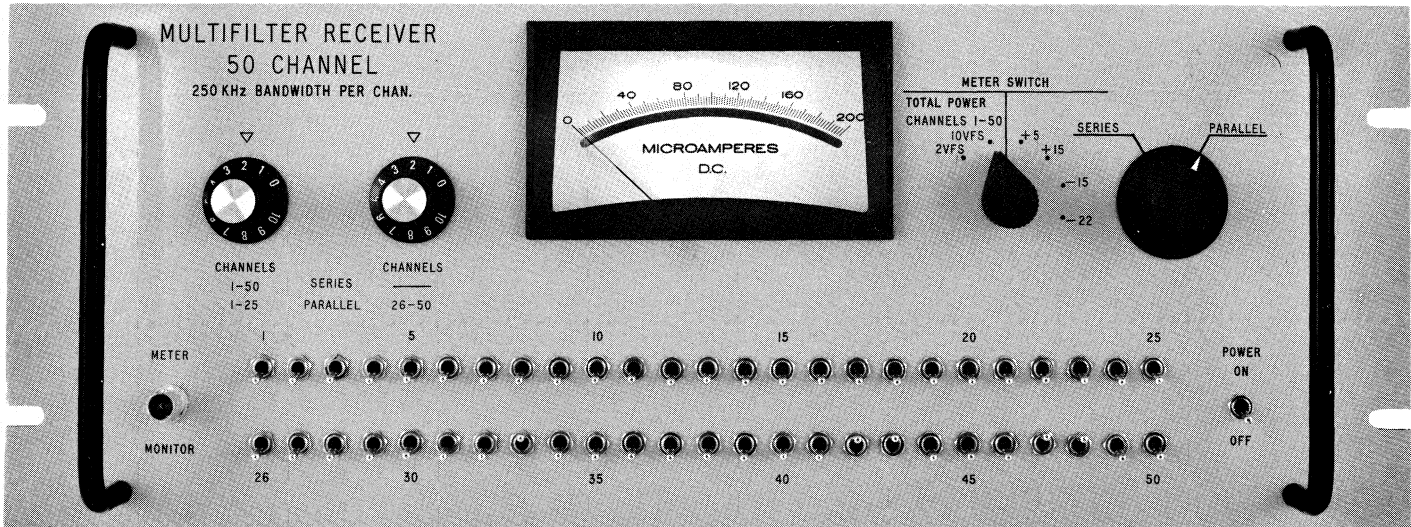

FIGURE 8 — FRONT PANEL AND TOP VIEW OF RECEIVER