

NATIONAL RADIO ASTRONOMY OBSERVATORY
Green Bank, West Virginia

Electronics Division Internal Report No. 108

11 CM, 3-FEED RECEIVER

Richard Fleming

OCTOBER 1971

NUMBER OF COPIES: 150

11 CM, 3-FEED RECEIVER

TABLE OF CONTENTS

		<u>Page</u>
1.0	Introduction	1
2.0	Description of System	1
3.0	Feed Specifications	2
4.0	RF Assembly	2
4.1	Parametric Amplifier Specifications	2
4.2	Mixer-Preamp Specifications	3
4.3	IF Post-Amplifier Specifications	3
4.4	Miscellaneous Component Specifications	3
5.0	LO/Pump Frequency Assembly	5
5.1	LO/Pump Frequency Source Specifications	5
5.2	LO Frequency Path Components	5
5.3	Pump Frequency Path Components	6
6.0	Noise Calibration and Injection Assembly	7
7.0	Circuitry	
7.1	Paramp Control	12
7.2	Noise Diode Driver	13
7.3	Noise Injection Driver	13
7.4	Mixer/Preamp Xtal Monitor Circuitry	14

LIST OF FIGURES

<u>Figure</u>		
1	System Block Diagram	8
2	RF Assembly	9
3	LO/Pump Frequency Assembly	9
4	Noise Calibration and Injection Assembly	10
5	Center Feed Configuration	11
6	Outboard Feeds Configuration	11
7	Bias and Pump Leveling Circuit	12
8	Noise Diode Driver	13
9	Noise Injection Driver	13
10	Mixer/Preamp Xtal Monitor Circuit	14
11	Photo of Front-End Control Rack	15
12	Lower South Side of Box	16
13	Lower North Side of Box	17
14	Top North Side of Box	17
15	Feed End of Box	18
16	Feed E-Vector Position Angles on Sky	18
17	Feed Circular Polarizer Sections	19

11 CM, 3-FEED RECEIVER

Richard Fleming

1.0 Introduction

This report describes the 3-feed, 11 cm receiver that is used on the 300' telescope at Green Bank. Photographs, block diagrams and a brief description of each assembly are included along with general specifications on most components in the system.

2.0 Description of System

The receiver consists of three dual-polarized, S-band feed horns connected to four independent receivers. Two receivers (1 and 2) are connected to the center on-axis feed, one to each polarization, while the other two receivers (3 and 4) are connected to each of the other two feeds. Figure 1 shows the feed configuration and corresponding receivers. Figure 16 shows the feed E-vector position angles.

As seen in Figures 5 and 6, the receivers can be load switched (Dicke switched) or switched between the two polarizations available from each feed. Selection of the load or polarization switching mode on any feed is done from the control room along with noise injection available to offset the unbalance present due to unequal losses in the two switched paths when polarization switching. The noise injection can be modulated synchronously with the polarization switching rate and can be turned on or off from the control room.

The specifications of the receivers are given below:

Center Frequency:	2695 MHz
RF -3 dB Frequencies (DSB):	2575-2815 MHz
IF Bandwidth (-3 dB) (SSB):	5-55 MHz
Noise Temperature (T_R):	115 °K
Calibration Value:	4 °K
Three Feeds:	Dual linear or circular
IF Outputs:	4 independent
HPBW:	5' arc

3.0 Feed Specifications

The feed horns for the 3-feed, 11 cm system were manufactured by Radiation Systems, Inc. , to the following specifications:

General: Three dual-polarized S-band feed horns, in line, with one on axis and at the focal point while the other two as close as possible in angular separation.

Polarization: Either dual-linear or dual-circular polarization, selected by mechanical change performed on feeds.

Frequency Range: 2650 to 2750 MHz.

VSWR: < 1.25:1.

Cross Polarization: The opposite sense polarization must be rejected by > 17 dB in the central 60° of the feed pattern.
(Axial Ratio = 2.48 dB.)

Spillover: < 5%.

Aperture Efficiency: > 65% assuming a perfect reflector.

Resistive Losses: < 0.1 dB.

Pressurization: Capable of up to 3 p. s. i.

Physical Configuration: See Figure 1.

4.0 RF Assembly

The RF assembly consists of all components between the feeds and the output from the IF post-amplifier. There are four complete and virtually identical RF assemblies in this system and the components and their specifications are listed in the following sections of this report. The components are rigidly mounted to a solid plate. This is to eliminate any mechanical stresses being applied to the paramp which in turn would cause a gain change due to the physical nature of these particular paramps.

4.1 Parametric Amplifier Specifications

The system uses four AIL type 1784-00 degenerate parametric amplifiers, one for each channel.

<u>Center Frequency:</u>	2695 MHz
<u>Instantaneous Bandwidth:</u>	80 MHz (3 dB)
<u>Double-Sideband Gain:</u>	18 dB
<u>Noise Temperature:</u>	60 °K
<u>Input/Output VSWR:</u>	< 1.25:1
<u>Pump Frequency/Power:</u>	5390 MHz/10 mW

4.2 Mixer-Preamp Specifications

Model MMP2-4AA76 low-noise mixer-preamps manufactured by RHG, to the following specifications, are used in the system:

<u>RF/LO Input Frequency:</u>	2600 to 2800 MHz
<u>IF Center Frequency:</u>	27.5 MHz
<u>IF Bandwidth:</u>	55 MHz
<u>Noise Figure:</u>	< 5.0 dB (DSB)
<u>RF to IF Gain:</u>	31 dB
<u>Power Required:</u>	+15 V DC at 20 mA
<u>Crystal Current:</u>	2.5 mA (ext 100 ohm resistor)

4.3 IF Post-Amplifier

A special version of the NRAO WB-2 amplifier built to the following specifications follows each mixer-preamp:

<u>Frequency Range:</u>	4-65 MHz (0.5 dB)
<u>Gain:</u>	23 dB
<u>Output Power:</u>	+4 dBm (1 dB gain compression point)
<u>Input/Output VSWR:</u>	< 2.0:1
<u>Power Required:</u>	+15 V DC at 20 mA

4.4 Miscellaneous Components

The following components and their specifications are also included in the RF assembly:

1. Cross Guide Coupler: MDL WR 284 284XT139
Frequency Range: 2645-2745 MHz

6.0 Noise Calibration and Injection Assembly

Figure 4 shows a block diagram of the noise calibration and noise injection components. The components and their specifications are shown below:

<u>Constant Current Source:</u>	MPD CCM 25-R
Input/Output Voltage:	28/15
Output Current Max. :	25 mA
Regulation:	1.0%
<u>3 dB Hybrid:</u>	Aerotech K-4000
Frequency Range:	2-4 GHz
Isolation:	≥ 25 dB
VSWR:	≤ 1.2:1
<u>Noise Diode:</u>	MSC MC 7027
Frequency:	2700 MHz ± 100 MHz BW
Output:	35.2 dB TEX
Power Required:	+15 V DC
<u>Variable Attenuator:</u>	Merrimac AUM 15A
Frequency Range:	2-8 GHz
Attenuation Range:	0-15 dB
VSWR:	≤ 1.5:1
Adjustment:	Mechanical screw
<u>Attenuators:</u>	FXR AG-03F, 06F, 10F
Frequency:	DC - 7 GHz
Attenuation Value:	3, 6, 10 dB
VSWR:	DC - 5 GHz, < 1.25:1
<u>Directional Coupler:</u>	Narda 4013-10
Frequency Range:	2.0-4.0 GHz
Coupling:	10 dB
Directivity:	> 20 dB
MA VSWR:	< 1.15:1
SA VSWR:	< 1.20:1

6.0 Noise Calibration and Injection Assembly

Figure 4 shows a block diagram of the noise calibration and noise injection components. The components and their specifications are shown below:

<u>Constant Current Source:</u>	MPD CCM 25-R
Input/Output Voltage:	28/15
Output Current Max. :	25 mA
Regulation:	1.0%
<u>3 dB Hybrid:</u>	Aerotech K-4000
Frequency Range:	2-4 GHz
Isolation:	≥ 25 dB
VSWR:	≤ 1.2:1
<u>Noise Diode:</u>	MSC MC 7027
Frequency:	2700 MHz ± 100 MHz BW
Output:	35.2 dB TEX
Power Required:	+15 V DC
<u>Variable Attenuator:</u>	Merrimac AUM 15A
Frequency Range:	2-8 GHz
Attenuation Range:	0-15 dB
VSWR:	≤ 1.5:1
Adjustment:	Mechanical screw
<u>Attenuators:</u>	FXR AG-03F, 06F, 10F
Frequency:	DC - 7 GHz
Attenuation Value:	3, 6, 10 dB
VSWR:	DC - 5 GHz, < 1.25:1
<u>Directional Coupler:</u>	Narda 4013-10
Frequency Range:	2.0-4.0 GHz
Coupling:	10 dB
Directivity:	> 20 dB
MA VSWR:	< 1.15:1
SA VSWR:	< 1.20:1

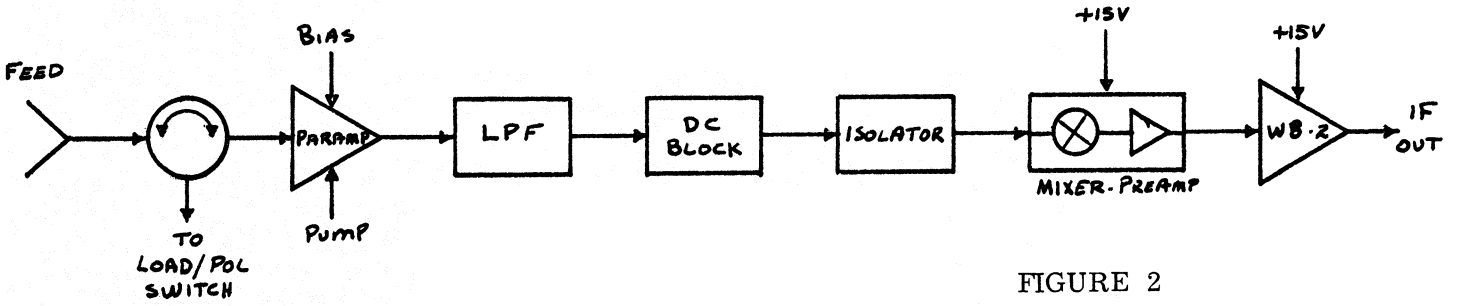

FIGURE 2
RF ASSEMBLY

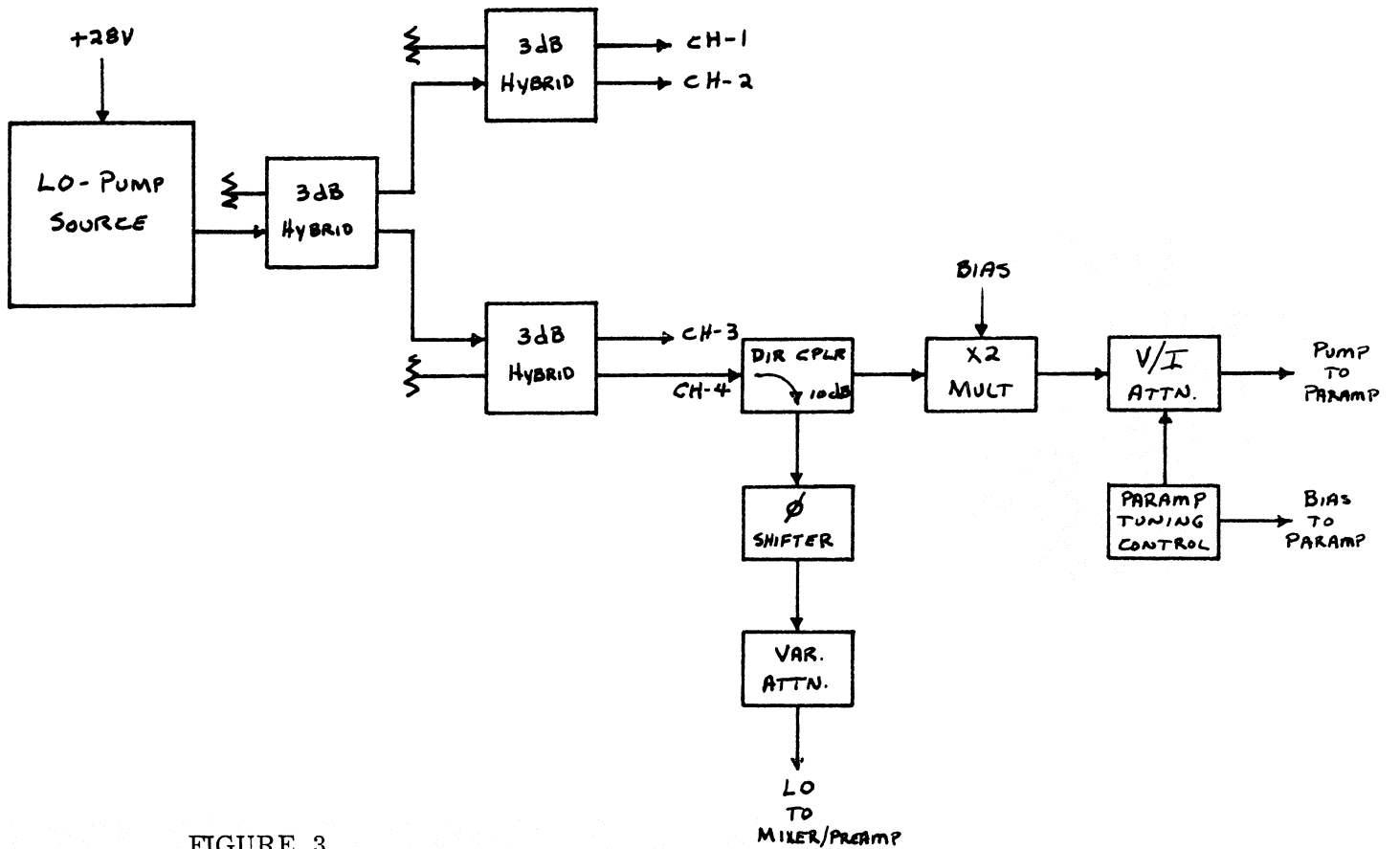

FIGURE 3

LO/PUMP FREQUENCY ASSEMBLY

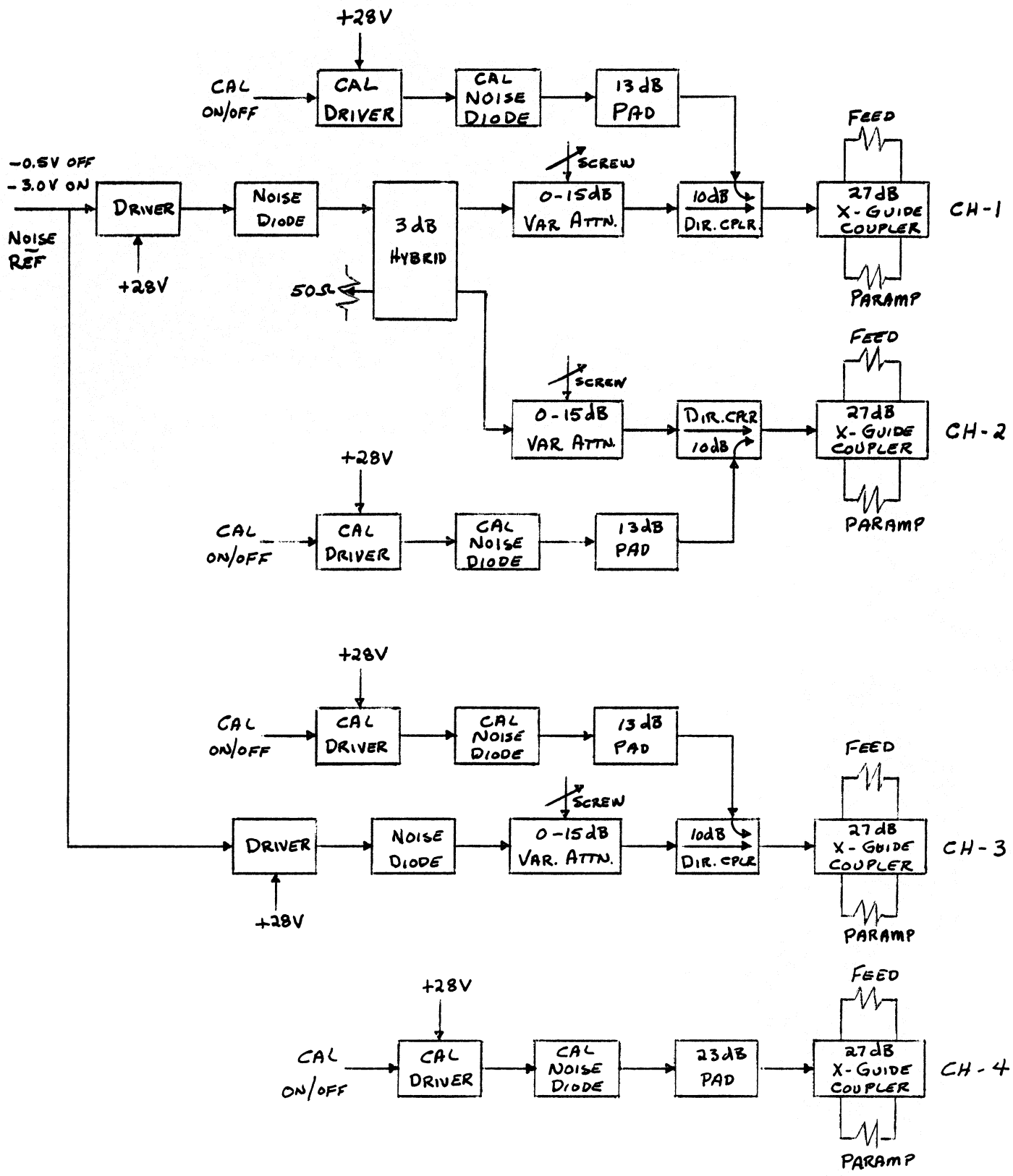

FIGURE 4

NOISE CALIBRATION AND INJECTION ASSEMBLY

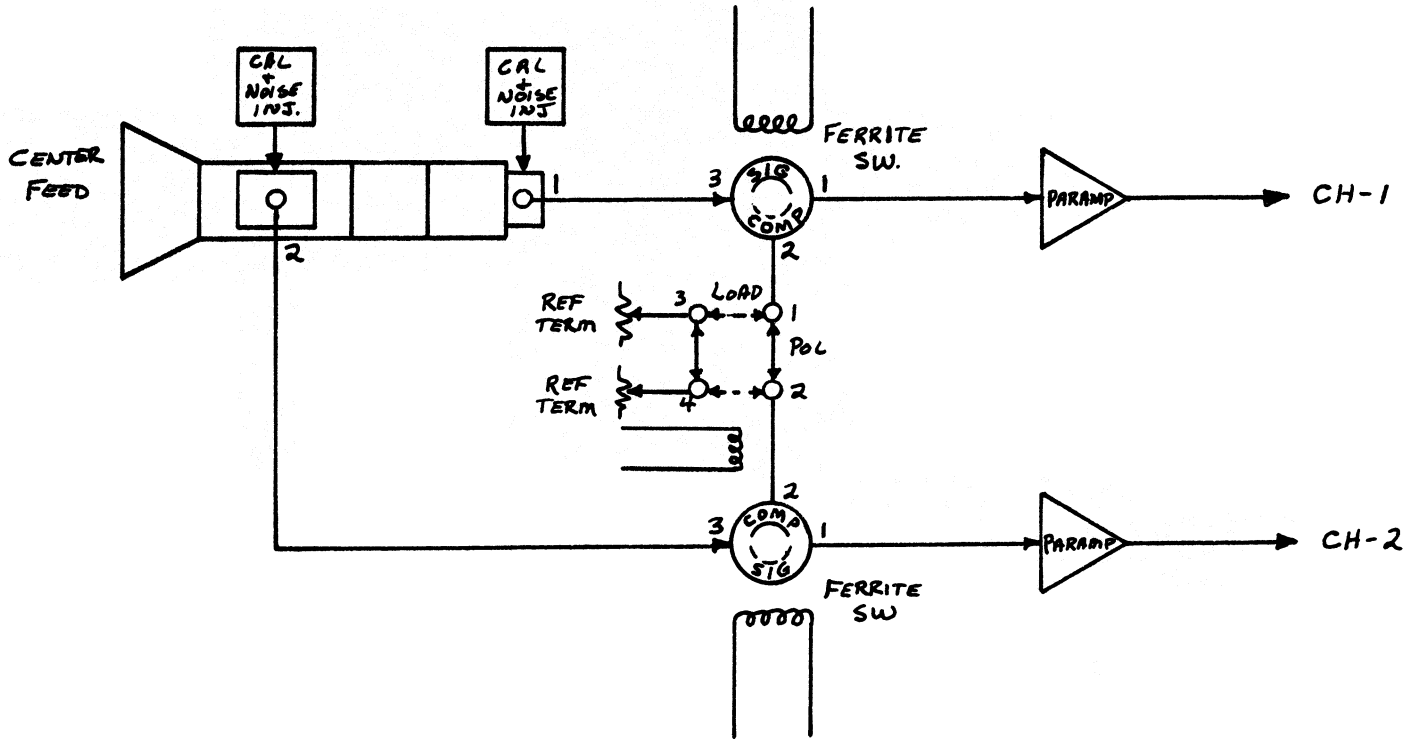

FIGURE 5 - CENTER FEED CONFIGURATION

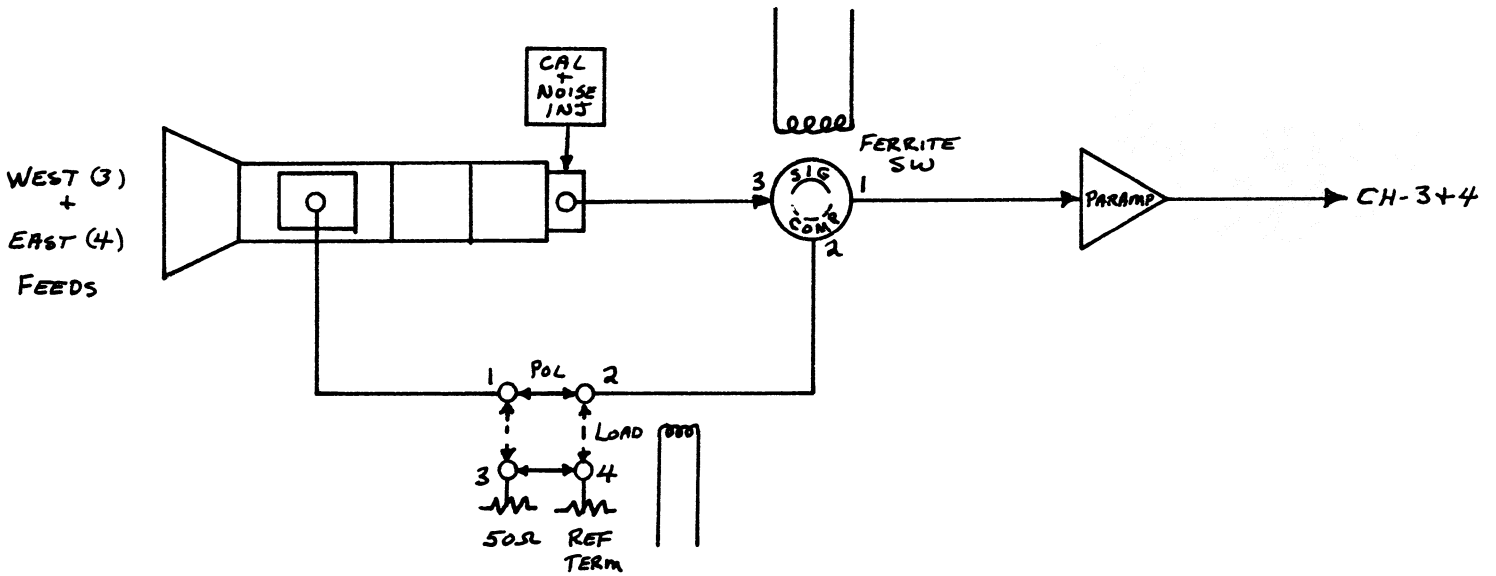

FIGURE 6 - OUTBOARD FEEDS CONFIGURATION

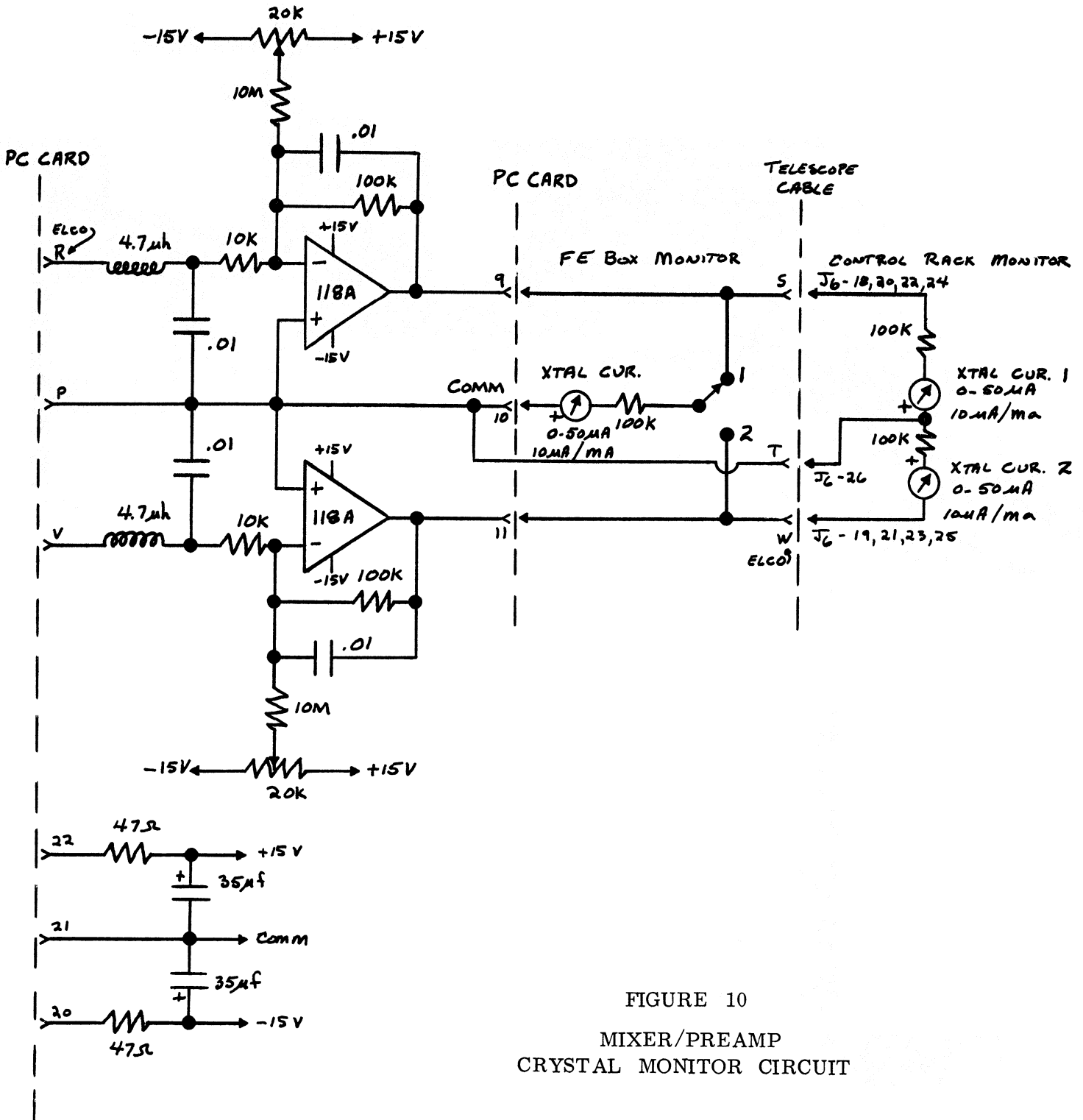

FIGURE 10
MIXER/PREAMP
CRYSTAL MONITOR CIRCUIT

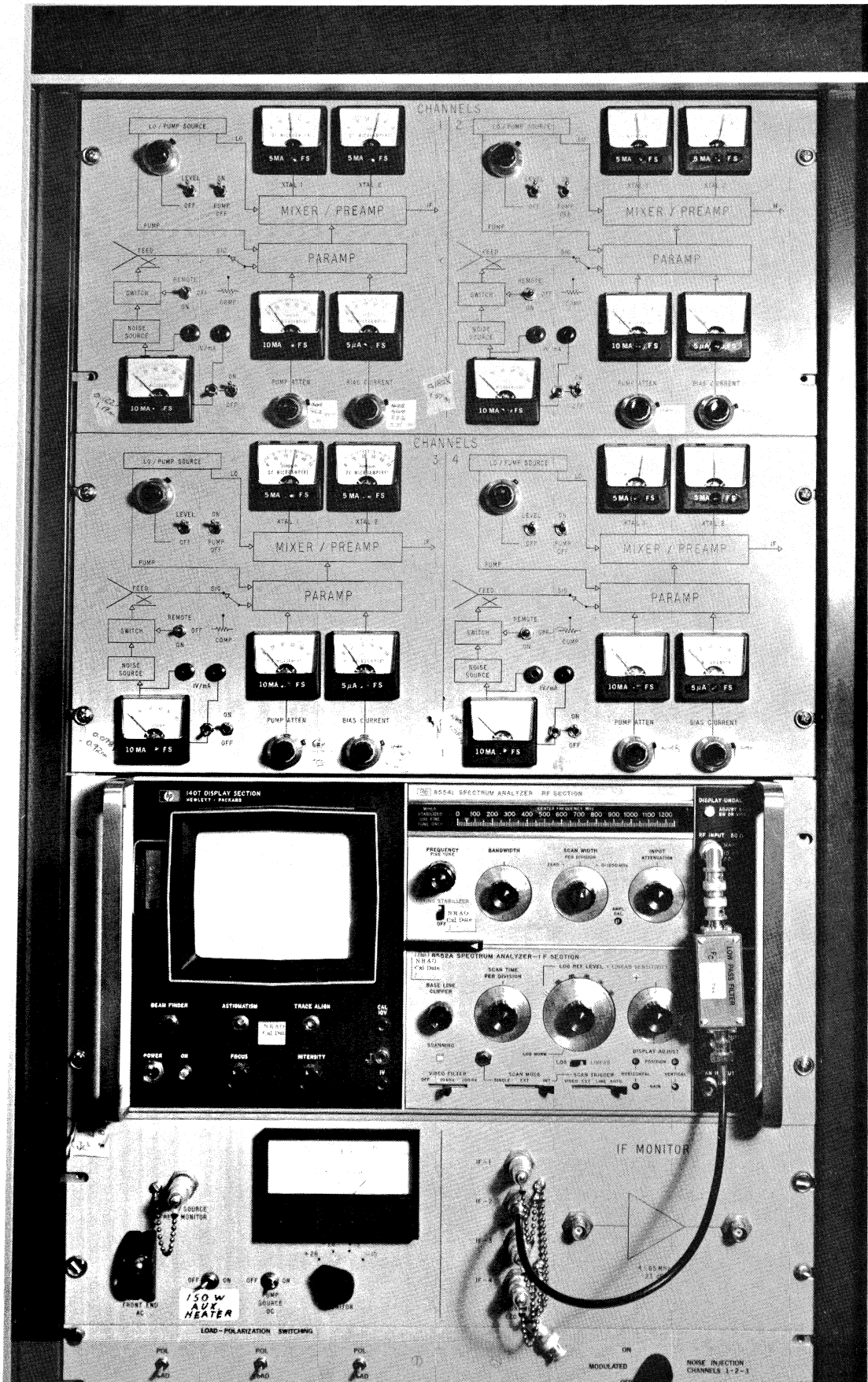

FIGURE 11

FRONT-END CONTROL RACK

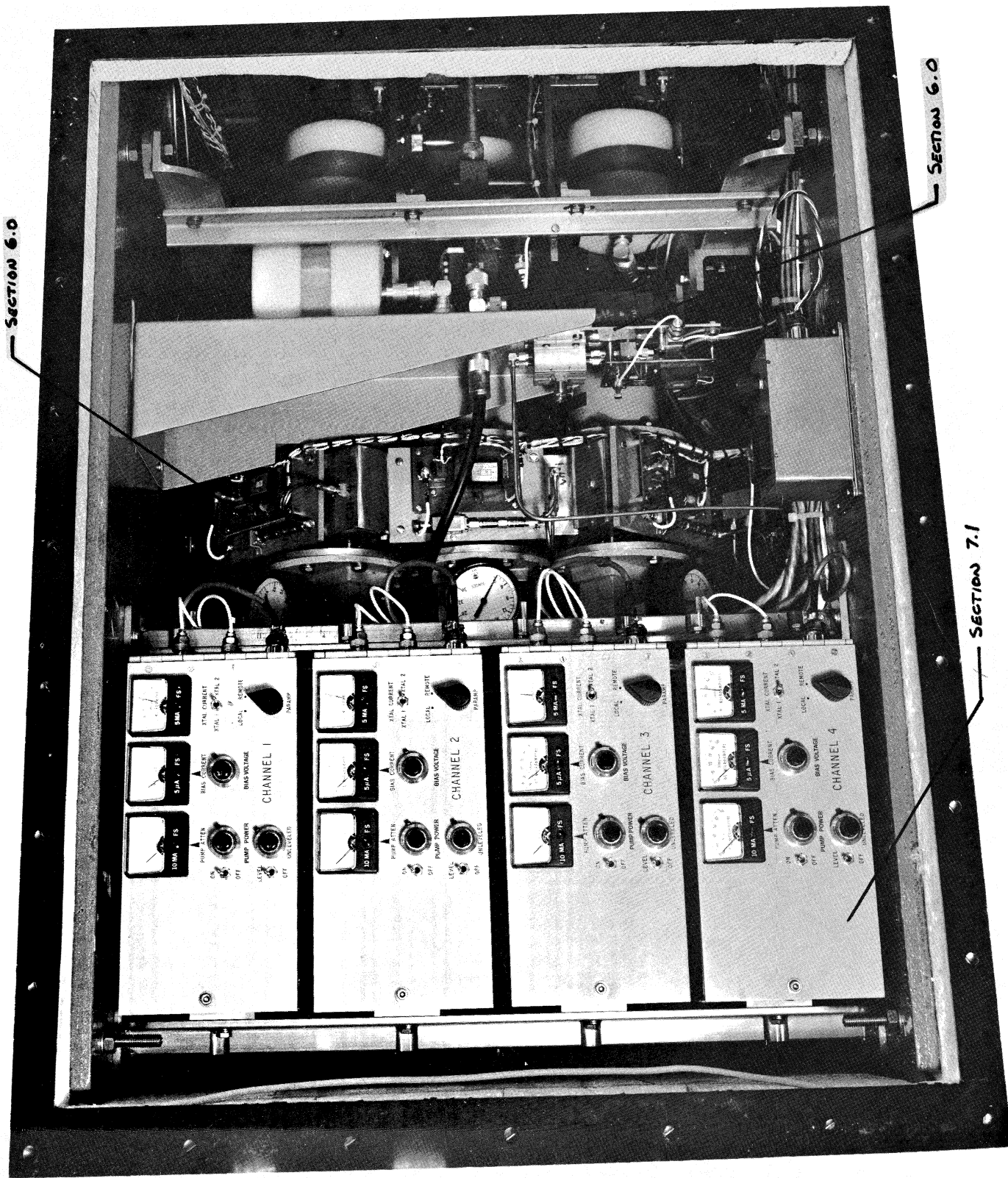

FIGURE 12

LOWER SOUTH SIDE OF BOX

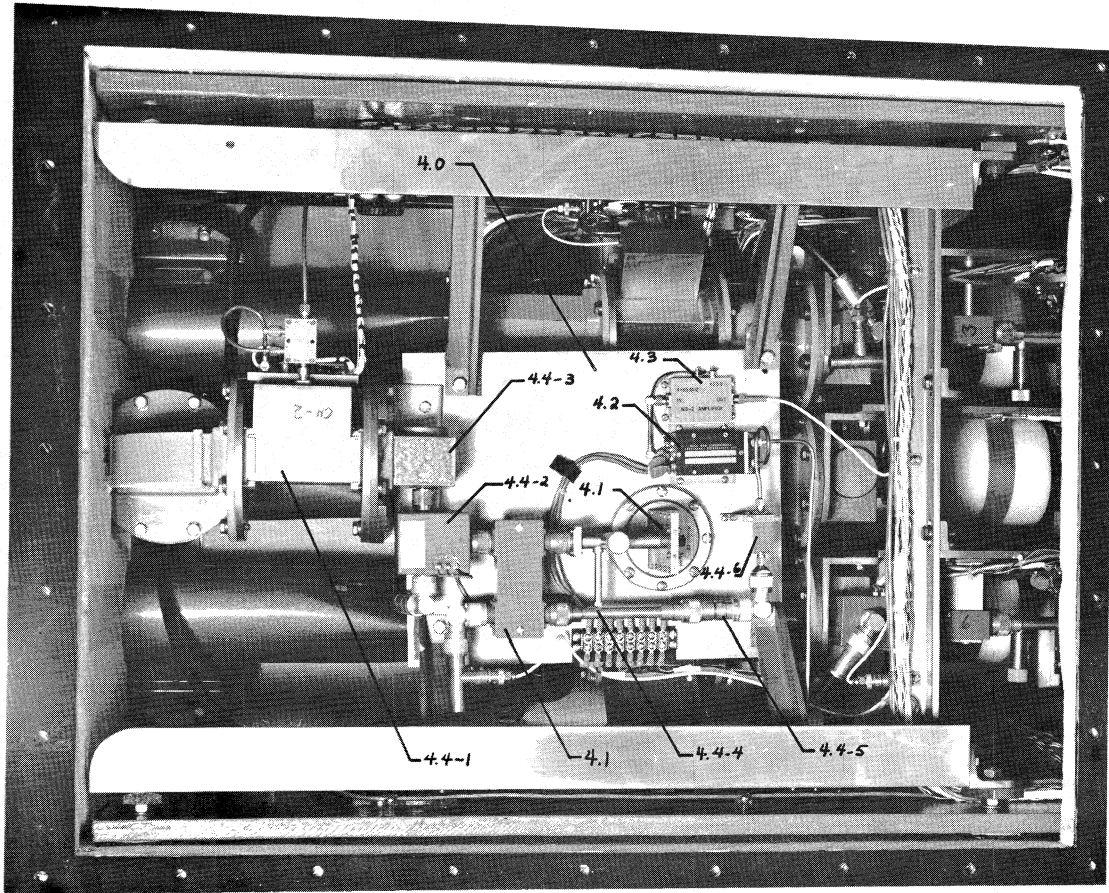

FIGURE 13
LOWER NORTH SIDE OF BOX

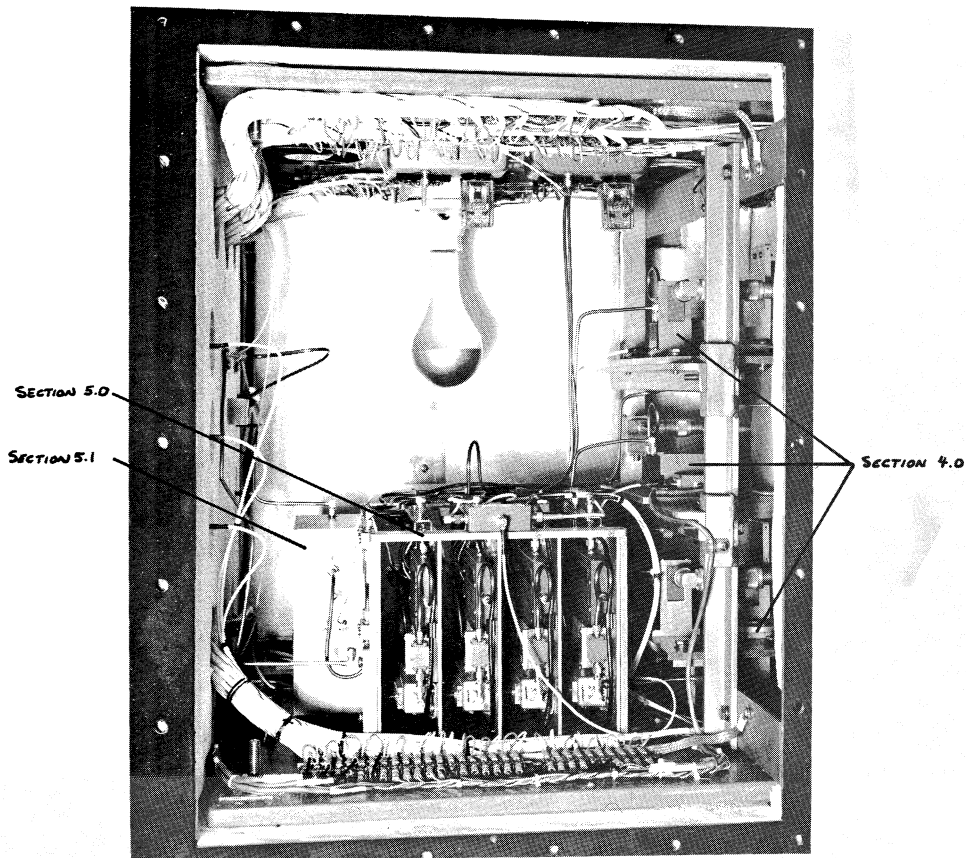

FIGURE 14
TOP NORTH SIDE OF BOX

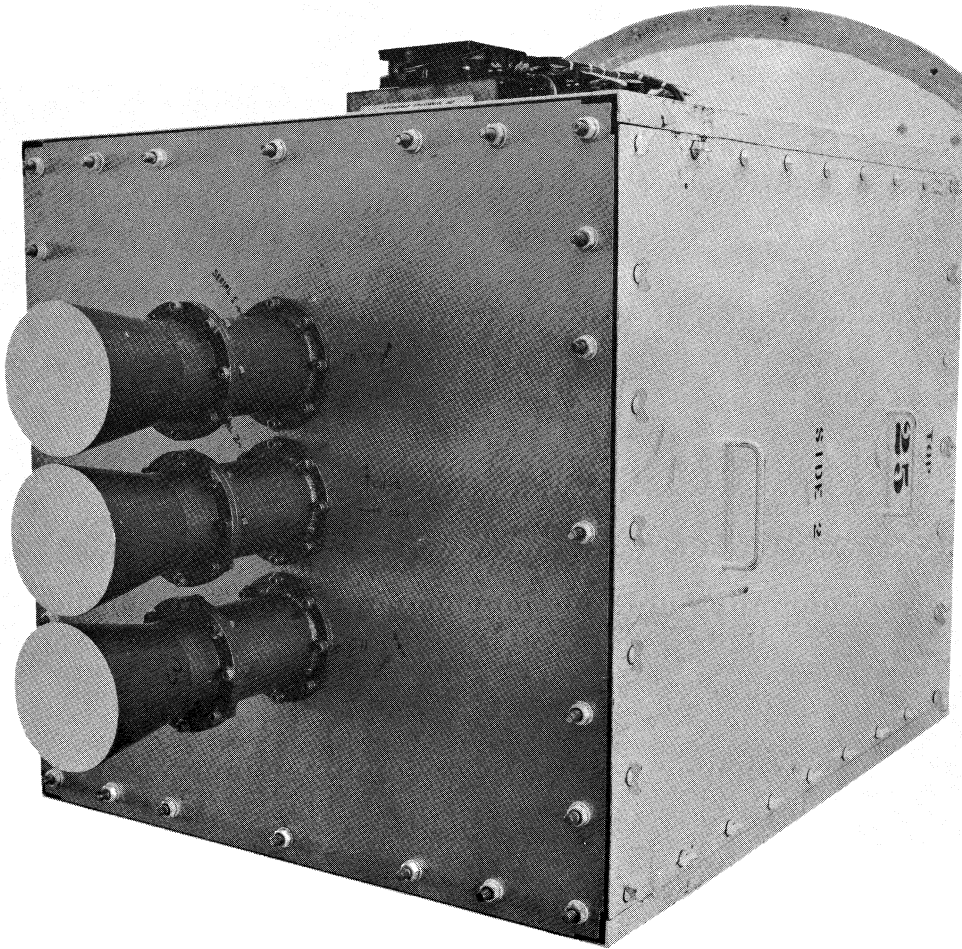

FIGURE 15
FEED END OF BOX

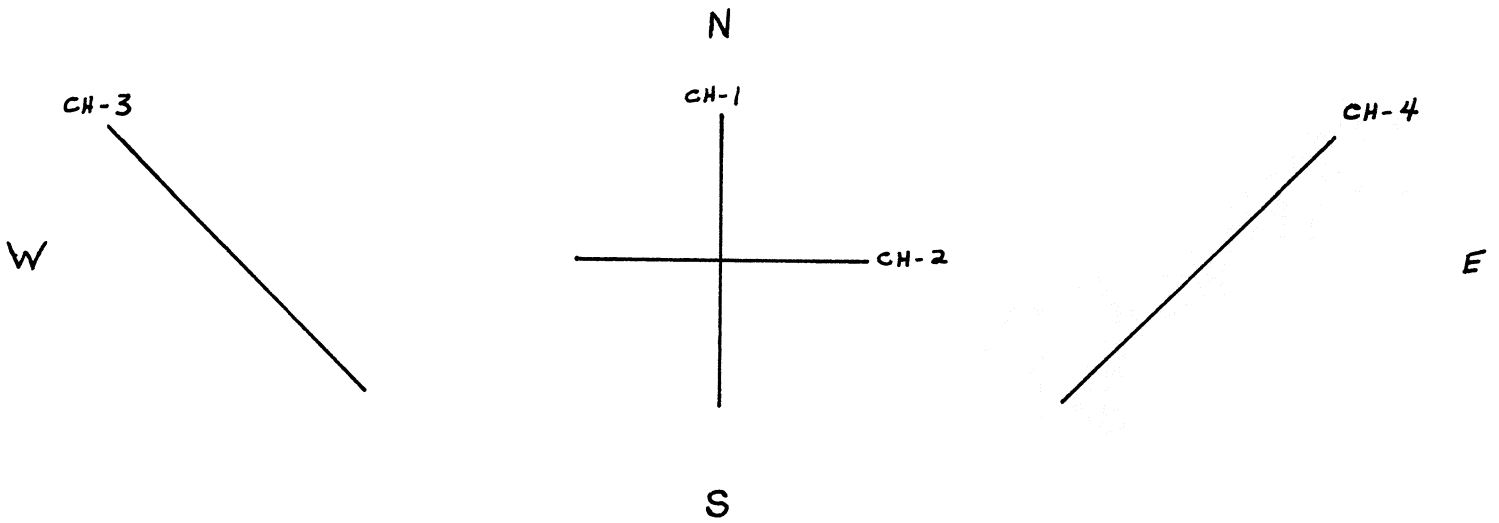

FIGURE 16
FEED E-VECTOR POSITION ANGLES ON SKY

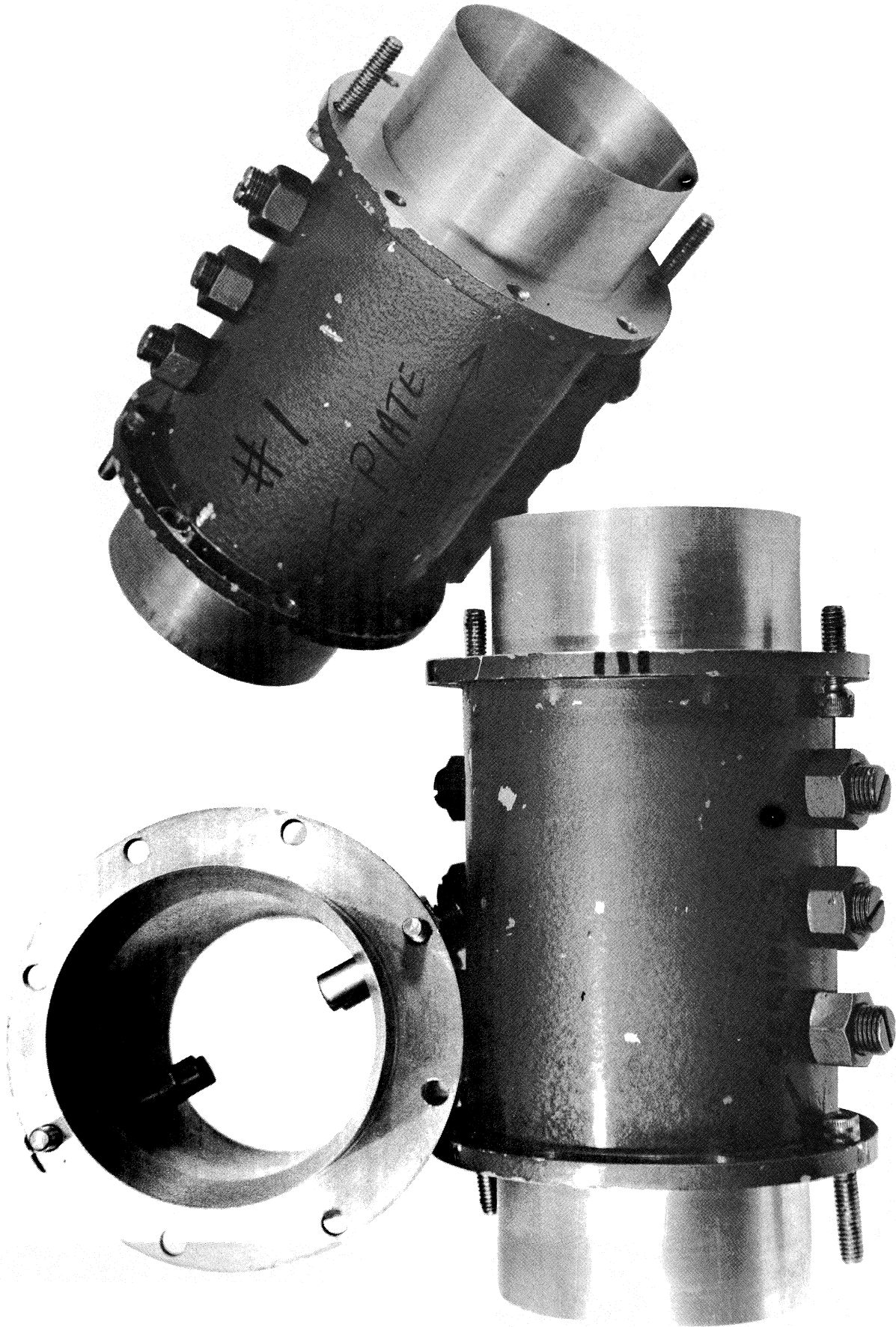

FIGURE 17
FEED CIRCULAR POLARIZER SECTIONS