

NATIONAL RADIO ASTRONOMY OBSERVATORY
Green Bank, West Virginia

Electronics Division Internal Report No. 105

CHARACTERIZATION TESTS OF THE
WESTERN ELECTRIC PARAMETRIC AMPLIFIER

Dennis Sweeney

SEPTEMBER 1971

NUMBER OF COPIES: 150

CHARACTERIZATION TESTS OF THE WESTERN ELECTRIC PARAMETRIC AMPLIFIER

Dennis Sweeney

Introduction

The purpose of this report is to describe the results of tests run on some surplus Western Electric parametric amplifiers obtained from Stirling Colgate.

The parametric amplifier unit contains several other circuits in addition to the paramp itself. See Figure 1. The RF protector strip is a PIN diode limiter; it is of little value since its action is initiated by incident power. The limiter is DC isolated from the input and there is a DC path from the input (J1) to the switch input (J3). There is also a directional coupler in the protector strip for the injection of a test signal. There is a phase equalizer which forms one wall of the amplifier enclosure. It consists of a number of phase shifters and it appears to be of no value. The transistor amplifier was tested and the results will be presented later.

Operation

In order to use the paramp it is only necessary to apply bias and pump power. It would also be desirable to remove the paramp from its rather large and heavy original assembly. A word of warning about disassembly: There are quite a number of screws in the strip line, the tension of which may have been used to fine adjust the amplifier. The screws which hold the amplifier assembly together have a dab of reddish-brown paint on them. Avoid loosening any other of the screws.

The paramp requires +14 V DC at about 3 milliamps for varactor bias. This can be applied directly to the bias box or to pin A of the DC input connector. Pin C is ground. Pins B and D have nothing connected to them. The bias circuit is shown in Figure 2A. The paramp also requires about 100 mW of pump power at 11.1 GHz. The pump input is WR-90 type waveguide. The pump source used for testing is shown in Figure 2B.

Performance

The several units tested here worked immediately upon application of bias and pump power. All that was necessary was to adjust the pump power for best gain flatness. Table 1 shows the test results and some other pertinent application data.

TABLE 1

Bandwidth -3 dB	1460 MHz 1090 MHz
		-1 dB 1110 MHz 1440 MHz
Gain		16.5 dB
Gain Flatness		< .2 dB
Noise Temperature (see note in text)		110 °K
Pump Frequency		11.1 GHz
Pump Power		67 mW
Change in Gain vs. Pump Power		15: 1
Change in Gain vs. Pump Frequency		3.5 dB/5 MHz
Bias Voltage	Input 641 mV
		Output 332 mV
Bias Current	Input23 μ A
		Output45 μ A
Isolation — Noise Out vs. Source Impedance		< .1 dB
Gain per Stage	Input Stage 8.5 dB
		Output Stage 8.0 dB

Gain and bandwidth were measured by normal swept frequency techniques. Higher gain can be obtained by increasing pump power and readjusting the bias. (Pump power has a marked effect on passband flatness; more on this later.) Increasing gain in this manner produces a dip in the center of the passband response. This effect is much more pronounced than that of decreasing bandwidth with increasing gain. Table 2 shows the effects of such tuning.

TABLE 2

Gain	18.5 dB
Bandwidth (-3 dB)	1100 MHz 1460 MHz
Gain Flatness	1 dB
Bias	Input 737 mV Output 419 mV

Individual stages could be tuned for higher gain. The input stage could be tuned for a maximum of 11 dB, and the output stage produced a maximum of 12 dB of gain. Together they produced a gain of 24.5 dB and a bandwidth of 1125 MHz and 1435 MHz between -3 dB points. The gain flatness had deteriorated to about 1.5 dB and over 200 mW was required to pump the amplifier, however.

The noise temperature was measured using hot and cold loads and the Y factor method. The figure in Table 1 does not include the second stage contribution. The second stage for the noise temperature tests was a RHG 1-2 GHz mixer-preamp. It had a noise temperature of 457 °K (DSB). The paramp temperature was 120 °K including the second stage. A different amplifier was measured at 110 °K including the second stage contribution. The 150 °K temperature stated by Dr. Colgate would be about right considering the contribution from the 8.5 dB noise figure of the transistor amplifier.

Changes in pump power and frequency do not affect gain uniformly. A .2 dB increase in pump power increased the gain of the high frequency end of the response by about 3 dB and decreased the gain at the low end by 2 dB. Correspondingly, a .2 dB decrease in pump power caused the high end to droop 2 dB while the low frequency end came up by 1 dB. The numbers in Table 1 indicate the worst case conditions. Pump

frequency changes had similar effects. An increase of 5 MHz increased high end response by 3.5 dB and decreased the low end by about 2 dB. A decrease of 5 MHz brought a 1 dB gain increase at the low end and a 3 dB decrease at the high end. Again the table figures represent worst case. If the pump is within ± 10 MHz of 11.1 GHz, there will be little difficulty in adjusting the paramp. As the pump is moved away from 11.1 GHz, in general, more pump power is required. This is particularly true as the pump is moved down in frequency.

The isolation at the input was checked by measuring the change in noise power when going between a 50 ohm termination, an open, and a sliding short. This test was also run using a coax-to-waveguide transition and a waveguide sliding short. This test was to test pump leakage. As the figure in Table 1 indicates, the input isolation is very good.

The paramp was extremely stable mechanically. It showed no tendency toward "touchiness" at all.

Transistor Amplifier

Table 3 shows the characteristics of the transistor amplifier strip:

TABLE 3

Power	+14 V	at	70 mA
Gain	39 dB		
Noise Figure	8.5 dB		
Frequency Response	-1 dB		940 MHz 1465 MHz
	+1.5 dB peak at		1030 MHz
	+1 dB		990 MHz 1070 MHz
	- 3 dB		1590 MHz
			Low was beyond range of sweeper— approximately 900 MHz.
VSWR	Input	$\approx 2:1$	from >900 MHz 1800 MHz
	Output	$\approx 2:1$	from >900 MHz 1680 MHz
Power Out (1 dB compression) ...	0 dBm		

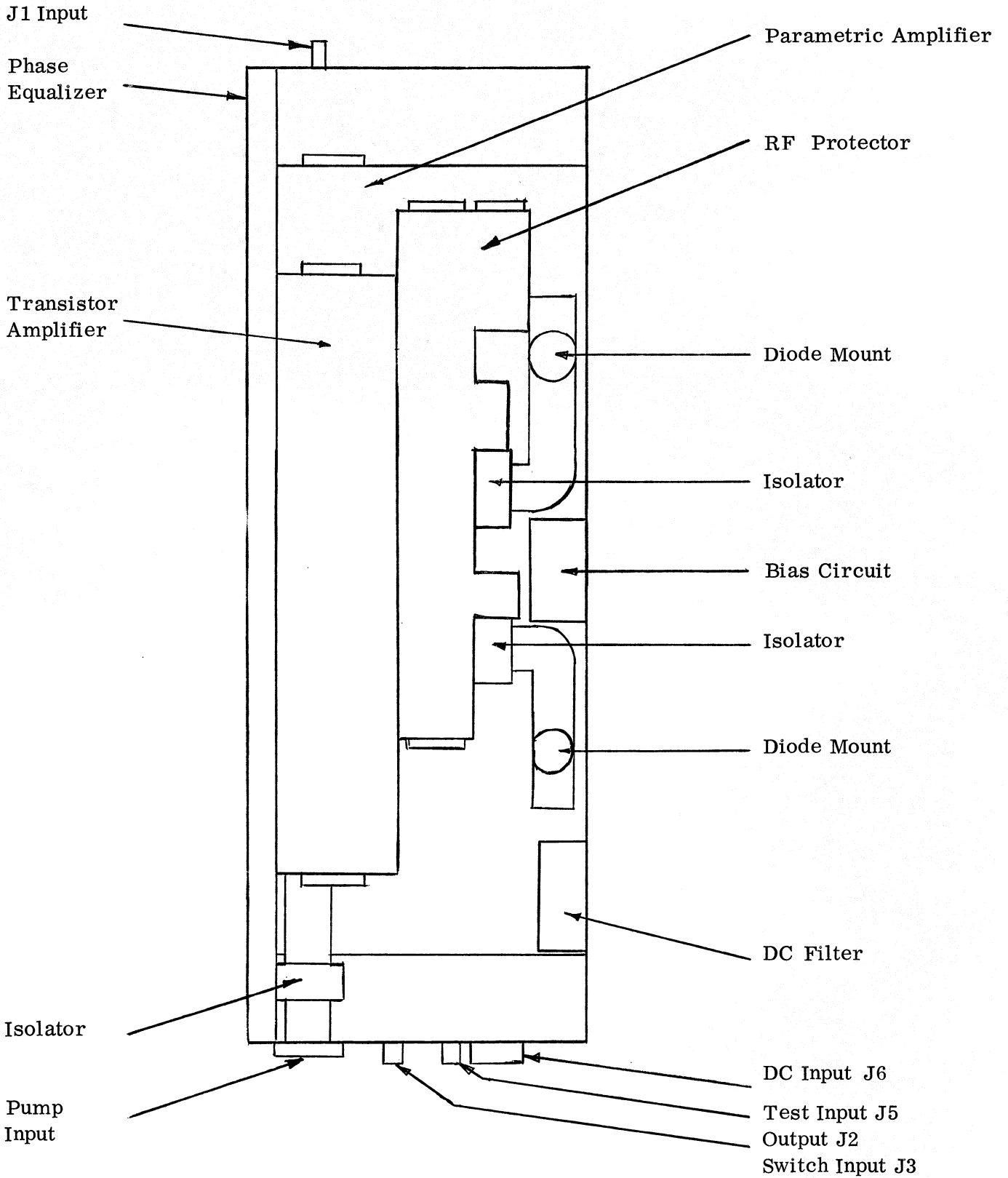

Figure 1 - Parametric Amplifier Unit

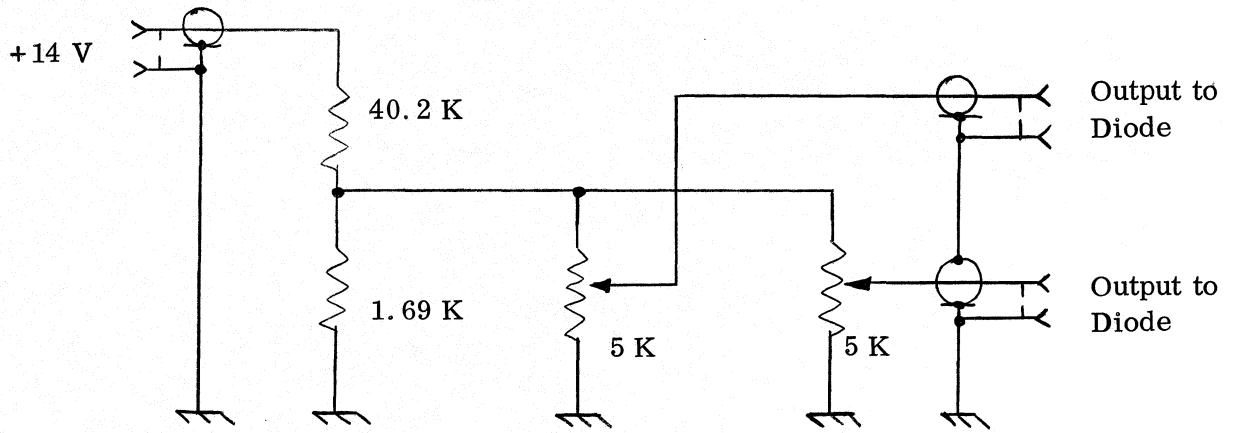

Figure 2A - Bias Circuit

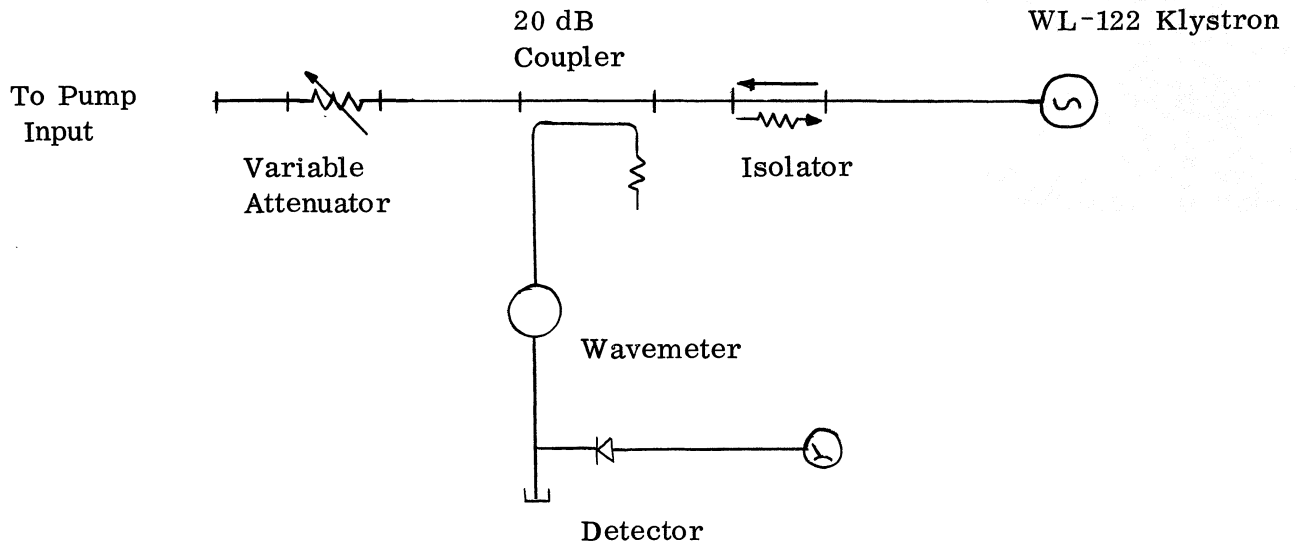

Figure 2B - Pump