

GBT memo

A 10 GHz bandwidth spectrometer for the GBT

Authors: D. Anish Roshi, Paul Demorest, Dale Frail, Scott Ransom

Affiliation: NRAO

Date: Sep 17, 2010, (v0.1)

Abstract

We describe the possibility of using the new GBT spectrometer as a 10 GHz bandwidth spectrometer. The modifications needed in the GBT system to provide the 10 GHz IF signal to the GBT spectrometer are described in the report. The GBT spectrometer is being built by the CICADA collaboration using CASPER technology.

1 Introduction

A new spectrometer for the Green Bank Telescope (GBT) is being built by the CICADA collaboration. This spectrometer project is funded by the NSF ATI program and uses the CASPER technology. The specifications of the spectrometer is given in Roshi et al. (2010). A block diagram of the spectrometer is shown in Fig. 1. As seen in Fig. 1 there will be 8 spectrometers working in parallel. These spectrometers are connected to the outputs of the Converter Racks (CR) A and B of the GBT. The CR's lower and upper cutoff frequencies are 150 MHz and 2 GHz respectively. The analog-to-digital converters (ADCs) in each of the 8 spectrometer will digitize 1.5 GHz bandwidth. A anti-aliasing filter at the output of the CRs restricts the bandwidth to 1.5 GHz. Considering the roll-off of this filter (20 dB in 100 MHz) and the lower cut-off frequency of the CRs, the usable bandwidth per spectrometer is 1250 MHz. Thus the total bandwidth that can be processed with the 8 spectrometers is 10 GHz. We describe below the modifications required in the GBT IF system so that the new spectrometer can process 10 GHz of RF bandwidth.

2 Converter Racks of the GBT

A block diagram of the CR is shown in Fig. 2. There are 4 such blocks in each CR. Thus CRs A and B together will provide the 8 dual polarized outputs for the spectrometer. The band-pass filter in the CR restricts the upper cutoff frequency to 2 GHz. The IF signal from each receiver is fed to the CR through optical fibers (OF). The frequency responses of the IF and OF systems range from 1 to 8 GHz. The local oscillator (LO) in the CR can be tuned anywhere between 1 and 8 GHz with a frequency resolution of 1 KHz. There are 4 such LOs in each CR. Thus a CR can be used to, for example, provide 4 outputs corresponding to the four 1.25 GHz bands for 4 spectrometers. The frequency selection for this case is schematically shown in Fig. 2. Thus the spectrometers connected to CR A can process 5 GHz bandwidth from two polarizations. Similarly, another 5 GHz bandwidth from two polarizations can be processed with the spectrometers connected to CR B.

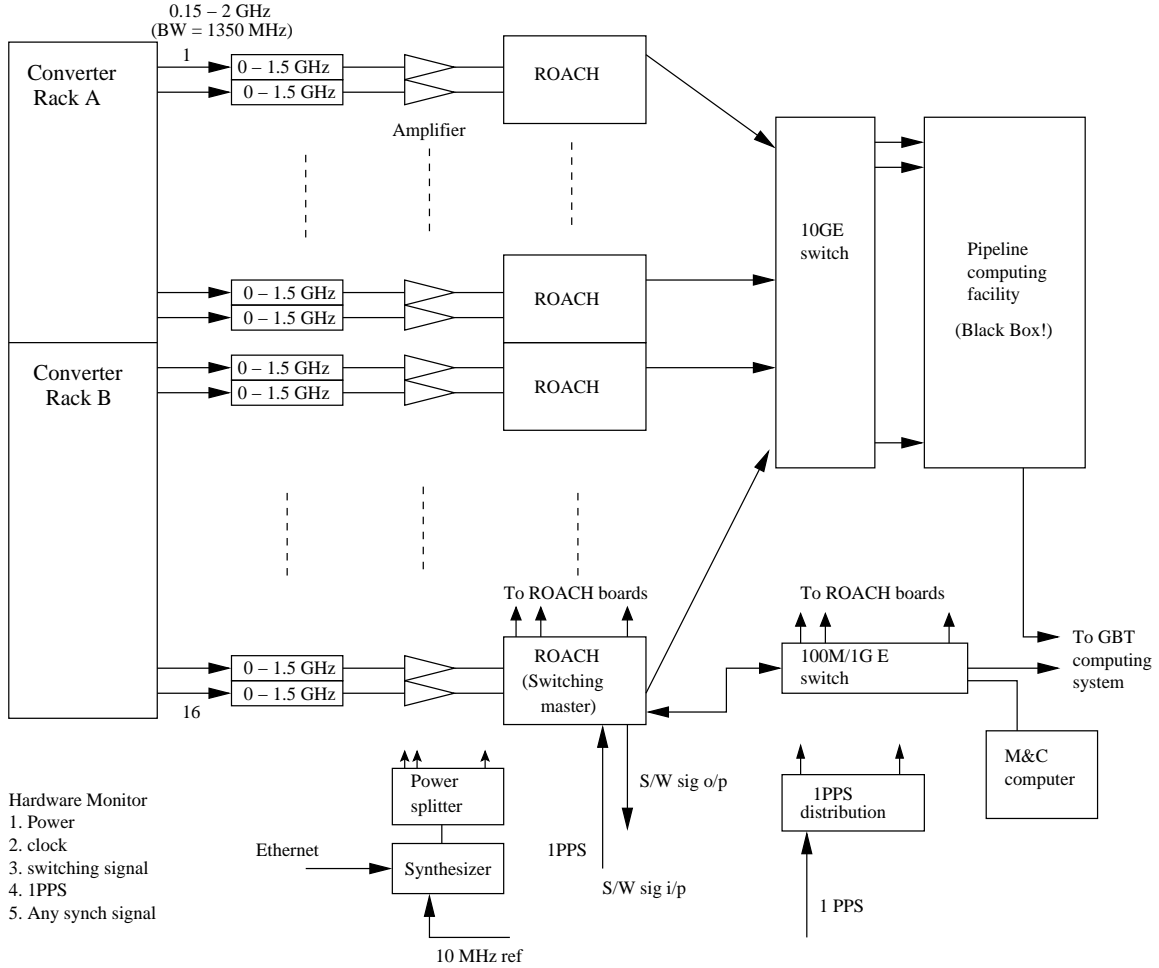
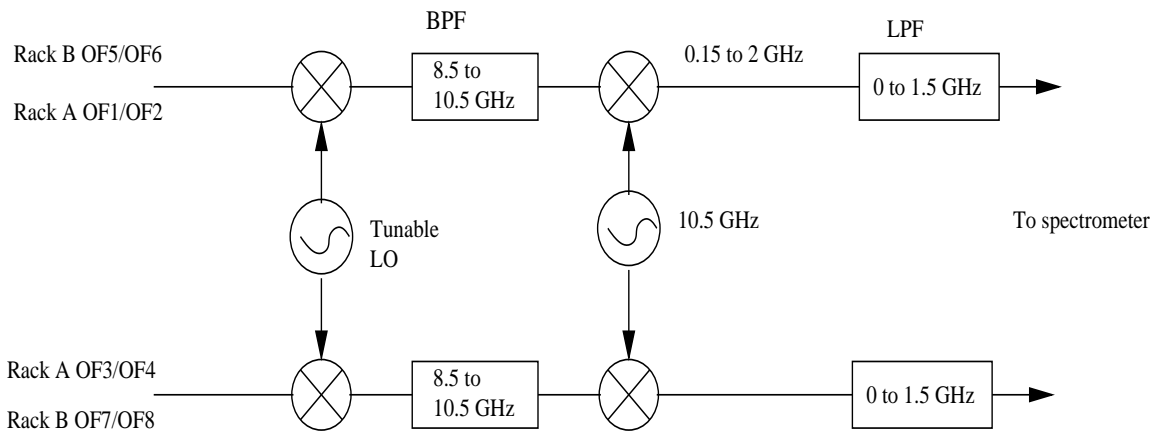
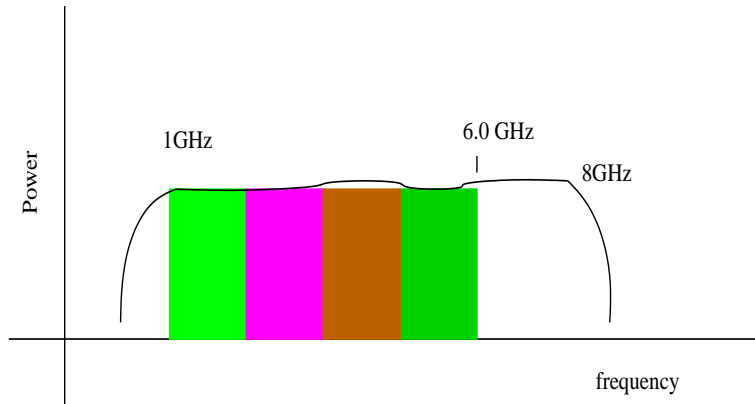

Figure 1: A schematic of the new GBT spectrometer

3 Required Modifications in the GBT IF system

The IF frequency range of most of the receivers above 18 GHz are restricted to 4 GHz or less. Ka-band receiver is an exception, where the full RF bandwidth is available in the intermediate frequency. In the K-band FPA (KFPA) receivers, the bandwidth is restricted to 1.8 GHz in the down-converter module. Similarly in the Q-band receiver the bandwidth is restricted to 4 GHz in the IF system. Modifying the IF system of Q-band is relatively easy compared to modifying the KFPA receiver; the down-converter is an integrated module in the KFPA receiver system.

Here the Ka-band receiver is taken as an example to explain the modifications required to get the 10 GHz IF bandwidth to the spectrometer. A schematic showing the required modifications are shown in Fig. 3. The RF frequency range of Ka-band is 26 to 40 GHz, which is mixed down to 4 to 18 GHz using GBT's LO1-A synthesizer (LO frequency is 44 GHz). This IF will have to be passed through a filter bank as shown in Fig. 3 to get the multiple 8 GHz bandwidth to the CR through different OFs. Such a filter bank is needed for each polarization. LO1-B is available in the GBT system, but LO1-C has to be incorporated into the system.



GBT Converter Rack

Figure 2: A schematic of the GBT Converter Rack (bottom). The selection of 4x1.25 GHz bandwidth using the Converter Rack is shown schematically on the top.

Acknowledgment

We acknowledge the fruitful discussions we had with Roger Norrod regarding the GBT IF system. Roshi, D. A. et al. 2010, GBT memo

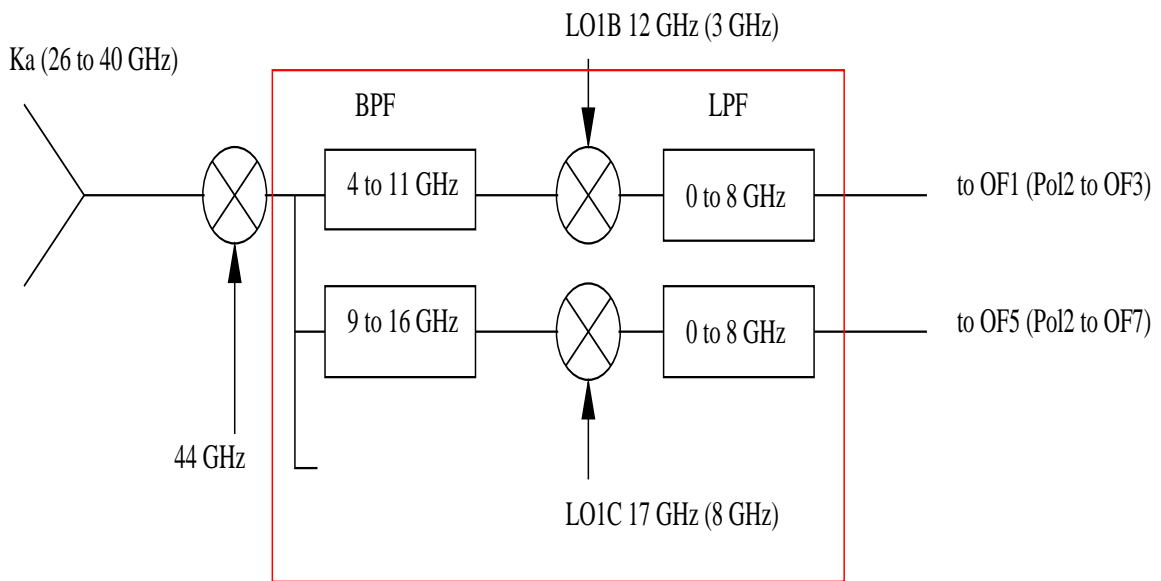

Figure 3: A schematic showing the additional components (shown within the red box) needed in the GBT IF system to operate the spectrometer as a 10 GHz spectrometer.