

**NATIONAL RADIO ASTRONOMY OBSERVATORY  
GREEN BANK, WEST VIRGINIA**

**ELECTRONICS DIVISION TECHNICAL NOTE NO. 183**

Title:           Instruction Manual, NRAO Standard Receiver

Authors:        S. Weinreb and R. Mauzy

Date:            August 1967

DISTRIBUTION:

GB

GB Library  
G. Anderson  
E. Childers  
R. Fisher  
J. Ford  
R. Lacasse  
R. Norrod  
D. Parker  
D. Pedtke  
D. Schiebel  
M. Stennes  
T. Weadon  
S. White

CV

ER Library  
IR Library  
R. Bradley  
C. Burgess  
J. Effland  
R. Escoffier  
N. Horner  
A. R. Kerr  
S.- K. Pan  
G. Petencin  
M. Pospieszalski  
S. Srikanth  
D. Thacker  
A. R. Thompson  
J. Webber

TU

Library-Downtown  
Library-Mountain  
G. Behrens  
M. Brooks  
J. Cheng  
J. Clarke  
J. Cochran  
L. D'Addario  
H. Fagg  
J. Fitzner  
R. Freund  
V. Gasho  
W. Grammar  
J. Kingsley  
J. Lugten  
G. Moorey  
J. Payne  
A. Perfetto  
S. Radford  
G. Reiland  
B. Shillue  
A. Vaccari  
M. Waddel

VLA

AOC Library  
D. Bagri  
L. Beno  
C. Broadwell  
W. Brundage  
J. Campbell  
T. Cotter  
C. Janes  
W. Koski  
R. Latasa  
P. Lilie  
G. Peck  
R. Rhodes  
R. Weimer

INSTRUCTION MANUAL  
NRAO STANDARD RECEIVER

TABLE OF CONTENTS

	<u>Page</u>
I. General Description .....	1
II. Theoretical Description .....	4
III. Detailed Description .....	8
IV. Input-Output Connections and Levels .....	16
V. Schematic Diagrams .....	18
VI. Alignment Procedures	
A. Square Law Detector .....	32
B. Gain Modulator Driver .....	35
C. Synchronous Detector .....	37
D. Synchronous Detector Noise Test .....	39

List of Figures

1) Standard Receiver Block Diagram .....	2
2) Receiver Front Panel Photograph .....	3
3) Model of Switched Radiometer .....	5
4) IF Amplifier Tray .....	9
5) Gain Modulator and Square-Law Detector .....	10
6) Total Power Amplifier .....	12
7) Synchronous Detector Functional Diagram .....	14
8) Square-Law Detector Adjustment Procedure .....	33

INSTRUCTION MANUAL  
NRAO STANDARD RECEIVER

I. General Description

The NRAO Standard Receiver contains the IF, gain modulator, detector, synchronous detector, reference generator, and switch driver portions of a radiometer. It is designed to operate with a wide variety of RF amplifiers and mixers which are mounted at the focal point of the antenna in use.

A block diagram of the receiver is shown in Figure 1 and a photograph is shown in Figure 2. The receiver can accept input signals of 3 types:

- 1) A detected signal of 1 volt DC level. This type of input comes from tunnel-diode TRF receivers which have detectors in the front-end box.
- 2) A low-level IF signal which arises when an RF amplifier and a mixer are in the front-end box. The IF signal must have a frequency spectrum between 1 Mc/s and 300 Mc/s and must be at a level  $>-70$  dBm at the input of the receiver.
- 3) A high-level IF signal which arises when an RF amplifier, mixer, and IF amplifier are in the front-end box. The signal level must be between  $-25$  and  $-35$  dBm and the signal spectrum must also be within the 1 Mc/s to 300 Mc/s range.

A brief description of the components of the standard receiver is as follows:

IF Amplifier — The IF amplifier is made up of 2 wideband amplifier modules, an input step attenuator, and various filters. These components are contained in a slide-out drawer and are patched together to make up the desired gain and frequency response.

IF Gain Modulator — This unit multiplies the receiver gain by a factor,  $\alpha$ , when the front-end switch is in the reference position; the gain is unaffected when the front-end switch is in the antenna position. The gain modulation factor,  $\alpha$ , can be varied from .107 to 2.34 with high precision through the operation of a switched, coarse (1 dB steps) attenuator and a continuously variable, fine ( $\pm .7$  dB) attenuator. Gain modulation is used to balance the radiometer and make its output independent of gain fluctuations; this is discussed in the next section. The gain modulator, square-law detector, and total power amplifier are all housed in one chassis. This unit also contains attenuators for adjusting the IF gain.

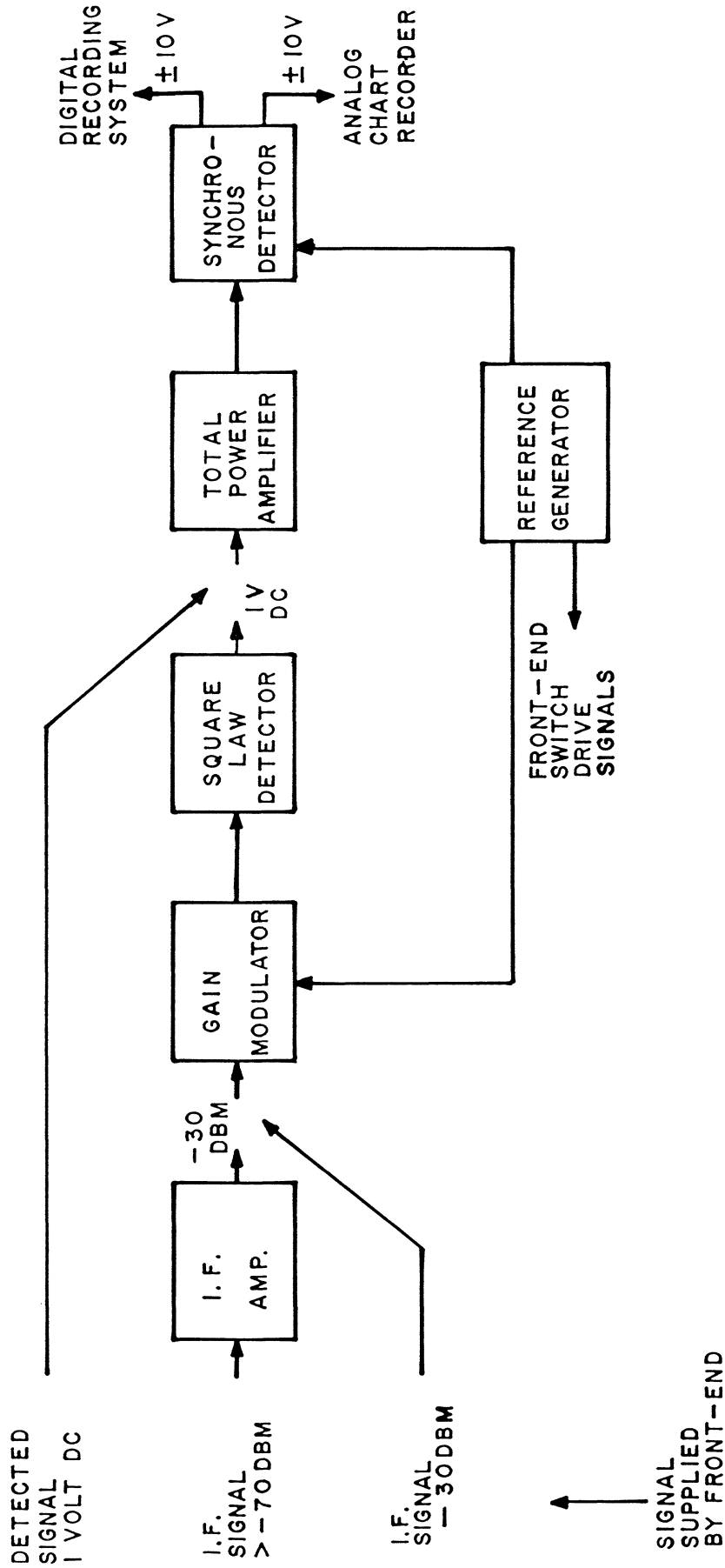

Figure 1 — Standard Receiver Block Diagram

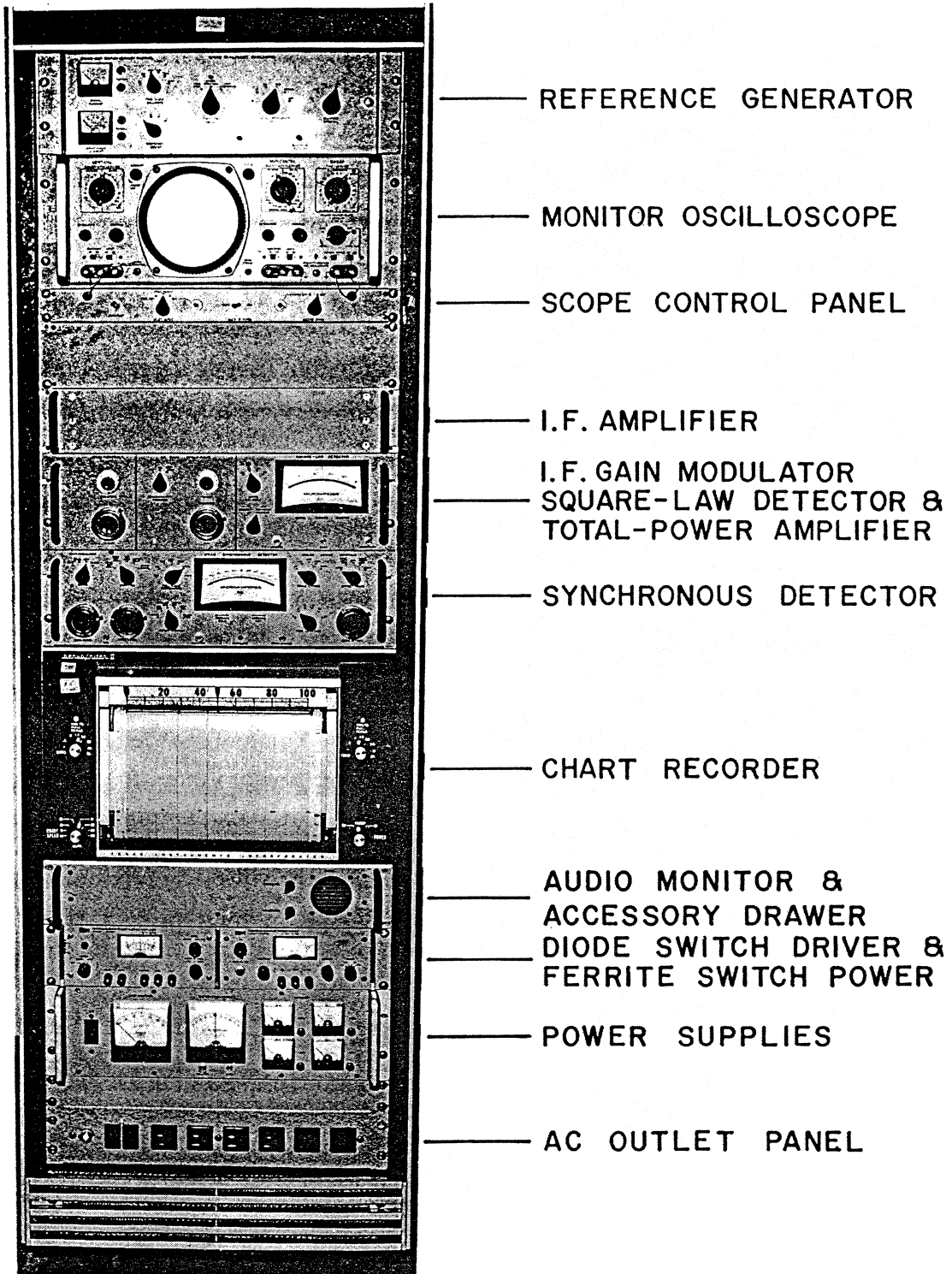

Figure 2 — NRAO Standard Receiver

Square-Law Detector — A detector which is carefully adjusted for square-law operation is incorporated in the receiver. The detector output will normally be within 2 percent of square-law for total power outputs between 0.3 volts and 3 volts (nominal total power output is +1 volt). A detector-law calibration curve is normally supplied with each radiometer.

Total Power Amplifier — This unit contains an optional 60 $\sim$  rejection filter and optional blanking circuits to remove the effects of front-end switch and gain-modulator transients. A meter which indicates the total power output is provided. The center scale of this meter can be expanded by x 10 to show small variations in the receiver total power.

Synchronous Detector — The synchronous detector extracts the switched component (antenna minus reference) of the total power output and provides the normal radiometer output. This unit contains a post-detection gain modulator that is used with TRF front-ends (which have no IF and therefore cannot use the IF gain modulator). The synchronous detector contains various gain, offset, and time constant controls. It provides outputs for a digital recording system and for an analog chart recorder.

Reference Generator — The reference generator provides square wave signals at frequencies of 1, 10, 50 and 400 cycles per sidereal second. These signals drive the synchronous detector, the IF gain modulators, and switch drivers for front-end switches. Two types of switch drivers are included. One provides a  $\pm 20$  volt, 0.5 amp maximum square-wave for driving diode switches; the second provides up to 90 volts at .75 amps for driving ferrite switches. The reference generator also provides blanking signals for use in the total power amplifier and synchronous detector.

## II. Theoretical Description

The NRAO Standard Receiver, when connected to a suitable front-end, forms a switched (Dicke) radiometer. The receiver is somewhat unconventional in that gain modulation and square-wave synchronous detection are utilized. These two aspects will be emphasized in this section.

The radiometer can be analyzed with reference to the block diagram shown in Figure 3. All of the switches in the figure are switched synchronously at a 1, 10, 50, or 400 cps rate. When all the switches are in the upper (antenna) position, the average total-power output signal is,

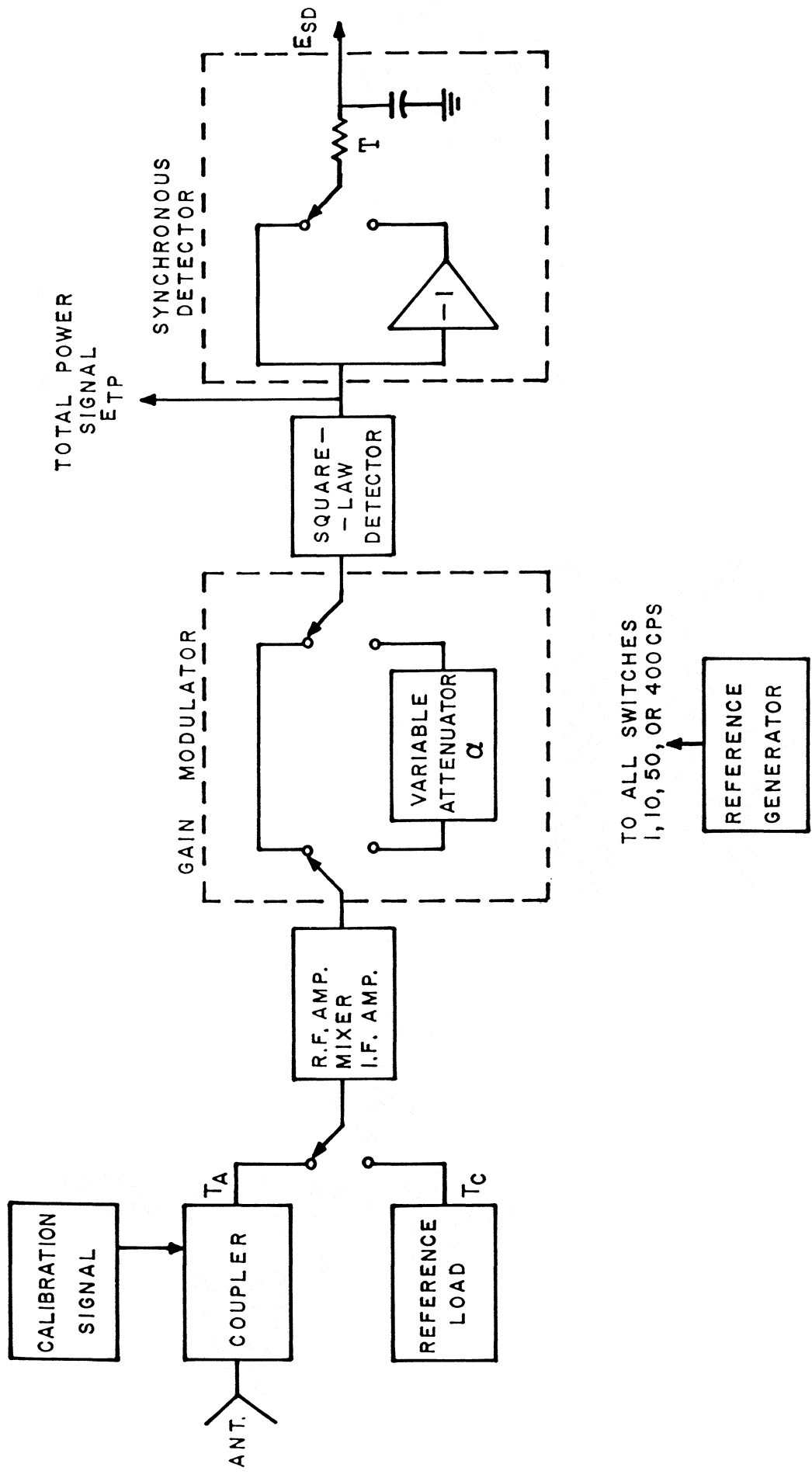

TO ALL SWITCHES  
1, 10, 50, OR 400 CPS

REFERENCE  
GENERATOR

Figure 3 — Simple Model of Switched Radiometer with Gain Modulation

$$\overline{E_{TP}} = G(T_A + T_R)$$

where  $G$  is the receiver gain,  $T_A$  is the antenna temperature, and  $T_R$  is the receiver noise temperature.

When the switches are in the lower (reference) position the output is,

$$\overline{E'_{TP}} = \alpha G(T_C + T_R)$$

where  $\alpha$  is the gain modulation ratio and  $T_C$  is the reference load temperature.

The synchronous detector extracts the average value of the difference of  $E_{TP}$  and  $E'_{TP}$ ; thus its output is

$$E_{SD} = G[T_A - \alpha T_C - (1 - \alpha)T_R]$$

The purpose of the switching system is to allow  $T_A$  to be measured independent of small drifts in  $G$  and  $T_R$ . This performance is illustrated by examining the incremental change in  $E_{SD}$  caused by incremental changes in  $T_A$ ,  $G$ , and  $T_R$ . The resultant  $\Delta E_{SD}$  is divided by  $G$  to put it in units of temperature; this quantity is designated as  $(\Delta T_A)_{meas}$  and is given by

$$(\Delta T_A)_{meas} = \Delta T_A + \frac{\Delta G}{G} T_u - (1 - \alpha)\Delta T_R$$

where  $T_u = T_A - \alpha T_C - (1 - \alpha)T_R$ .

The gain modulation factor,  $\alpha$ , can always be adjusted to make the unbalance temperature,  $T_u$ , equal to zero. This makes the measured antenna temperature independent of the receiver gain. (Note that it does not matter if the gain change occurs before or after the gain modulator.) However, unless  $T_A = T_C$  and  $\alpha = 1$ , the measured antenna temperature will be dependent on the receiver noise temperature. The ideal condition is, of course,  $T_A = T_C$  and  $\alpha = 1$ ; however, this often cannot be achieved because of the difficulty of obtaining a stable, adjustable, cold reference temperature,  $T_C$ .



The receiver noise temperature is usually quite stable and often  $T_C$  is close to  $T_A$  so that  $\alpha$  is nearly 1. Under these conditions, gain modulation is quite useful.

In most Dicke radiometers a narrow-band audio amplifier tuned to the switch frequency is used between the square-law detector and the synchronous detector. In the past this was necessary because synchronous detectors could not be built with sufficient dynamic range to tolerate the wideband noise signal coming out of the detector. This is no longer true and the following five advantages result if the narrow-band amplifier is omitted:

1) The receiver sensitivity is increased by  $\pi/2\sqrt{2} = 1.11$  because higher harmonics of the switch frequency are kept.

2) A post-detection gain modulator can be used. This type of gain modulator is useful in TRF receivers which cannot use an IF gain modulator. The post-detection gain modulator will not remove the effects of all gain changes if the detector is not perfectly square-law. The NRAO standard receiver has both types of gain modulators.

3) Switching transients can be "blanked" out after detection. The blanking operation can be performed by keeping the synchronous detector switch in a middle or "dead band" position for a short instant of time after each square-wave transition. The capacitor (in Figure 1) holds the previous voltage value and no "hole" is put in the output signal during the blanking interval.

4) The switch frequency can be changed without making any other changes in the receiver. The switch frequency is usually chosen as high as the front-end switch will allow. This varies with the type of front-end switch — diode, ferrite, or mechanical.

5) The output of the square-wave synchronous detector is a smooth DC signal even if the time constant is shorter than a switch period. This is useful in some applications which require very low switch frequencies or very short time constants.

A disadvantage of omitting the narrow-band amplifier is an increased sensitivity to spurious 60 cps modulation. At a 50 cps reference frequency a 10 cps beat note can appear in the synchronous detector output. This signal is attenuated by the output time constant but it can still be a source of difficulty. For this reason, the receiver has an optional 60 cps rejection filter. The filter is optional because it distorts the square-wave modulation waveform; this may be harmful in some cases.

The theoretical RMS fluctuation of the NRAO standard receiver is given by,

$$\Delta T = \frac{\sqrt{2} (T_R + T_A)}{\sqrt{B\tau}}$$

when B is the IF or RF noise bandwidth and  $\tau$  is the RC time constant. If an ideal integration over a time period,  $\tau$ , is used, then the RMS fluctuation is  $\sqrt{2}$  times larger.

### III. Detailed Description

#### A. IF Amplifier

A block diagram of the components in the IF amplifier tray is shown in Figure 4. These components can be patched together in various combinations. Coaxial pads are sometimes required to isolate the amplifiers and filters.

The input attenuator in the IF amplifier tray is set to a nominally correct value when the receiver front-end is installed. The GAIN CONTROLS, located on the gain modulator chassis, are then used to make up small variations. The 1 DB STEPS control gives a  $\pm 6$  dB variation in IF attenuation proceeding the gain modulator. A 0-3 dB 5-turn control is used to give a fine variation in the gain after detection. The GAIN CONTROLS should be adjusted to give a 1 volt reading on the total power output meter. This output is not critical and outputs between 0.5 volt and 2 volts will cause no harm.

#### B. Gain Modulator

A block diagram of the gain modulator and square-law detector is shown in Figure 5. The gain modulation is accomplished by switching with diode switches between a fixed attenuator (in the circuit when the front-end switch is in the antenna position) and a variable attenuator. The variable attenuator is the COARSE GAIN RATIO control on the front panel. This control varies the gain modulation factor,  $\alpha$  (defined in Section I), from -9 dB (.126) to +3 dB (2.0) in 1 dB steps.

The FINE GAIN RATIO control is a 10-turn potentiometer which gives a  $\pm 0.7$  dB variation in the gain modulation factor; the resolution of this control is approximately  $\pm .001$  dB. The variation of attenuation is produced by adjusting the current through variable-resistance PIN diodes in gain modulator switches.

AVAILABLE FILTERS	
$f_0$	BW
30	1 MC
30	3
30	10
150	3
150	8
150	20
150	50

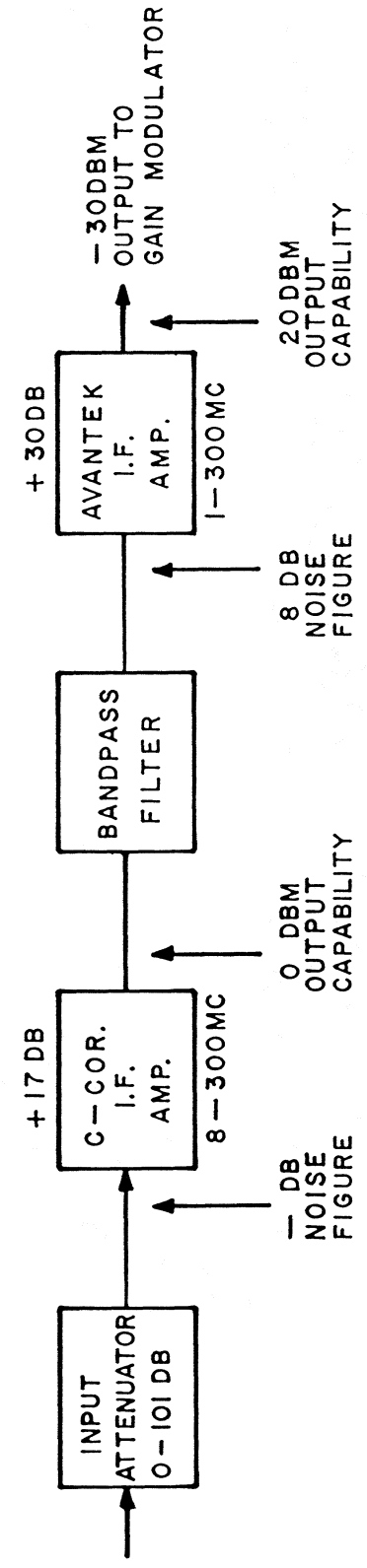

Figure 4 - IF Amplifier Tray

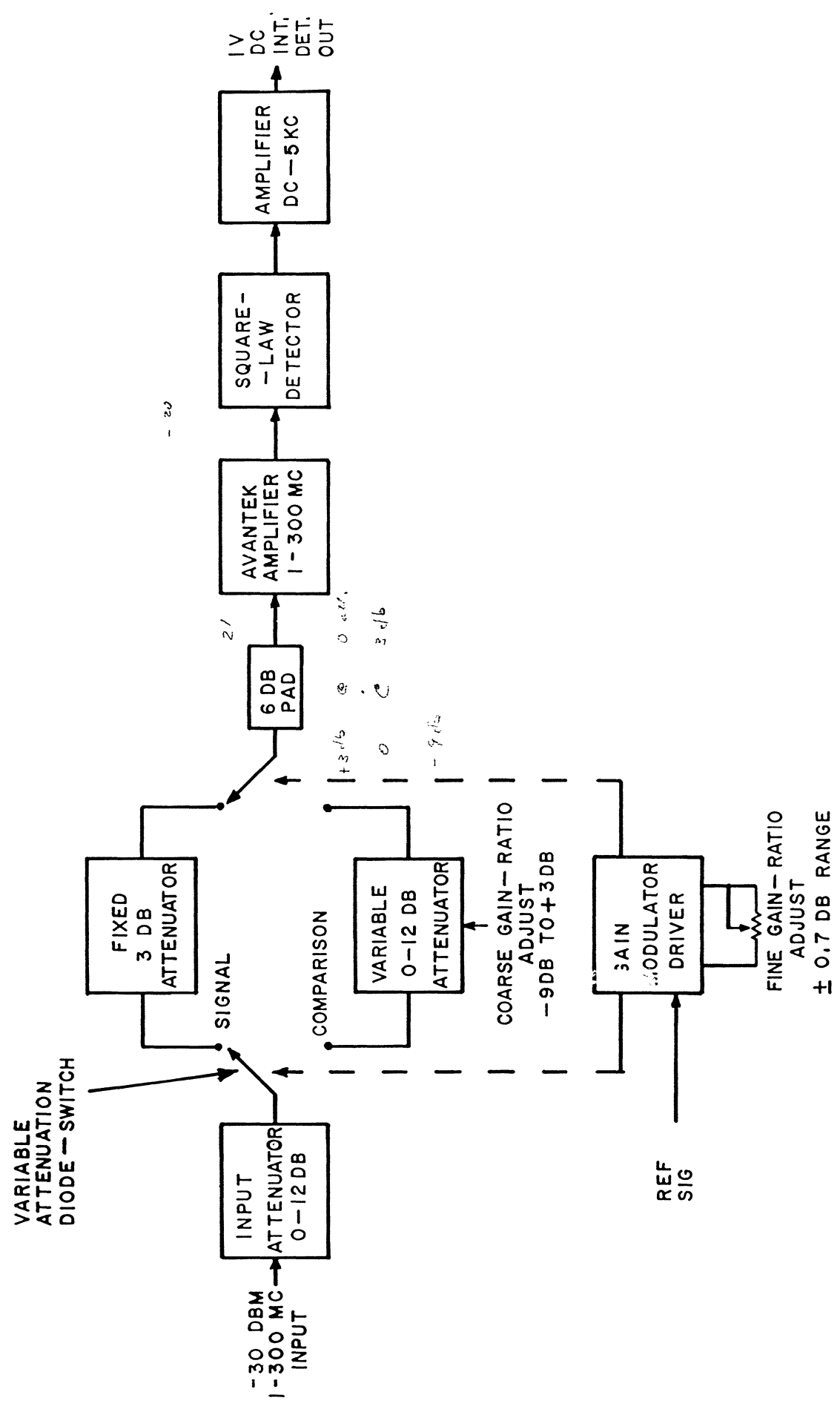

Figure 5 -- Gain Modulator and Square-Law Detector

B. (continued):

The GAIN MODULATOR OPERATION switch allows the gain modulator to be turned OFF (locked in a fixed attenuation position), ON (modulated), or LOCK COMP (locked in the variable attenuator position).

C. Total Power Amplifier

The total power amplifier supplies a differential input, a 60 cps rejection filter, a blanking circuit, and metering circuits for the total power signal. The amplifier has unity gain and normally operates with 1 volt DC input and output. The input may arise from the internal square-law detector or from an external detector; this choice is made at the receiver top panel. A block diagram of the unit is shown in Figure 6.

The 60 CPS FILTER switch on the front-panel allows the 60 cps filter to be inserted (IN) or removed (OUT). The filter should only be used if there is a 60 cps spurious signal evident on an oscilloscope presentation of the total power signal. This 60 cps signal will cause a 10 cps beat note to occur on the synchronous detector output if a 50 cps reference frequency is used. A 60 cps spurious signal will have less effect at the other switch frequencies. The rejection filter will reduce the 60 cps signal by at least a factor of 10 but causes some distortion of the switched signal waveform; this distortion may increase the RMS fluctuation slightly.

The blanking circuit is to eliminate switch transients before they can overload further circuitry. The BLANKING INTERVAL switch on the reference generator adjusts the fraction of the switch cycle which is blanked. This fraction reduces the effective integration time and should be kept as small as possible. The BLANKING INTERVAL should be adjusted by observing the switch transients on the total power signal.

A 0-3 DB GAIN CONTROL allows a fine adjustment of gain. The helipot dial setting (500 to 1000) can be interpreted directly as a .500 to 1.000 gain multiplier.

The METER MID-SCALE switch allows the meter range to be changed. The usual setting is IV; the gain controls should then be adjusted so that the meter reads mid-scale. The NORMAL - X 10 SCALE EXPAND allows the middle 10 percent of the meter scale to be expanded by a factor of 10 to measure small changes in total power. A X10 scale expand output with a 1 second time constant is also provided to drive a chart recorder. This output is independent of the NORMAL - X 10 SCALE EXPAND switch setting but is dependent upon the METER MID-SCALE switch setting. The synchronous detector output is independent of both switch settings.

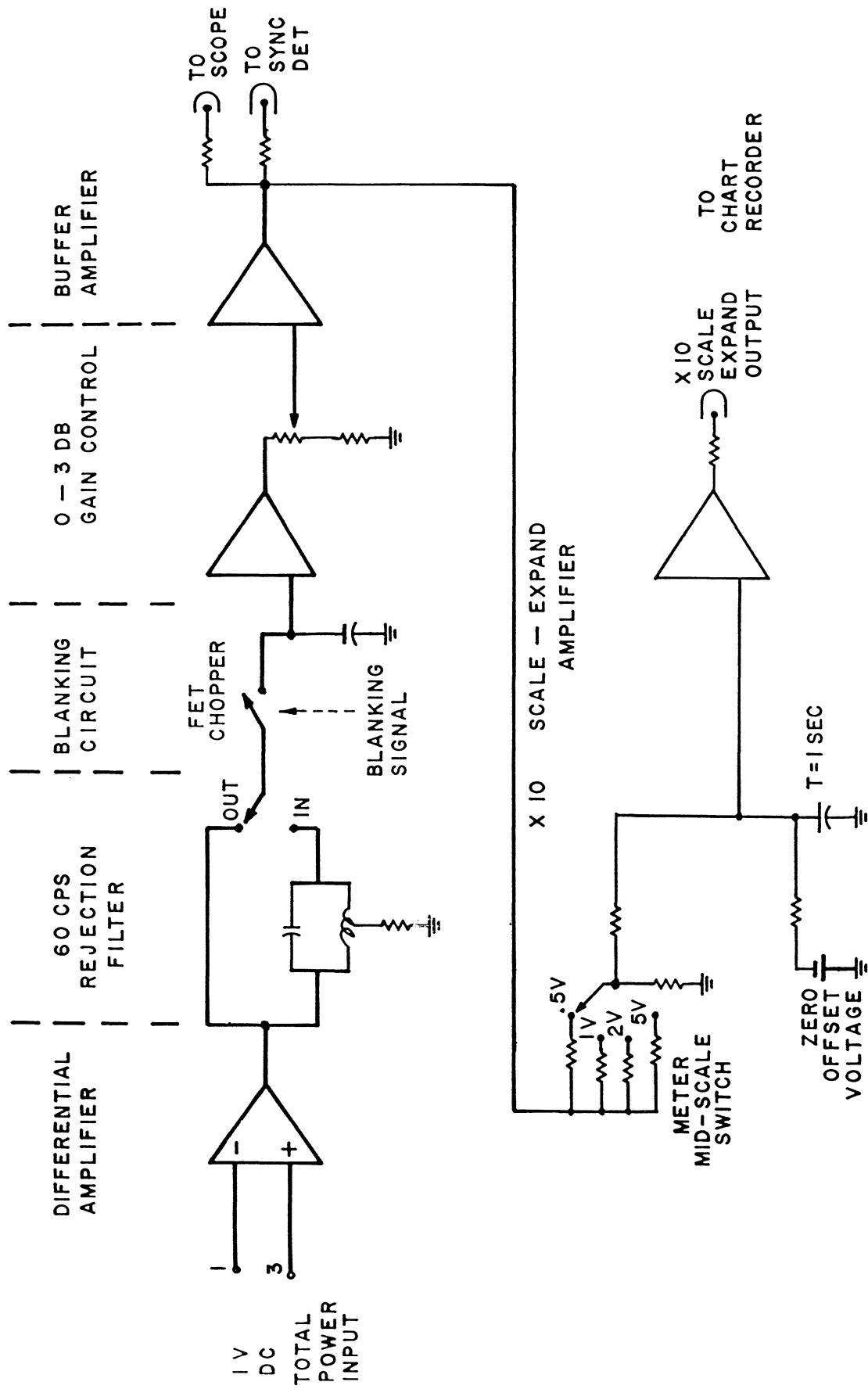

Figure 6 — Total Power Amplifier Block Diagram

C. (continued):

The ZERO TEST push button removes the RF signal from the detector and is useful for zero setting the total power output. This zero setting is important only for linearity measurements and for receiver noise temperature measurements.

D. Synchronous Detector

A block diagram of the synchronous detector is shown in Figure 7. The unit is quite complex because in addition to a basic synchronous detector it has a differential input (to eliminate ground problems), a post-detection gain modulator, scale controls, a variety of time constants, a high resolution zero offset, blanking circuits, and overload detection circuits.

The FUNCTION switch selects the mode of operation. In most cases this is the SYNC DET > 10 CPS position. If the reference frequency is < 10 cps, the SYNC DET < 10 CPS position should be used; the unit then operates correctly for reference frequencies down to 1 cps but has a long overload recovery time. In the other positions of the FUNCTION switch the unit does not function as a synchronous detector. In the TOT PWR position the receiver total power is measured. In the GATED SIG and GATED COMP positions the total power during antenna and comparison switch cycles is measured. The following table may be useful:

FUNCTION SWITCH SETTING	OUTPUT PROPORTIONAL TO
SYNC DET $\begin{matrix} > \\ < \end{matrix}$ 10	$T_A - T_C$
TOT PWR	$T_R + 1/2 T_A + 1/2 T_C$
GATED SIG	$T_R + T_A$
GATED COMP	$T_R + T_C$

where  $T_R$  is the receiver noise temperature,  $T_A$  is the antenna temperature, and  $T_C$  is the reference load temperature.

The GAIN MODULATOR RANGE switch allows the post-detection gain modulator to be turned OFF or allows selection of various ranges for the gain modulation ratio,  $\alpha$ . The GAIN RATIO control then gives a linear ( $\pm 0.25$  percent) variation in the selected range.

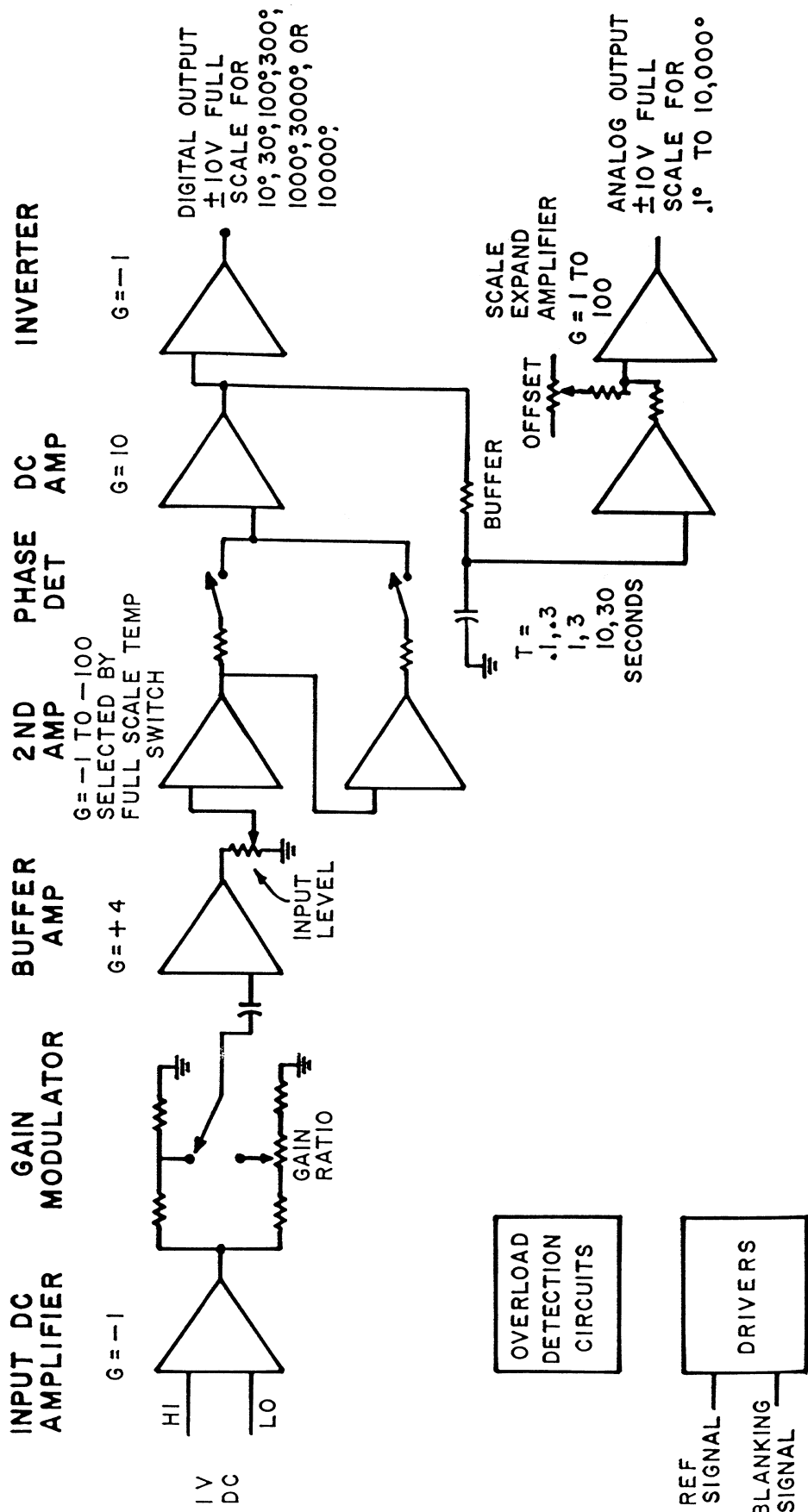

Figure 7 -- Synchronous Detector Functional Diagram



The INPUT LEVEL control is simply a gain control; it should be adjusted so that the FULL SCALE TEMPERATURE ranges are correct as tested with a calibration signal. This will occur when the INPUT LEVEL helipot dial setting (0 to 1000) is set equal to the system noise temperature and the total power output voltage is 1 volt. If the system noise temperature is  $> 1000^\circ$ , then the total power output should be increased to K volts and the INPUT LEVEL control will have a range of 0 to  $K \times 1000$  degrees.

The FULL SCALE TEMPERATURE range switch refers to the maximum temperature (before overload) which can be tolerated on the digital output or on the analog output with SCALE EXPAND at X1. This full scale temperature gives 10 volts output and will drive the meter to full scale.

The METER-MONITOR switch selects the variable displayed on the meter and presented on the front-panel and rear-panel monitor jacks. In the INPUT position, the total power voltage is monitored (the meter must read left of center). The most often used positions are ANALOG OUT and DIGITAL OUT which allow monitoring of the two synchronous detector outputs. The meter scale is always  $\pm 10$  volts full scale.

All of the controls to the right of the meter affect only the analog output signal. The SCALE EXPAND switch allows the full scale temperature ( $\pm 10$  volts output) to be reduced by up to  $\times 100$  with an accuracy of  $\pm 2\%$ . The OFFSET RANGE switch and ZERO OFFSET controls allow the analog output zero to be shifted up to the full scale temperature (before expansion) value. The TIME CONSTANT switch allows selection of time constants between 0.1 second and 30 seconds of the analog output. (The digital output time constant is 20 ms.)

IV. Input-Output Connections and Levels

Power 120 V, 60 Hz power is supplied to the rack through a 3-prong twist-lock connector located in the lower left corner of the back of the rack.

Power is available in the rack on two fused terminal strips, one of which is available from the front of the receiver.

Top Panel All necessary connections to the standard receiver can be made on the top panel. Please note which connections should be jumpered together for normal operation.

Name	Level In or Out	Type of Connector	Drawing S 2.462-	Function
Ref x 128 Out	0 to -6 V	BNC	1	To slave another reference generator jumper to Ext Ref In and set frequency selector switch to Ext/128.
Ref Out	0 to -6 V	BNC	1	Additional reference output.
Sampling Sync	0 to -6 V	BNC	1	Output for synchronizing a digital output system to reference frequency. (There is no connection to this jack on most receivers.)
Spare	---	BNC feed through		
Spare	---	BNC feed through		
Ref Sync Input	0 to -6 V	BNC	1	Used to Sync Ref generator to a timing signal. A positive going pulse will reset all Ref Gen counters to a logical "0".
Spare	---	BNC		
Ext Ref In	0 to -6 V	BNC	1	Input used to slave Ref Generators. (See Ref x 128 Out.) Note — When frequency selector switch is set to external, a 0 volt signal on the Ext Ref In produces a -6 V at the Ref Out.
Scope In-Out	---	Floating BNC feed through	11	This is connected directly across the vertical input of the oscilloscope.
IF Out	-30 dBm nominal	BNC feed through	4	Output of IF amplifier tray.
Int Det Out	+1 V DC	BNC feed through	8	Output of HP 423A detector.
TP x 10 Out	1 V/10% gain change	BNC feed through	8	Total power output for chart recorder. One volt represents 10% gain change
Sync Det Analog Out	0 to ± 10 V	BNC feed through	13	Output for chart recorder

VI. (continued):

Name	Level In or Out	Type of Connector	Drawing S2.462-	Function
Spare	---	BNC feed through		
Ferrite Switch	0 to $\pm 100$ V	4 Pin MS/AN	2	Drive for ferrite switch 100 V, 0.9 amp maximum.
Marker Input	Depends on type of Chart Recorder	4 Pin MS/AN		Connects to marker pens on edges of chart recorder.
Input	-70 dBm 2-300 MHz	Type N	4	IF input to receiver.
G.M. In	-30 dBm nominal	BNC feed through	5	Gain modulator input.
Det Signal In	+1 V DC	3 Pin Audio	8	Input for detected signal.
Chart Recorder A	0 to $\pm 10$ V	3 Pin Audio		Chart recorder inputs Pin No. 1 positive Pin No. 2 negative Pin No. 3 ground
Chart Recorder B	0 to $\pm 1$ V	3 Pin Audio		
Spare	----	4 Pin MS/AN		
Diode Switch	0 to $\pm 20$ V	4 Pin MS/AN	2	Drive for diode switch $\pm 20$ V, 0.5 amp.
Sync Det Dig Out	0 $\neq$ 10 V	BNC feed through	13	A 0 to $\pm 10$ V DC output from the synchronous detector for use by the digital recording system.

In Normal Operation, these will be jumpered on the top panel:

IF OUT	to	G. M. IN
INT DET OUT	to	DET SIG IN
T. P. X 10 OUT	to	CHART RECORDER A
SYNC DET ANALOG OUT	to	CHART RECORDER B

Switch Drive Connections

Improper switch connections can damage the switch.

Diode Switches

There is no current limiting built into the standard receiver. Level and zero controls are on the Harrison 6823A power amplifier. See Standard Receiver Switch Driver Wiring - Dwg. No. S2.462-2.

Ferrite Switches

See: Standard Receiver Ferrite Switch Load Resistor Plate - Dwg. No. S2.462-6, and Standard Receiver Switch Driver Wiring - Dwg. No. S2.462-2.

For single tap coil current flows from A to B during signal. For center tap, current flows out B during signal.

Switch connections should always be checked with dummy loads before connecting switch.

## V. Schematic Diagrams

<u>Title</u>	<u>Drawing Number</u>	<u>Page Number</u>
Reference Generator .....	S2.462-1	19
Switch Driver Wiring .....	S2.462-2	20
Switch Driver Current Monitor .....	S2.462-3	21
Power Supply Module .....	S2.462-4	22
Power Amplifier Driver .....	S2.462-5	23
Ferrite Switch Load Resistor Plate .....	S2.462-6	24
Switch Driver Module (Ferrite) .....	S2.462-7	25
Square Law Detector, Blanking and 60 Hz Rejection Filter, X10 Total Power Amplifier .....	S2.462-8	26
Gain Modulator Driver .....	S2.462-9	27
Audio Monitor Schematic .....	S2.462-10	28
Scope Control Panel Wiring .....	S2.462-11	29
Power Supply Wiring .....	S2.462-12	30
Synchronous Detector .....	S2.462-13	31

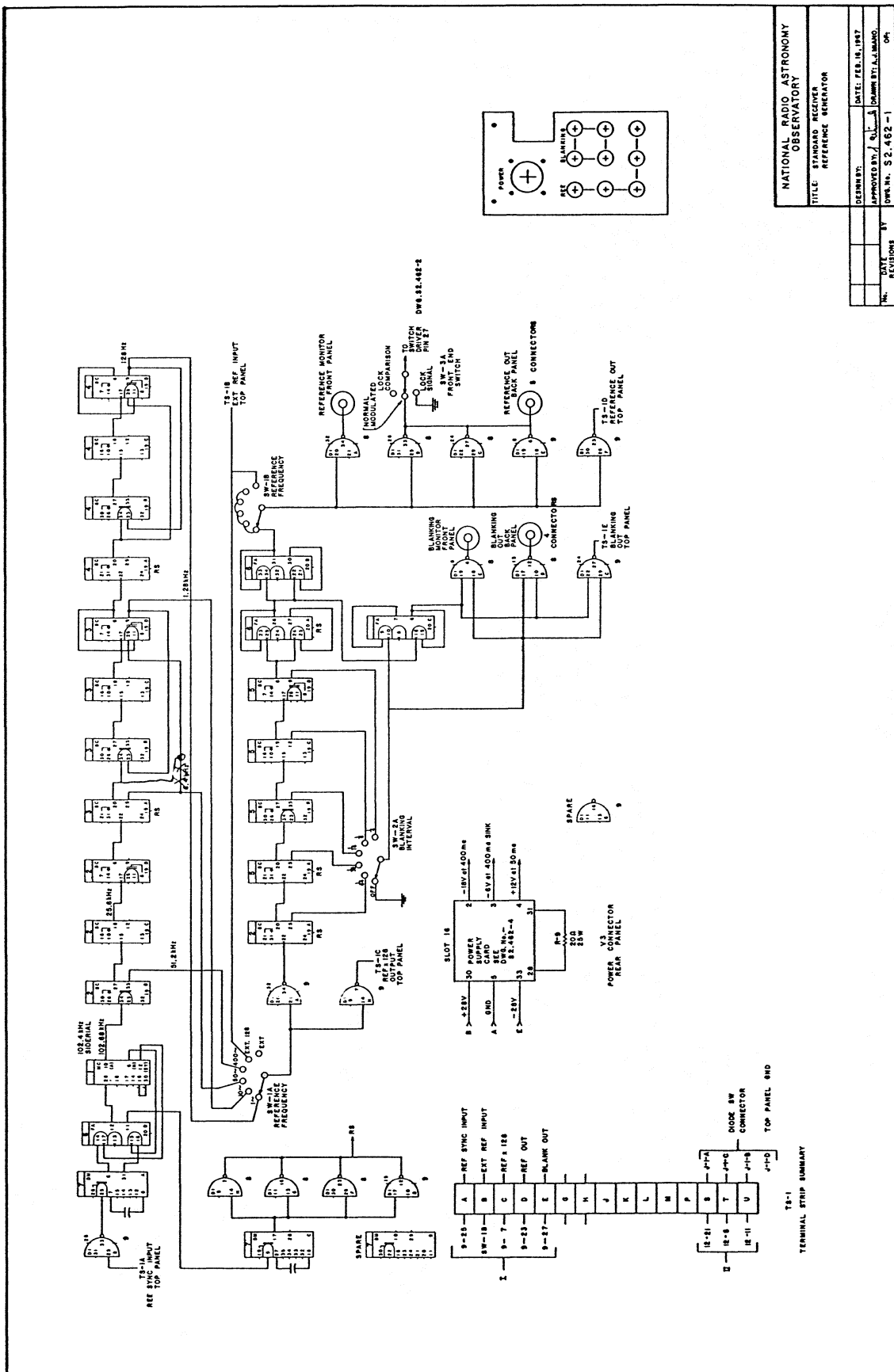

NATIONAL RADIO ASTRONOMY  
OBSERVATORY

TITLE: STANDARD RECEIVER  
REFERENCE GENERATOR

DESIGNED BY: [ ] DATE: FEB. 16, 1957

APPROVED BY: [ ] DRAWN BY: J. J. MANGO

No. [ ] DATE [ ]

Revisions: [ ]

DWG. No. S2.462-1

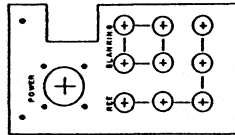

▽ = SEE DWG. NO. S 2.462-5  
 ▽ = SEE DWG. NO. S 2.462-7  
 ▽ = SEE DWG. NO. S 2.462-5  
 ▽ = SEE DWG. NO. S 2.462-6

CURRENT METER WIRING ON DWG. NO. S 2.462-3

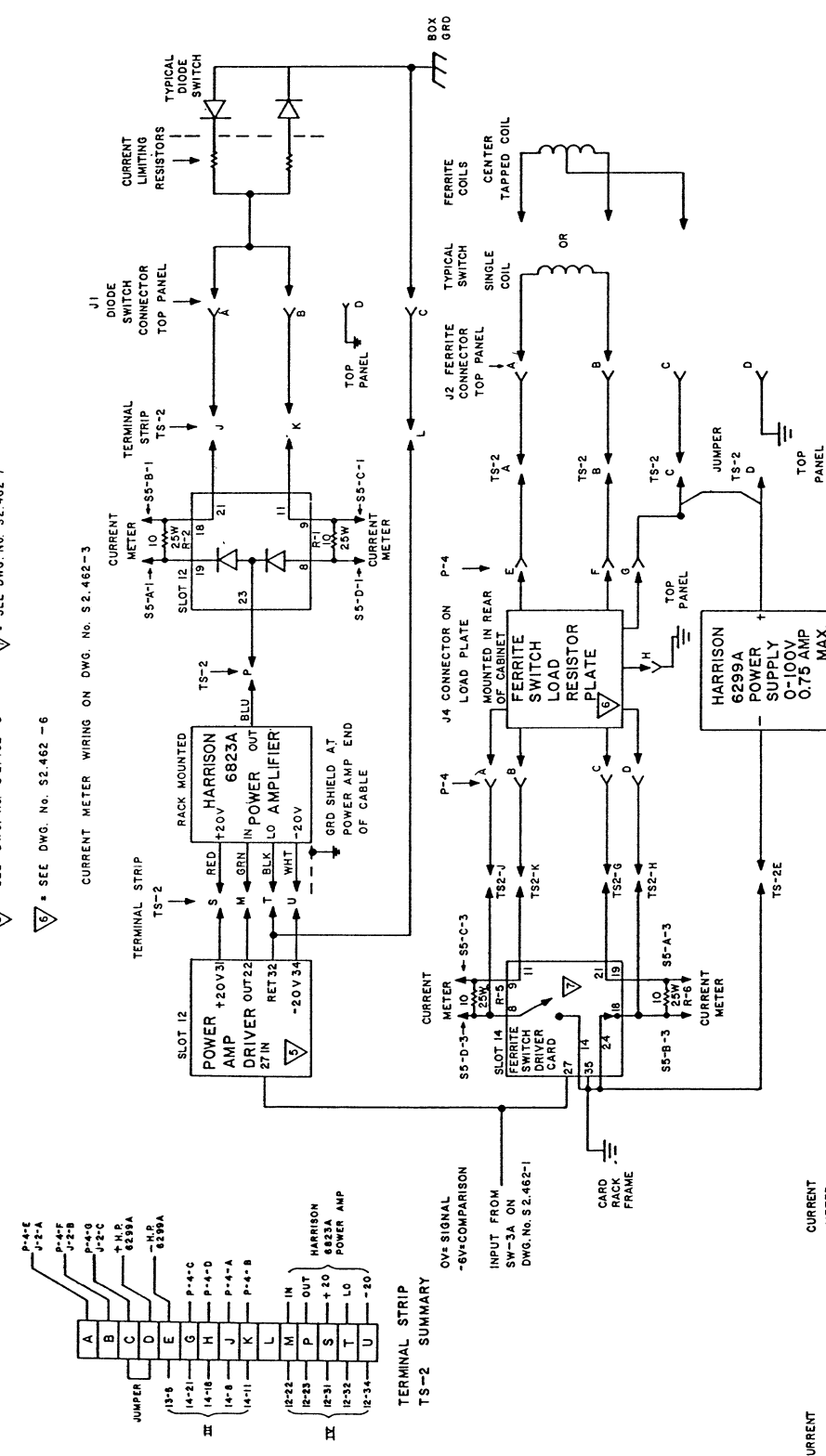

TERMINAL STRIP SUMMARY  
 TS-2

A	P-4-C	OV= SIGNAL
B	J-2-A	-6V=COMPARISON
C	P-4-F	INPUT FROM SW-3A ON DWG. NO. S 2.462-1
D	P-4-E	
E	P-4-D	
F	P-4-C	
G	P-4-B	
H	P-4-A	
I	P-4-A	
J	P-4-B	
K	P-4-C	
L	P-4-D	
M	P-4-E	
N	P-4-F	
O	P-4-G	
P	P-4-H	
Q	P-4-I	
R	P-4-J	
S	P-4-K	
T	P-4-L	
U	P-4-M	
V	P-4-N	
W	P-4-O	
X	P-4-P	
Y	P-4-Q	
Z	P-4-R	

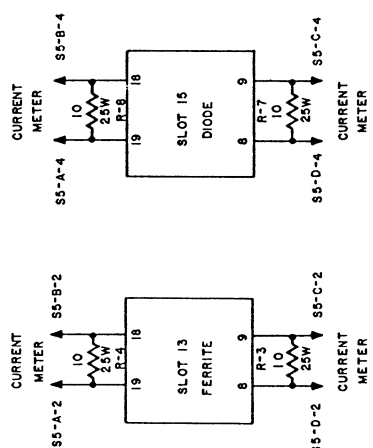

NATIONAL RADIO ASTRONOMY  
 OBSERVATORY

TITLE: STANDARD RECEIVER  
 SWITCH DRIVER WIRING

DESIGN BY: S. WEINREB  
 DATE: 3/2/67

APPROVED BY:  
 DRAWN BY: D. M. HAMED

No. DATE REVISIONS BY

1 6/23/67 D.M.H. J.C.W.

DWG. No.: S 2.462-2

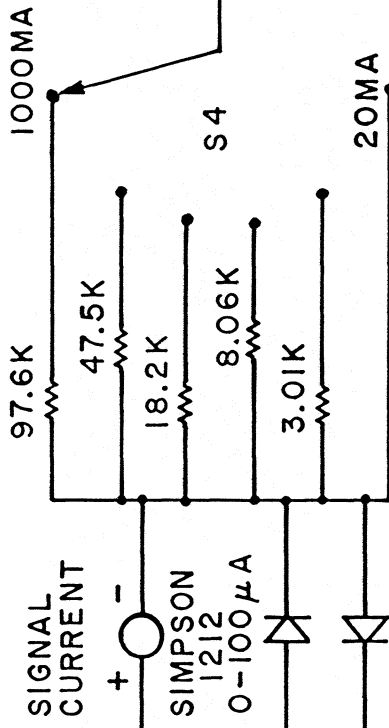
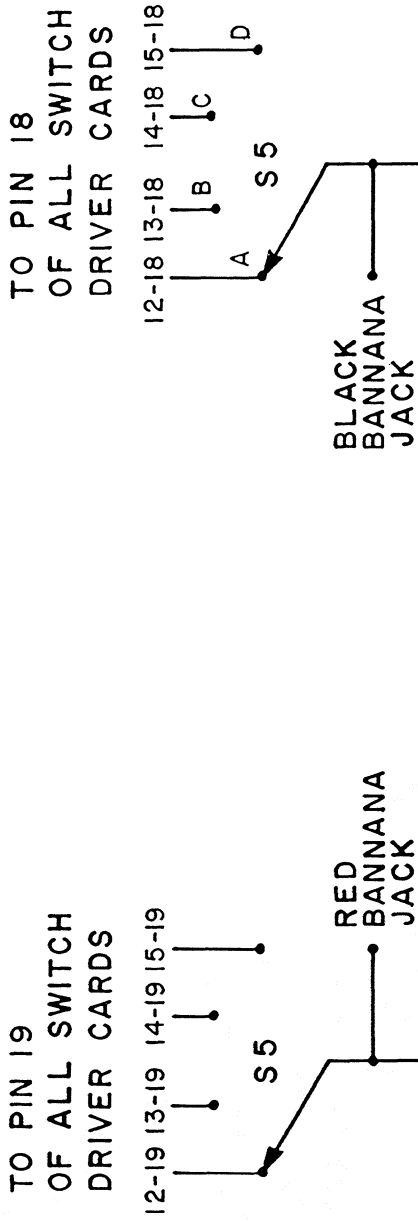

WIRING OF COMPARISON CURRENT  
METER IS IDENTICAL EXCEPT  
PINS 9 & 8 ARE USED.

NATIONAL RADIO ASTRONOMY OBSERVATORY	
TITLE: STANDARD RECEIVER SWITCH DRIVER CURRENT MONITOR	
DSGN.BY: S.WEINREB	DATE: 2-12-66
APPD.BY:	DR.BY: A.J.MIANO
DWG.NO. S2-462-3	

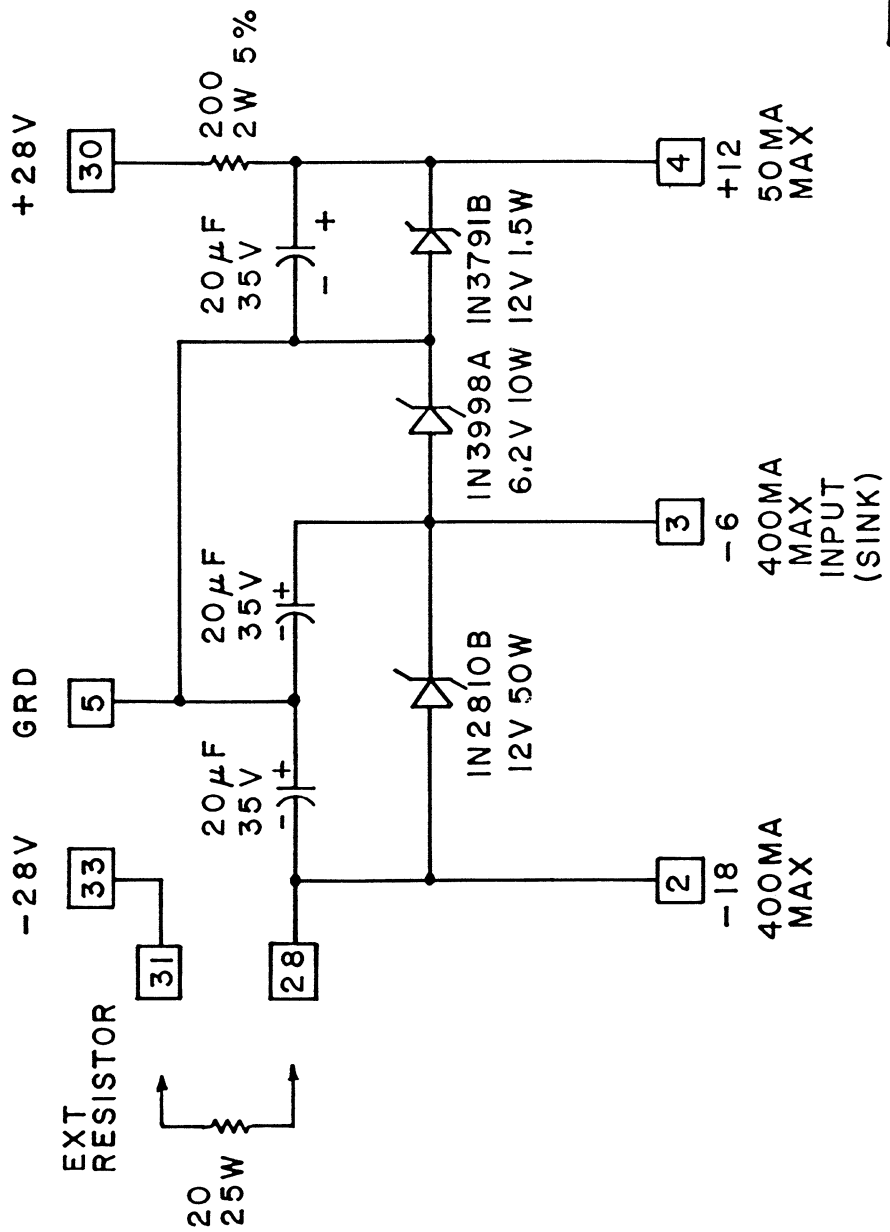

MOUNT IN2810B & IN3998A  
ON WAKEFIELD NC 621 HEAT SINKS

NATIONAL RADIO ASTRONOMY OBSERVATORY	
TITLE: STANDARD RECEIVER POWER SUPPLY MODULE	
DSGN. BY: S. WEINREB.	DATE: 2-12-66
APPD. BY:	DR. BY: A. J. MIANO.



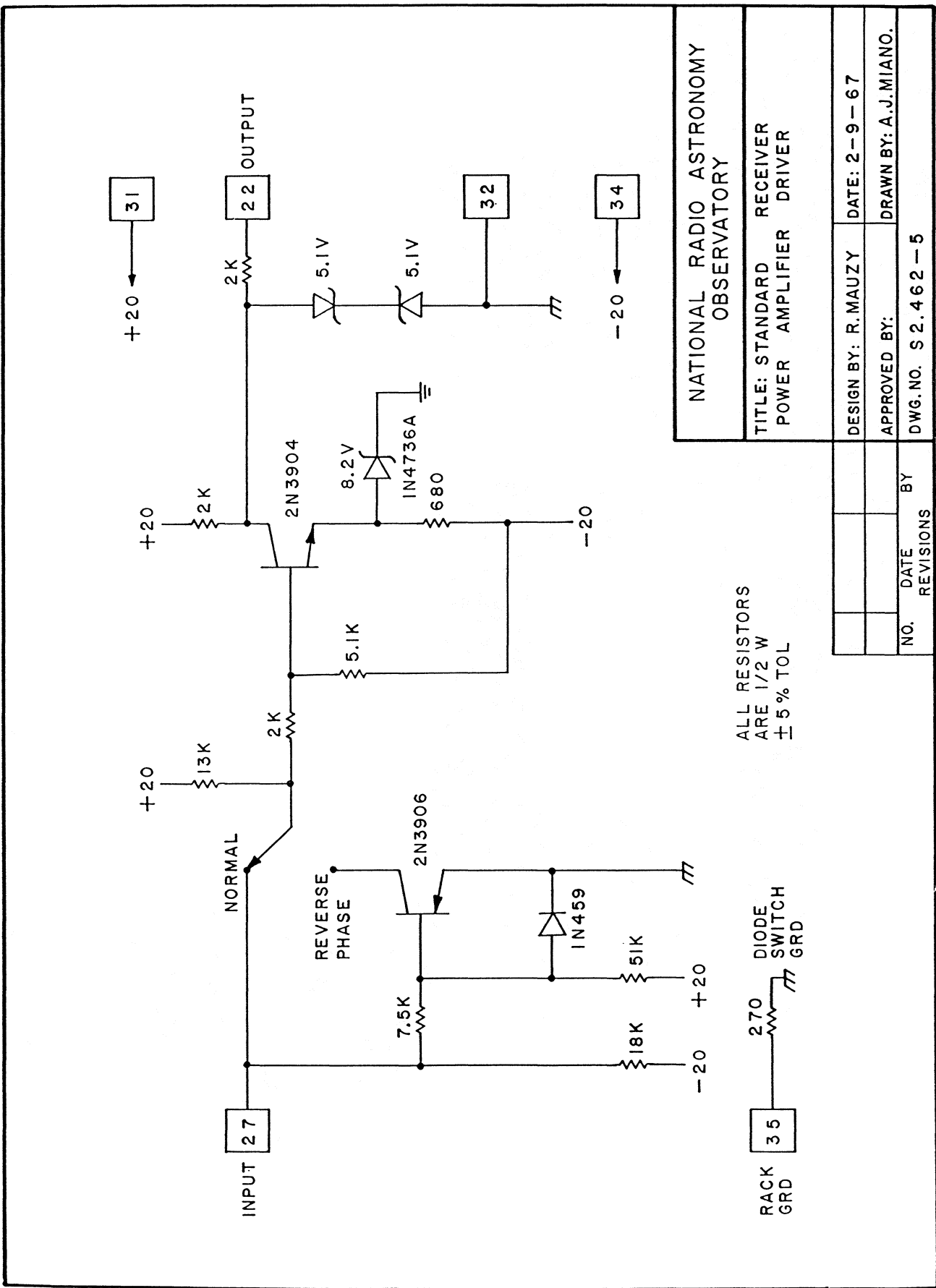

NATIONAL RADIO ASTRONOMY  
OBSERVATORY

TITLE: STANDARD RECEIVER  
POWER AMPLIFIER DRIVER

DESIGN BY: R. MAUZY      DATE: 2-9-67

APPROVED BY:              DRAWN BY: A.J. MIANO.

DWG. NO. S 2.462-5

ALL RESISTORS  
ARE 1/2 W  
± 5% TOL

NO.	DATE	BY

35 RACK DIODE SWITCH  
GRD GRD

270

31 +20

22 OUTPUT

2K

5.1V

5.1V

32

34 -20

2N3904

8.2V

IN4736A

680

5.1K

2N3906

7.5K

IN459

51K

13K

2K

2K

18K

270

S4 IS FERRITE SWITCH TYPE SELECTOR  
 CCW.-CENTER TAPPED SWITCH OR  
 MAGNETICALLY BIASED SWITCH  
 CW.-SINGLE COIL REVERSE CURRENT  
 SWITCH

NOTE: S-4 CTS-T-9  
 S-5 CTS-T-2  
 INDEX CTS-T-79  
 J-4 AMP 3102A-18-1P

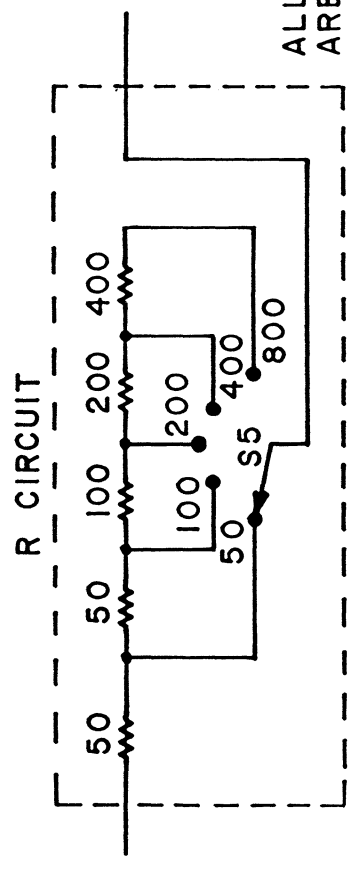
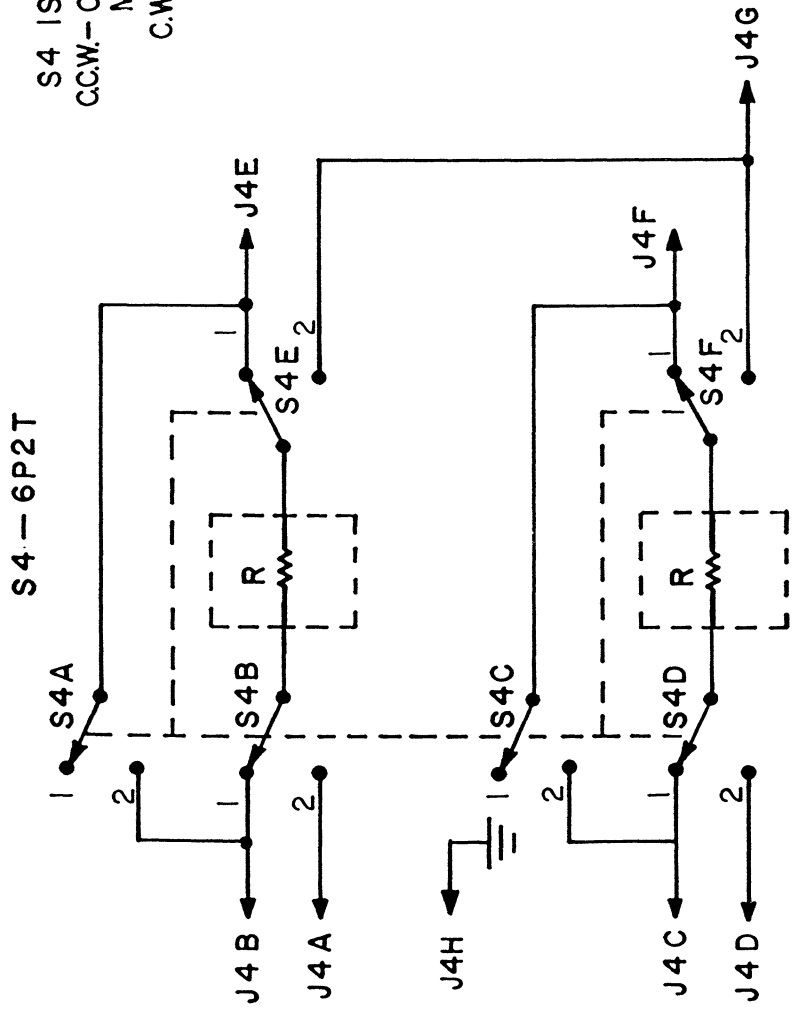

ALL RESISTORS  
 ARE DALE 50W-1%

FERRITE SWITCH LOAD RESISTOR  
 SELECTOR SWITCH S5 -2P5T

NATIONAL RADIO ASTRONOMY OBSERVATORY	
TITLE: STANDARD RECEIVER FERRITE SWITCH LOAD RESISTOR PLATE	
DSGN.BY: S.WEINREB	DATE: 2-9-67
APPD.BY:	DR.BY: A.J.MIANO
DWG.NO. S 2-462-6	

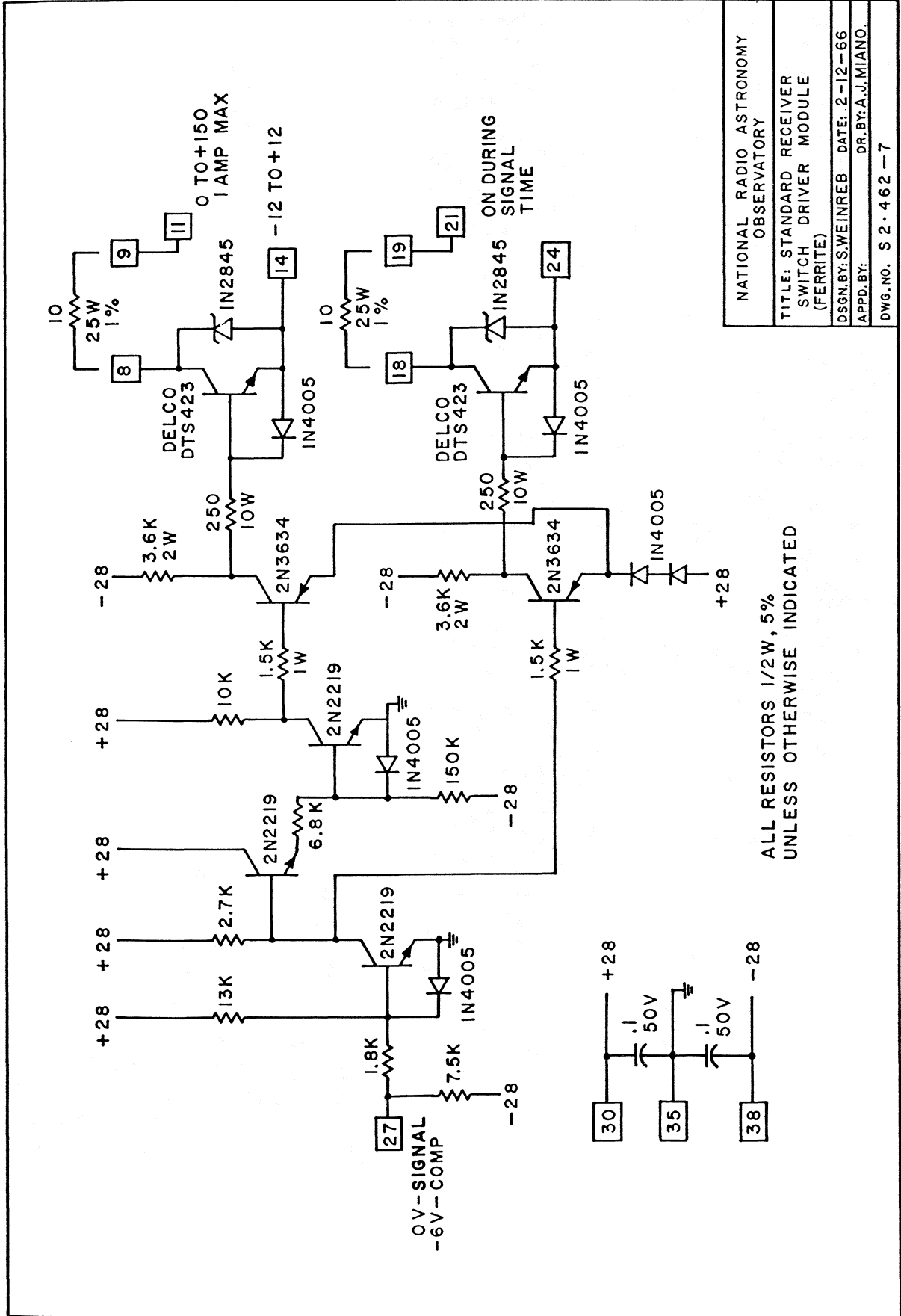

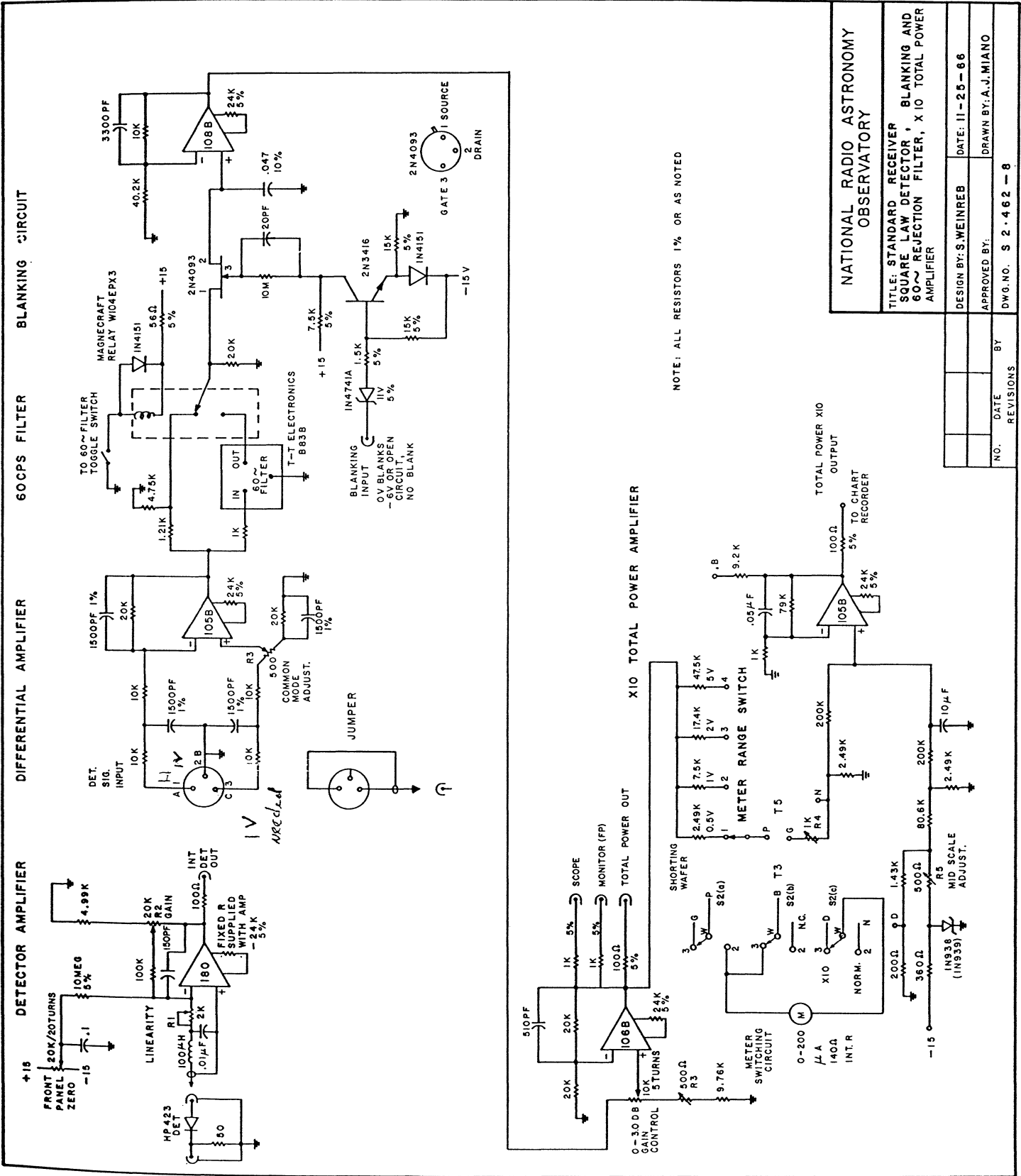

NOTE: ALL RESISTORS 1% OR AS NOTED

NATIONAL RADIO ASTRONOMY OBSERVATORY

TITLE: STANDARD RECEIVER, SQUARE LAW DETECTOR, BLANKING AND 60~ REJECTION FILTER, X10 TOTAL POWER AMPLIFIER

DESIGN BY: S. WEINREB DATE: 11-25-66

APPROVED BY: DRAWN BY: A. J. MIANO

NO.	DATE	BY	REVISIONS

DWG. NO. S 2-462-8

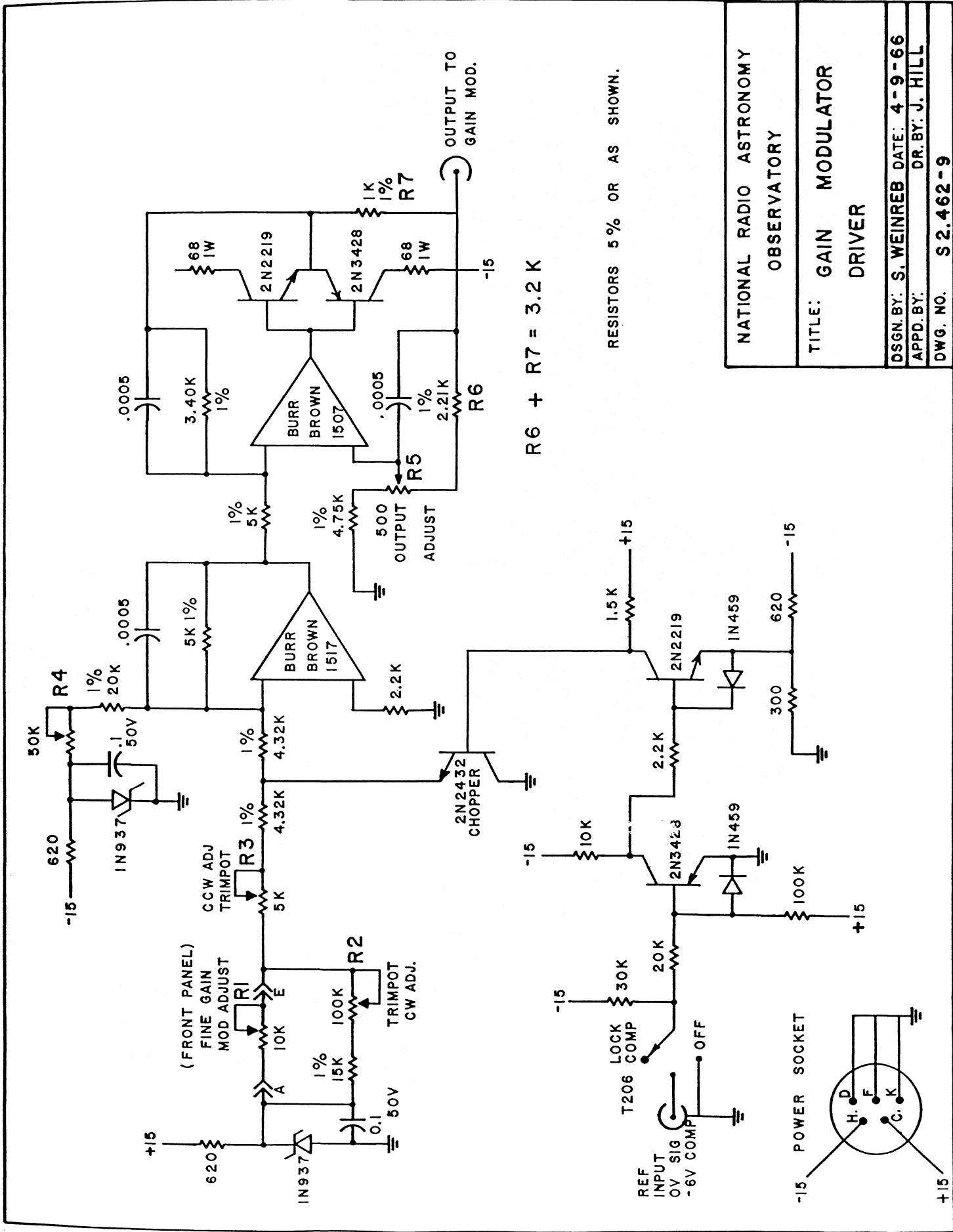

R6 + R7 = 3.2 K

RESISTORS 5% OR AS SHOWN.

NATIONAL RADIO ASTRONOMY  
OBSERVATORY

TITLE: GAIN MODULATOR  
DRIVER

DSGN. BY: S. WEINREB DATE: 4-9-66

APPD. BY: DR. BY: J. HILL

DWG. NO. S 2.462-9

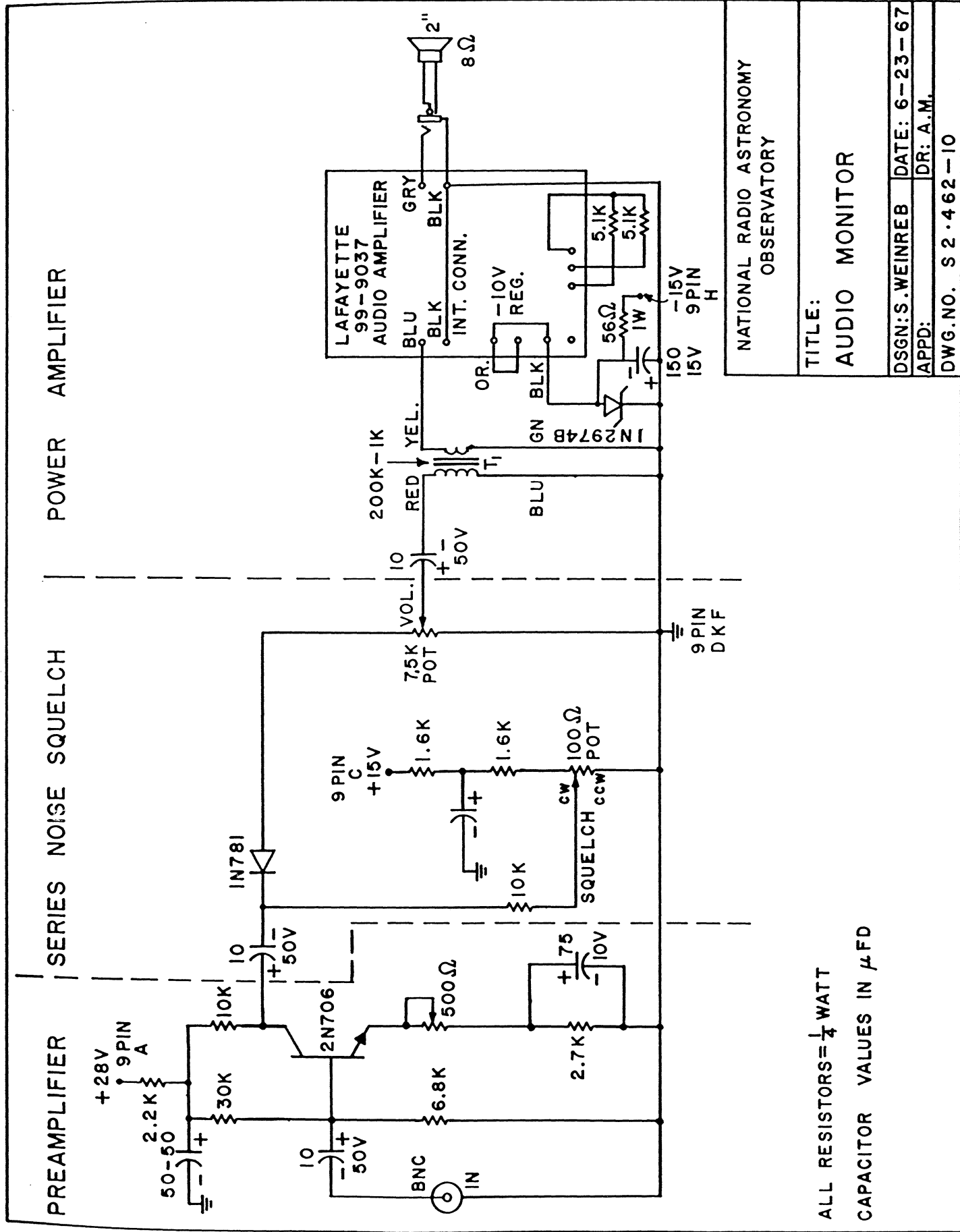

NATIONAL RADIO ASTRONOMY  
OBSERVATORY

TITLE:  
AUDIO MONITOR

DSGN: S. WEINREB    DATE: 6-23-67  
APPD:                    DR: A.M.  
DWG. NO. S 2.462-10

ALL RESISTORS = 1/4 WATT  
CAPACITOR VALUES IN μFD

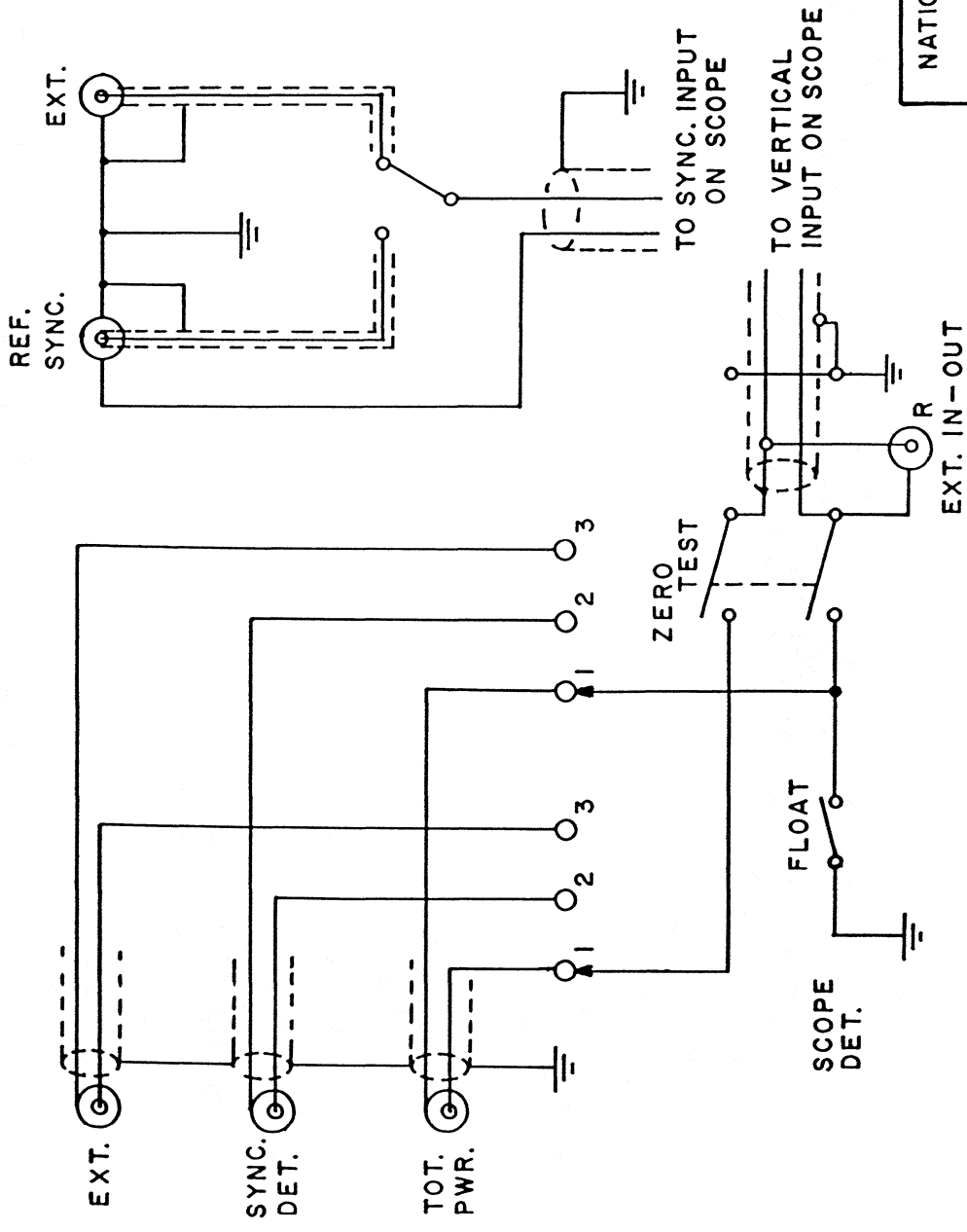

NATIONAL RADIO ASTRONOMY  
OBSERVATORY

TITLE: STANDARD RECEIVER  
SCOPE CONTROL PANEL  
WIRING

DSGN. BY: S. WEINREB | DATE: 6-23-67  
APPD. BY: | DR. BY: A. M.  
DWG. NO. S2-462-11

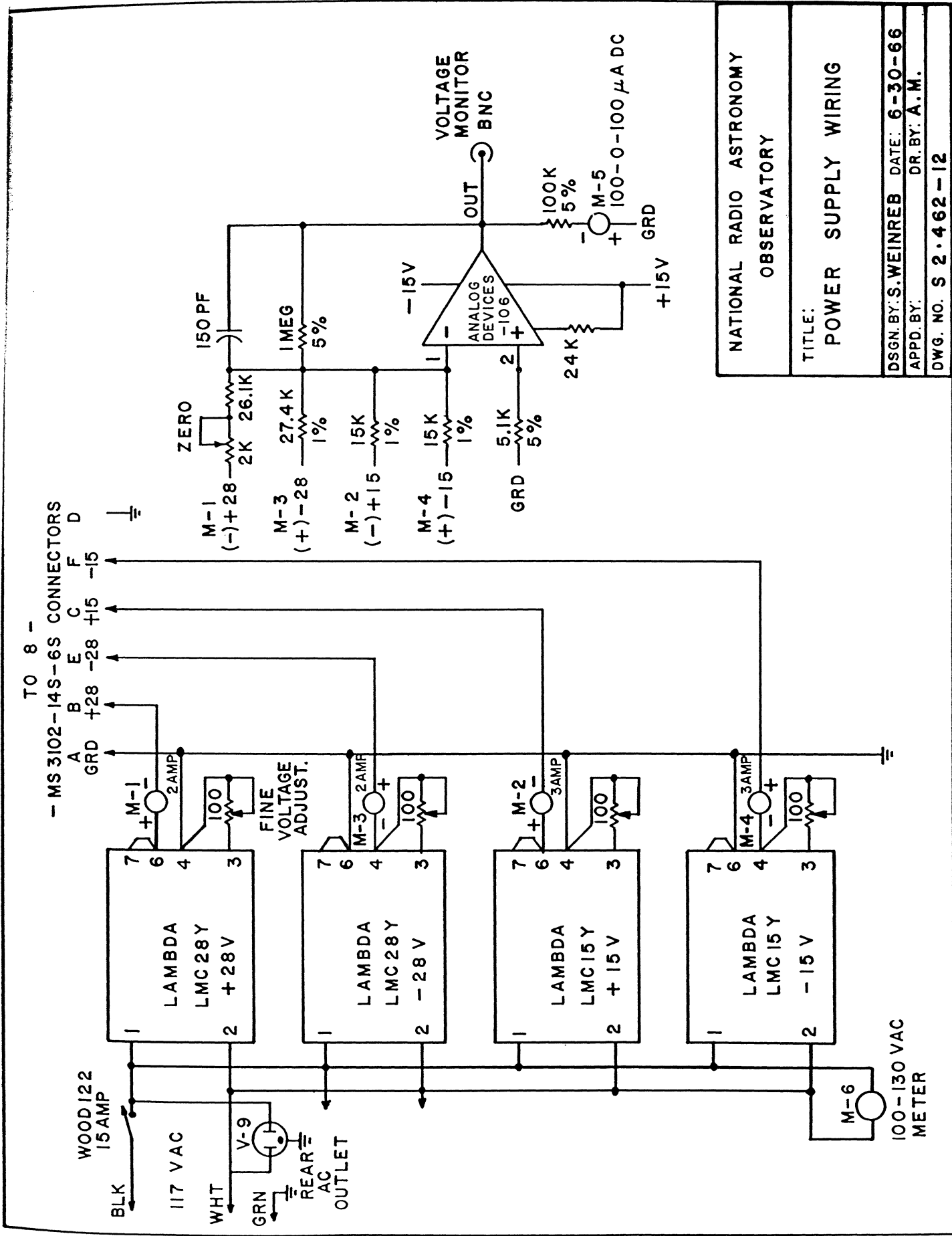

NATIONAL RADIO ASTRONOMY OBSERVATORY
TITLE: POWER SUPPLY WIRING
DSGN. BY: S. WEINREB DATE: 6-30-66
APPD. BY: A.M.
DWG. NO. S 2-462-12



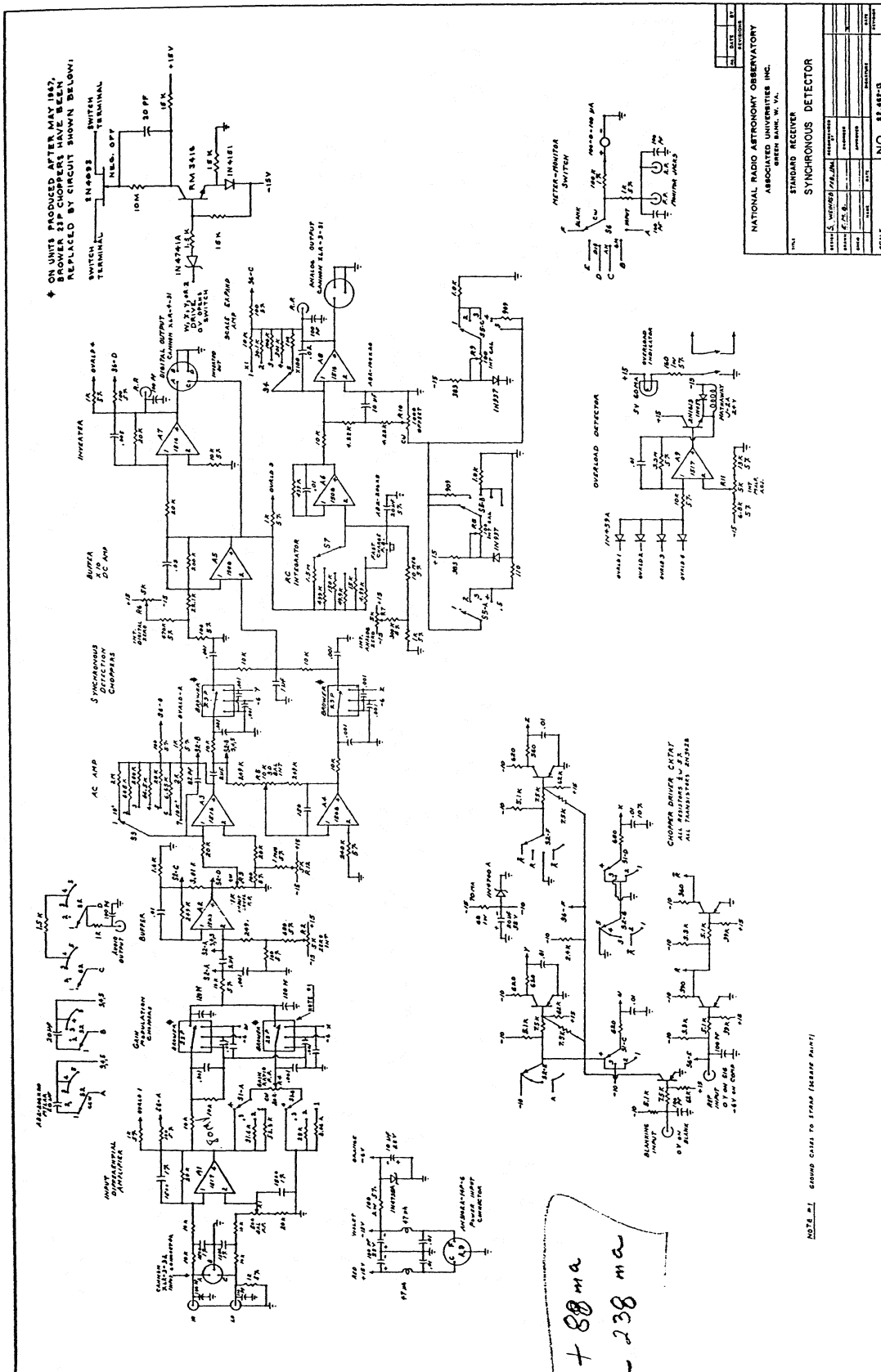

VI. Alignment Procedures

A. Square Law Detector Adjustment Procedure (See Figure 8.)

- 1) Set the AIL precision attenuator at 15.00 dB.
- 2) Set the Gain-Modulator and Square-Law Detector controls as follows:
 

1 DB STEPS .....	6 dB
0-3 DB .....	750
GAIN MODULATOR OPERATION .....	Off
METER-MID SCALE .....	5 V
NORMAL - X10 .....	Normal
- 3) Adjust the signal generator output level so that  $P_{IN}$  is -17 dBm (.02 mW) as read on a power meter.
- 4) Push the ZERO TEST push button and adjust the ZERO to within 1 mV of zero volts.
- 5) Set the linearity control, F1, at minimum resistance.
- 6) Adjust the interval detector gain (R2, a 20 K pot) so that the digital voltmeter reads 1.000 volts.
- 7) Note the output voltage when the attenuator is set to 12.00 dB. The correct value should be 1.995. If the meter reading is above this amount, increase R1 and repeat steps 6 and 7 until a reading between 1.985 and 2.005 is achieved. If the meter reading is below 1.985 with R1 at minimum resistance then the detector can probably not be used.
- 8) Measure the output voltage for the following attenuator settings; the correct values are also noted below. The ZERO should be checked during this procedure.

(continued on page 34) --

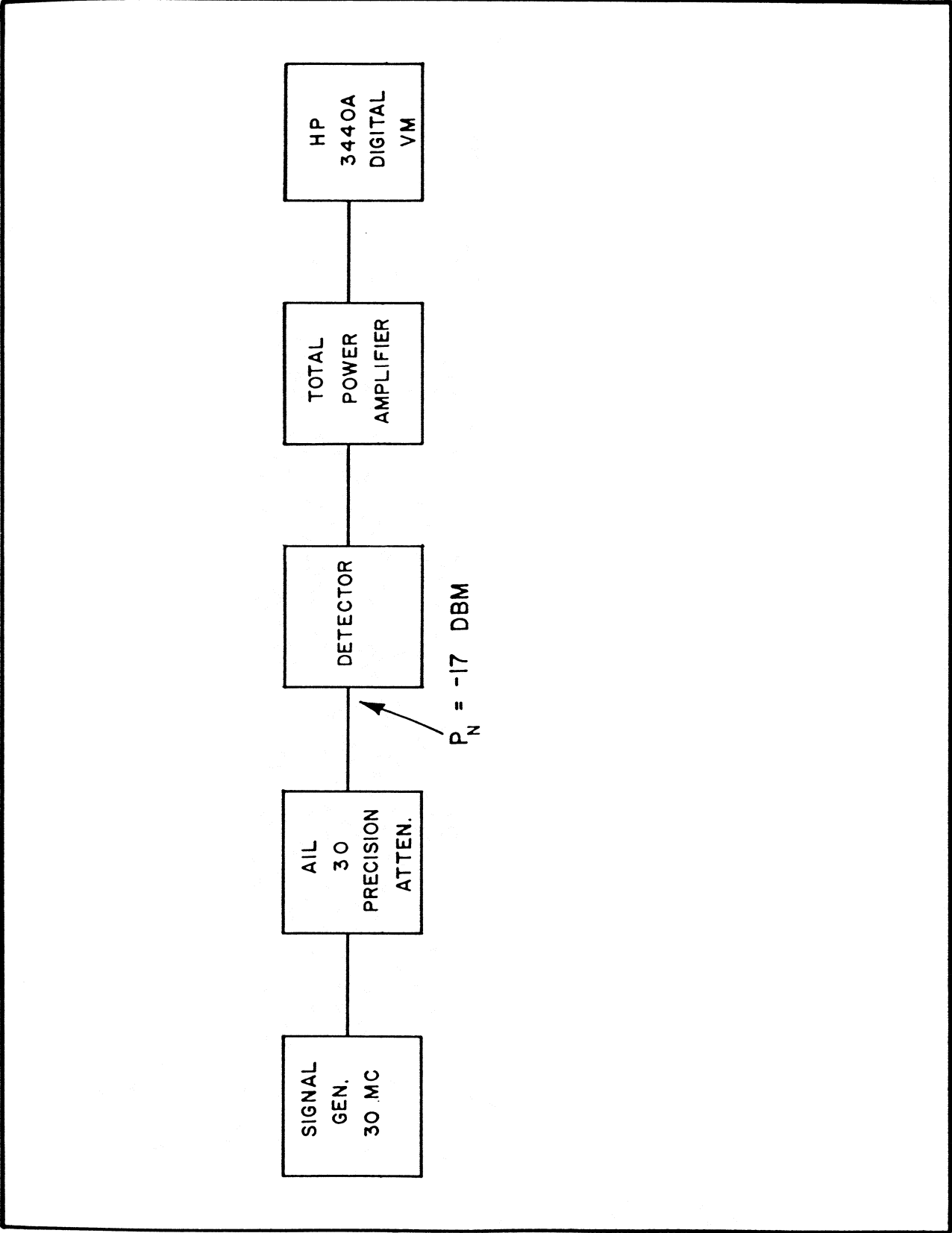

Figure 8 — Square Law Detector Adjustment Procedure

<u>AIL Attenuator Setting</u>	<u>Correct Output Voltage</u>
21	0.251
18	0.501
17	0.631
16	0.794
15	1.000
14	1.259
13	1.585
12	1.995
10	3.162
9	3.981
8	5.012
7	6.310
6	7.943
5	10.000

- 9) The error is defined as:

$$100\% \frac{\text{READING} - \text{CORRECT VALUE}}{\text{CORRECT VALUE}}$$

This should be plotted for the values in the preceding table. An acceptable detector must have less than  $\pm 2\%$  error for output voltages of 0.50 volts to 4.0 volts. A typical error curve is attached.

- 10) Switch the oscilloscope to TOTAL POWER and set the VERTICAL SENSITIVITY to 2 mV/cm (AC coupled), HORIZONTAL at X1, and SWEEP at 5 ms/cm. The peak-to-peak noise should be less than 3 mV; the actual value should be recorded. If the noise is above 4 mV, repeat the entire procedure with -15 dBm in step 3. This will reduce the noise by 0.6. If the noise is low but the detector error is too high at large output voltages, repeat the procedure with -20 dBm in step 3.

- 11) With the meter reading exactly mid-scale, the mid-scale adjustment, R5, should be set so no change takes place in the meter reading when switching from NORMAL to X10.
- 12) The meter substitution pot, R4, should be adjusted so there is no change in the voltage out of the X10 SCALE EXPAND output jack when switching from NORMAL to X10.

#### B. Gain Modulator Driver Adjustment Procedure

##### R5 Output Impedance Adjustment

- 1) Connect output of gain modulator driver to input on test box.
- 2) Connect output of test box to digital voltmeter.
- 3) Adjust R5 so voltage reading on DVM does not change when pot on test box is turned full range.

##### R1, R2, R3, R4 Adjustment

- 4) Reconnect gain modulator driver to gain modulator.
- 5) Connect signal generator to SIGNAL INPUT on back of gain modulator-square law detector chassis. Frequency should be between 2 and 300 MHz (30 MHz is a good point).
- 6) Connect reference generator to REF INPUT and power plug to back of box.
- 7) Adjust input level from signal generator with gain controls set at mid-range so that total power output meter reads approximately 1 volt.
- 8) Connect oscilloscope with 423A detector to output of wideband amplifier.
- 9) If negative type detector (such as 423A) is used, connect it to DC inverted input on scope; in order that the following directions apply, check to see that removal of input signal causes scope beam to drop.
- 10) Set scope vertical sensitivity to 1 mV per cm, time base to .5 m sec per cm and reference generator to 400 cps.
- 11) Set IF gain modulator coarse gain ratio knob on 3 dB.
- 12) Set fine gain ratio dial (R1) to read 500.

- 13) If step 9 is observed, it will be noted that increasing attenuation with coarse gain ratio knob will shift comparison channel downward. Set coarse gain ratio knob back to 3 dB and adjust R4 so that signal and comparison channels are balanced, i. e. , they form a straight line on the scope.
- 14) Now move R1 (fine gain ratio dial) to 0, then to 1000. This shifts comparison above and below signal channel. When R2 and R3 are properly adjusted, R1 should shift comparison channel approximately .7 dB above and below signal channel. (This .7 dB can be estimated by using a 1 dB step by means of the coarse gain ratio knob for comparison.)

15) The following chart should facilitate adjustment of R2 and R3:

a) Set R1 at 500 each time before readjusting.

b)

R2		R3	
CW	CCW	CW	CCW
Reduces attenuation on lower side of signal channel more than on upper side.	Increases attenuation of lower side more than upper.	Reduces attenuation of lower side only.	Increases attenuation of lower side only.

- c) After adjusting R2 and/or R3, balance comparison and signal with R4.
- d) Repeat step 14.
- e) If driver is not properly adjusted, repeat steps 15 a-d.
- 16) If, due to a difference in characteristics of the PIN diodes in the gain modulator, the attenuation range of the comparison channel is too great or too small and cannot be compensated for by adjusting R2 and R3, then it may be necessary to change R7.

16) continued --

- a) If the attenuation range is too small (< .6 dB either side), then increase the value of R7; if attenuation range is too large (> .8 dB either side), then decrease R7. (Resistance must be changed by 20-30% to be significant.)
- b) After the proper value of R7 has been determined, R6 must be changed in order that R5 has enough range to properly adjust the output impedance. The value of R6 is determined by the relation:

$$R6 = 3.2 K - R7$$

- c) After R6 and R7 have been changed, readjust output impedance according to steps 1-3.

### C. Synchronous Detector Adjustment Procedure

Equipment Required: Tektronix 502 Scope  
HP 412 VTVM  
HP Digital VM or Fluke Differential VM  
Input Test Box  
Reference Generator

Initial Control Settings: Gain Modulator — Off  
Gain Ratio — 600  
Mode — Synchronous Detector > 10 Hz  
Input Level — 000  
Monitor — Input  
Full Scale — 10 degrees  
Scale Expand — X1  
Offset Switch — Off  
Offset Control — 250  
Time Constant — 0.1 sec.

- 1) Mechanically zero meter pointer.
- 2) Adjust +15 and -15 volt power supplies to within .05% of 15.00 volts.

- 3) Connect input test box and ~~return~~ turn on AC common mode signal and DC radiometer simulation signal. Connect the scope (1 mV/cm - AC, 5 ms/cm, line sync) to the monitor jack. Adjust the balance pot, R1, for a minimum of 60 Hz deflection. The 60 Hz component should be under 1 mV peak to peak. Turn off 60 Hz source.
- 4) Connect the HP digital VM or HP 412 VTVM to the monitor jack and turn the monitor switch to GM out. Adjust R 12 for a zero reading (within  $\pm 2$  mV from zero). Turn up the input level control to 1000 and adjust R2 for a zero reading.
- 5) Turn the monitor switch to dig out and the full scale switch to 10 K. Adjust R6 for a zero reading on the VM (still connected to the monitor jack).
- 6) Turn the monitor switch to analog out and adjust R7 for a zero reading.
- 7) Turn the offset switch to move left — high. Adjust R8 so that VM reads -2.500 volts. Turn the offset switch to move right — high. Adjust R9 so that the VM reads +2.500 volts. Turn the offset switch to off.
- 8) Turn the monitor switch to dig out, the full scale switch to 100°, and the gain modulator switch to .7-1.2 range. Adjust the front panel gain ratio control so that the VM reads +10.0 volts. Now turn R11 so that the overload light just turns on.
- 9) Turn the gain modulator switch back to off and connect a 3.0 meg 5% resistor from +15 volts to point, S2-B pos 3, 4, 5. Adjust R5 so that the VM reads zero. Disconnect the resistor.



D. Synchronous Detector Noise Test

- Equipment Required:      Chart Recorder having  $\pm 10$  V full scale  
                                   Input Test Box  
                                   Reference Generator
- Initial Control Settings: Gain Modulator — Off  
                                   Gain Ratio — 1000  
                                   Mode — Synchronous Detector 10 Hz.  
                                   Input Level — 1000  
                                   Monitor — Analog Output  
                                   Full Scale — 10 degrees  
                                   Scale Expand — X100  
                                   Offset Switch — Off  
                                   Offset Control — 1000  
                                   Time Constant — 1 second

- 1) The noise fluctuations on the front panel meter should be observed for reference frequencies of 1, 10, 50, and 400 cps and for input level settings of 100 and 1000. The fluctuations should be within the following limits:

Maximum Synchronous Detector Noise Fluctuations

Reference Frequency	Input Level = 1000	Input Level = 100
1 cps .....	$\pm 40$	$\pm 5$
10 cps .....	$\pm 2$	$\pm 1$
50 cps .....	$\pm 1$	$\pm 1$
400 cps .....	$\pm 1$	$\pm 1$

(Units are meter microamps, 1 meter microamp = .001  $\text{°K}$  = 100 mV.)

It may be necessary to zero the meter with the offset controls at higher reference frequencies.

D. (continued) --

- 2) Turn the gain modulator switch to the .7 to 1.2 range and the offset switch to move left high. Adjust the gain ratio control so that the meter is near mid-scale (very sensitive adjustment). The fluctuations should be less than those indicated in the above table. A re-adjustment of the gain ratio pot will be necessary when the input level is changed from 100 to 1000.