

NATIONAL RADIO ASTRONOMY OBSERVATORY
Green Bank, West Virginia

Electronics Division Internal Report No. 86

DRIVER FOR 300-FOOT
TRAVELING FEED TRANSLATOR

Ronald B. Weimer

JUNE 1969

NUMBER OF COPIES: 100

DRIVER FOR 300-FOOT TRAVELING FEED TRANSLATOR

Ronald B. Weimer

- 1) A versatile drive system was required to operate the stepping motor on the traveling feed at the 300-foot telescope. A block diagram of the system constructed is shown in Figure 1.
- 2) A free-running multivibrator (FRMV) is used to slew the traveling feed from one position to another. The motor can respond to up to 500 steps per second. The FRMV was designed to operate between 70 and 500 Hz. A control on the front panel adjusts this rate. A schematic for the FRMV is shown in Figure 2.
- 3) The pulse shaper input must accept outputs from either the FRMV or the Beckman Timing Interval Generator (TIG). A considerable amount of noise was found on the TIG signal so the input circuit is designed to reject any signals less than about 2 volts. A schematic for the Pulse Shaper is shown in Figure 3. Transistor Q4 provides the inhibit operation. Transistors Q5, Q6 and Q7 form a 100 μ s one-shot multivibrator. Transistors Q8 and Q9 provide output isolation and drive required for the long cable to the translator located at the focal point.
- 4) The automatic start circuit accepts a momentary contact closure and latches into a run condition. The circuit is reset and held in a stop condition when the mode switch is in "OFF" or "MANUAL" position. A schematic of the automatic start circuit is shown in Figure 4. The 0.22 μ F capacitor provides a 1 millisecond time constant on the start contact input. This should reduce the possibility of false starts due to noise pickup on this input line. Transistors Q10, Q11, Q12, and Q13 form a flip-flop which latches up on the contact closure or when the mode switch is in "OFF" or "MANUAL" position. Transistor Q14 isolates the flip-flop output and drives the mode switch.
- 5) An Analog Devices model 901 power supply is used. The current drain is just under 40 mA, which is the rating of the power supply. If the circuit grows much more, the model 902 power supply (100 mA rating) should be substituted.
- 6) Typical waveform for the FRMV and Pulse Shaper are shown in Figures 5 and 6.

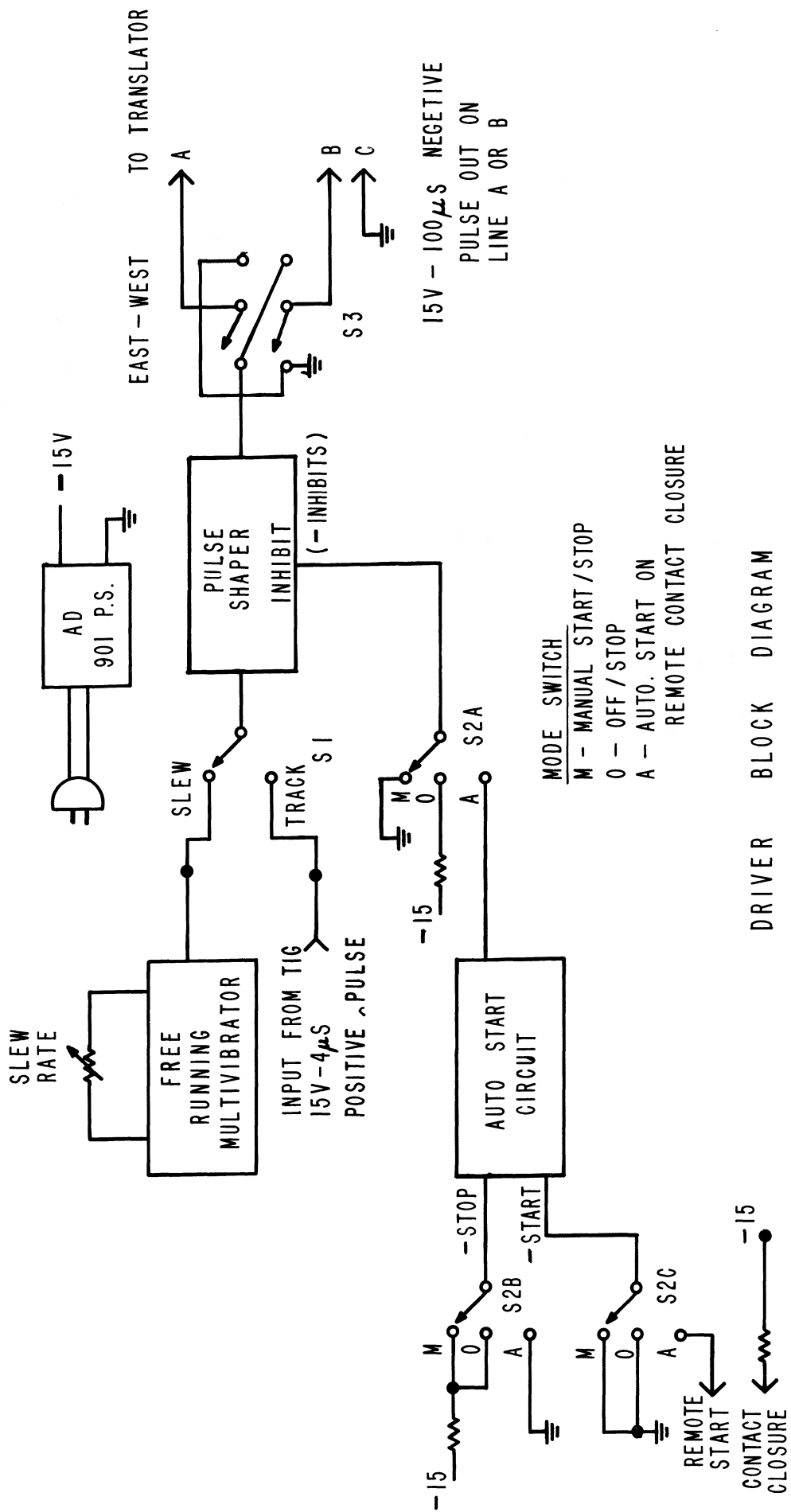

DRIVER BLOCK DIAGRAM
FIG. 1

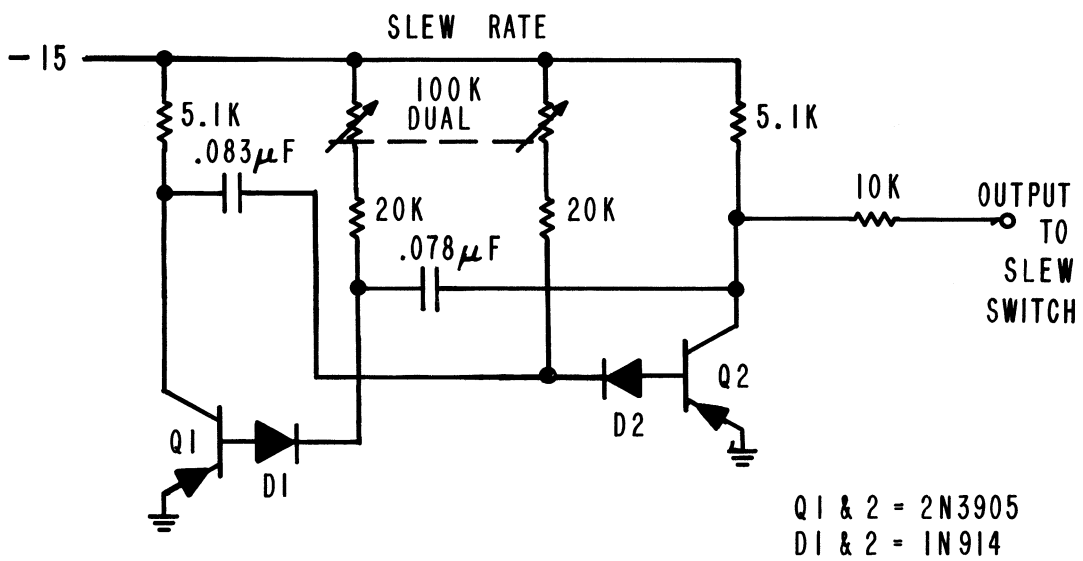

FREE RUNNING MULTIVIBRATOR
FIG. 2

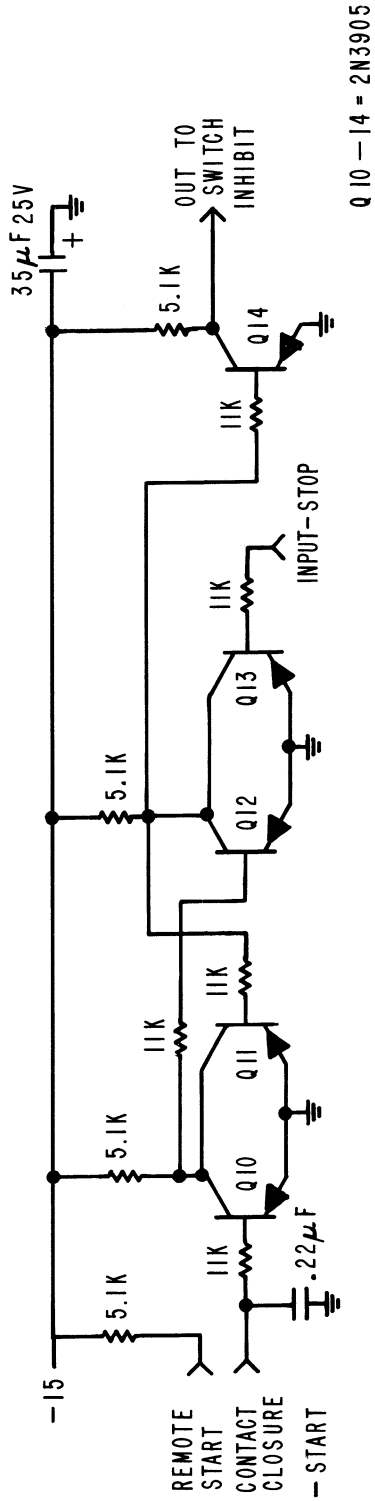

Q 10 - 14 = 2N3905

FIG. 4
AUTOMATIC START CIRCUIT

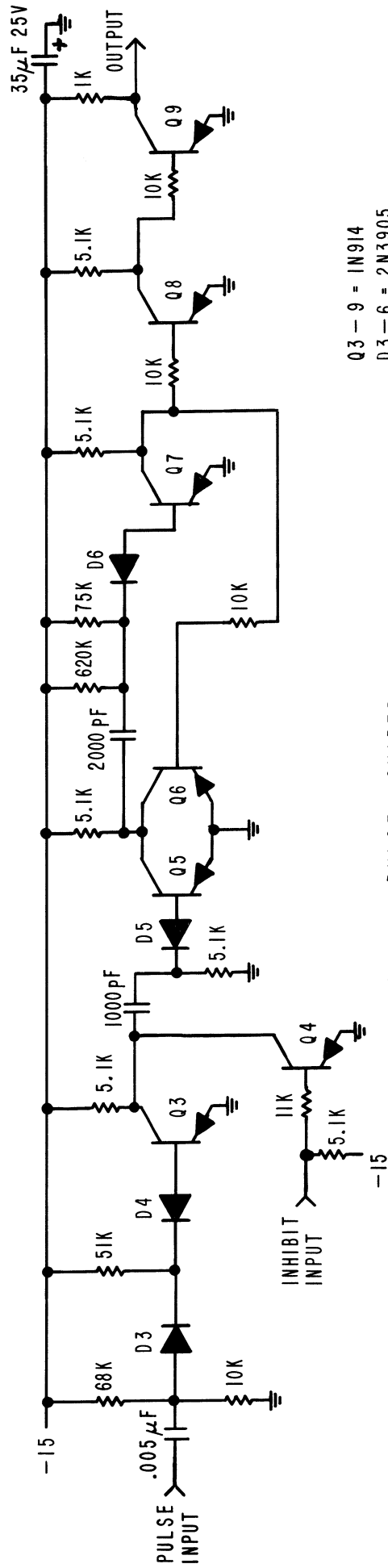

Q3 - 9 = 1N914
D3 - 6 = 2N3905

FIG. 3
PULSE SHAPER

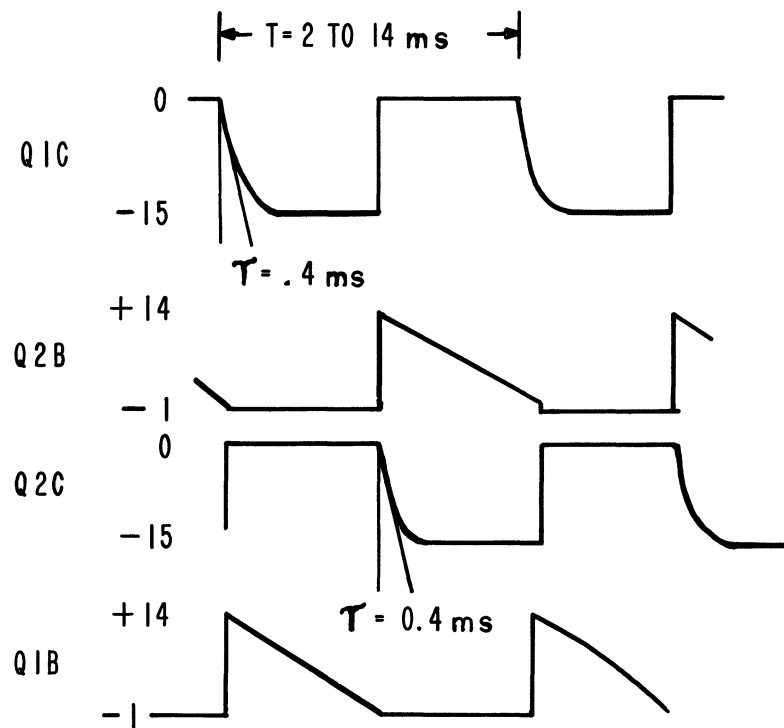

FREE RUNNING MULTIVIBRATOR
WAVEFORMS

FIG. 5

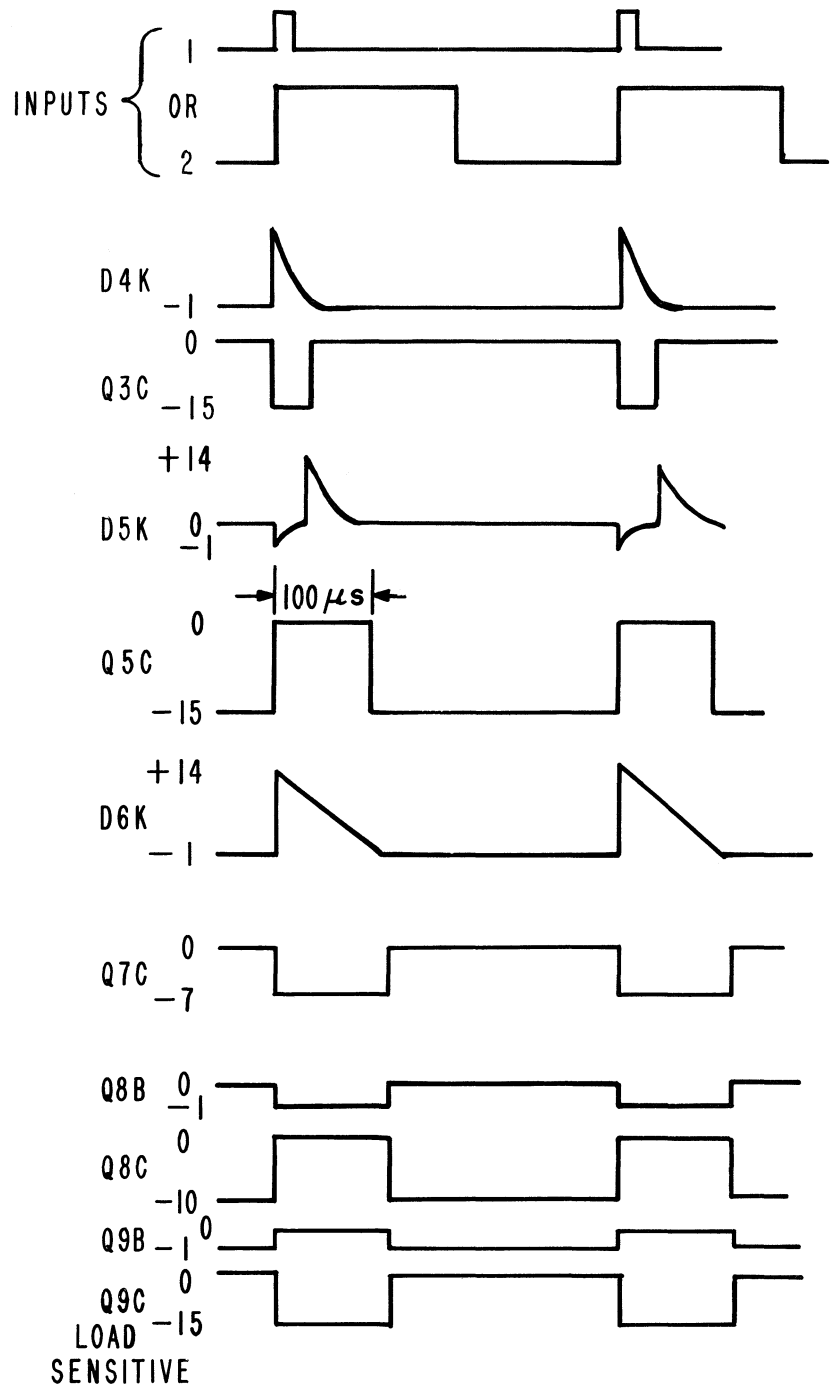

PULSE SHAPER
WAVEFORMS
FIG. 6