

NATIONAL RADIO ASTRONOMY OBSERVATORY
Green Bank, West Virginia

Electronics Division Internal Report No. 50

INTERFEROMETER FRONT END SYSTEMS
USING TWO PARAMETRIC AMPLIFIERS

Bernard Pasternak

NOVEMBER 1965

NUMBER OF COPIES: 75

**INTERFEROMETER FRONT-END SYSTEMS
USING TWO PARAMETRIC AMPLIFIERS**

Bernark Pasternak

TABLE OF CONTENTS

| | <u>Page</u> |
|---|-------------|
| Introduction ----- | 3 |
| General Description ----- | 3 |
| AIL Paramp ----- | 3 |
| AIL Modification ----- | 3 |
| MPC Paramp ----- | 4 |
| MPC Modifications ----- | 4 |
| Mixer Preamp ----- | 4 |
| Main IF Amp ----- | 5 |
| Dicke Receiver ----- | 5 |
| Bias Filter ----- | 6 |
| Noise Tube Calibration ----- | 6 |
| Temperature Control ----- | 6 |
| Polarization and Focusing ----- | 7 |
| Frequency Multiplier ----- | 7 |
| Front-End Equipment | |
| 85-1 Telescope Front End ----- | 8 |
| 85-2 Telescope Front End ----- | 8 |
| Equipment Specifications | |
| TRG Scalar Feed ----- | 9 |
| RHG Mixer-Preamp ----- | 9 |
| H-P Main IF Amplifier ----- | 10 |
| Laboratory Measurements | |
| 85-1 Front End Equipment ----- | 10 |
| 85-2 Front End Equipment ----- | 11 |
| AIL Paramp Bias Calibration 85-1 ----- | 12 |
| AIL Paramp Bias Calibration 85-2 ----- | 12 |
| Telescope Measurements | |
| 85-1 Telescope Front End ----- | 12 |
| 85-2 Telescope Front End ----- | 13 |
| Maintenance ----- | 13 |
| Access to the Front End Equipment ----- | 15 |
| Noise Temperature Measurements ----- | 15 |
| Discussion ----- | 16 |

Figure

Diagrams

| | |
|--|----|
| Control Room Cabling ----- | 1 |
| Telescope Cabling ----- | 2 |
| 18 Conductor Tee Box Terminal ----- | 3 |
| 11 Conductor Tee Box Terminal ----- | 4 |
| Heater-Cooler Wiring ----- | 5 |
| Tee Box Connector Layout ----- | 6 |
| Tee Box Component Layout ----- | 7 |
| AIL Paramp Block Diagram ----- | 8 |
| MPC Paramp Block Diagram ----- | 9 |
| 85-1 Front End Block Diagram ----- | 10 |
| 85-2 Front End Block Diagram ----- | 11 |
| 85-1 Dicke Receiver Front End ----- | 12 |
| 85-2 Dicke Receiver Front End ----- | 13 |
| Test Equipment Arrangement for Gain-Bandpass at Telescope ----- | 14 |

Schematics

| | |
|--|----|
| Noise Tube Power Supply ----- | 15 |
| Noise Tube Firing Box ----- | 16 |
| IF Bandpass Filter ----- | 17 |
| AIL Paramp Bias Supply ----- | 18 |
| AIL Paramp Bias Filter ----- | 19 |
| Focusing and Polarization Control Unit ----- | 20 |
| Focusing and Polarization Drive Unit ----- | 21 |
| Focusing Syncro Layout ----- | 22 |

Graph

| | |
|---------------------------|----|
| Typical Scalar Feed ----- | 23 |
|---------------------------|----|

Photographs

| | |
|--|----|
| 85-1 Telescope Front End ----- | |
| Gain-Bandpass Mixer-Preamp ----- | 24 |
| Gain-Bandpass Main IF ----- | 25 |
| Gain-Bandpass AIL Parametric Amplifier ----- | 26 |
| Gain-Bandpass MPC Parametric Amplifier ----- | 27 |
| System Gain-Bandpass ----- | 28 |
| 85-2 Telescope Front End | |
| Gain-Bandpass Mixer Preamp ----- | 29 |
| Gain-Bandpass Main IF ----- | 30 |
| Gain-Bandpass AIL Parametric Amplifier ----- | 31 |
| Gain-Bandpass MPC Parametric Amplifier ----- | 32 |
| System Gain-Bandpass ----- | 33 |
| AIL Parametric Amplifier Before Modification ----- | 34 |
| AIL Parametric Amplifier After Modification ----- | 35 |
| MPC Parametric Amplifier After Modification ----- | 36 |

INTRODUCTION

The purpose of this report is to give an understanding of the capabilities of the interferometer front end equipment and includes information necessary for proper maintenance. The description of the components is necessarily brief and reference should be made to the manufacturers' instruction manuals. The schematics shown in this report are limited to equipment constructed at NRAO. The gain bandpass data given under LABORATORY MEASUREMENTS should be regarded as final measurements and may not agree with the manufacturers' ratings.

GENERAL DESCRIPTION

AIL Parametric Amplifier

The AIL Model 4044 parametric amplifier is a one-port, non-degenerate amplifier using a 4-port circulator with waveguide input and coaxial output. The amplifier operates with a 1 dB bandwidth of approximately 40 MHz and a gain of 15 dB. The noise figure is approximately 75 °K.

The pump operates at 27.5 GHz utilizing a Varian 283G klystron. The DC supply voltages and the DC heater voltages are provided by a Hewlett-Packard klystron power supply, Model 716B, located in the control room. Beam voltage of 800 volts at approximately 30 mA is required.

The varactor bias is obtained from an adjustable mercury battery supply located in the control room. The amplifier uses a Microwave Associates silicon varactor, Type MA 4539. Specifications for this varactor are given in the AIL paramp instruction manual. The amplifier will tune at $2695 \text{ MHz} \pm 200 \text{ MHz}$ by adjusting the signal tuner and bias voltage.

Modifications of AIL Parametric Amplifier

The mechanical configuration of the amplifier was not suitable for use in the tee box. Refer to the photographs in this report showing the amplifier before and after modification. The original pump attenuator was replaced by a TRG variable waveguide attenuator, which proved to be more stable. The pump tuner, which consisted of a section of waveguide with tuning screws, was replaced by an FXR E- and

H-plane, micrometer-adjustable, tuner. The bias supply was removed from the paramp chassis and installed in the control room to provide remote tuning of the amplifier.

MPC Parametric Amplifier

The MPC Model S-15 is a nondegenerate one-port amplifier using a 4-port circulator with type N input and output connectors. The amplifier operates with a minimum bandwidth of 30 MHz centered at 2695 MHz with a gain of 20 dB. Bandwidths of approximately 100 MHz at 15 dB gain were attained in the lab.

The pump operates at 13.3 GHz using a Varian V246A klystron. The DC supply voltages for the klystron are provided by an MPC klystron power supply located in the control room. Beam voltage of 500 volts at approximately 40 mA is required.

No external bias supply is required since this amplifier uses self bias. Noise figure measurements of 180 °K were achieved with most stable operation at zero bias.

Modification of MPC Parametric Amplifier

An MTI isolator was installed in the pump circuit to prevent klystron frequency pulling. A Waveline E- and H-plane tuner was installed at the pump input to the varactor mount to provide a better match. These additions improved the stability considerably. The bias pot was removed from the amplifier and a DC short was substituted in its place, since the amplifier operated best with zero bias. An Omega detector was installed at the pump monitor to provide monitoring of the pump power at the control room. The detector is isolated from the paramp chassis with a Teflon spacer and nylon screws.

Mixer Preamp

The RHG mixer preamp consists of a Sage balanced mixer using a matched pair of 1N21E and 1N21ER crystals, followed by three stages of solid state amplification. An external DC supply of 30 volts is provided by a Kepco power supply

located in the control room.

The local oscillator input to the mixer is fed from a solid state frequency doubler thru a 10 dB fixed attenuator. The RF input is fed from the output of the MPC paramp thru a Sperry 3-port circulator. The unused port is terminated with a Microlab 50 ohm termination. The IF output is coupled to the main IF amplifier thru a bandpass filter (1 MHz - 20 MHz). This filter is provided with a 10 dB fixed attenuator which may be switched in or out of the circuit as required to prevent saturation of the main IF. Laboratory tests proved that the attenuator was not necessary when using the Hewlett-Packard 462A amplifier; therefore, the attenuator is not used during normal operation.

Main IF Amplifier

The Hewlett-Packard Model 462A is a solid state, resistance-capacitance coupled wideband amplifier with a series regulated DC power supply. A zener diode provides reference voltage for the supply. A gain control switch is provided to select gains of 20 or 40 dB with a maximum output of 1 V p-p into 50 ohms. In normal operation 40 dB gain is used. The AC line voltage is supplied from the AC regulator located in the control room.

Dicke Switched Receiver

The interferometer total power front end can be used as a switched receiver with the addition of a diode switch and a comparison load. Since access to the input of the first parametric amplifier (AIL) is not possible due to the waveguide input, the switch must be inserted at the input of the MPC paramp. The AIL paramp is turned off during this mode of operation and the paramp bias cables are used for the switch drive voltage. The signal path is through the AIL paramp circulator with approximately 2 dB insertion loss. Extreme caution should be observed when changing from switched receiver to total power receiver to avoid possible damage to the varactor due to the switch drive voltages. Also, polarity of the bias cables must be correct when changing back to total power system. Refer to the cabling list in this report before attempting to change the mode of operation.

Bias Filter

The bias filter is a resistance-capacitance low-pass filter designed to minimize the effects of ground loops and spike voltages on the operation of the AIL par-amp. This filter was considered necessary for remote operation of the varactor bias. The bias supply is located in the control room and is isolated from ground. Both the positive and negative leads use the center conductor of RG 9/U cables. The positive lead is connected to the paramp chassis in the tee box.

Bias Supply

The bias supply consists of two mercury batteries paralleled with a 100 K helipot. The output voltage is taken from the center-tap of the pot thru a 1.5 K resistor, and the positive terminal of the battery. Calibration curves of the paramp center frequency as a function of bias were plotted for each system. These curves were checked after installation at the telescope and new curves were plotted on the calibration chart to show the difference between laboratory measurements and field measurements.

Noise Tube Calibration

The calibration system utilizes an AIL coaxial noise tube mount, Model 7012, with a Bendix, Model TD 92, noise tube. The output of the noise tube is fed thru a 5 dB fixed attenuator and the 20 dB arm of the waveguide cross coupler. The calibration signal is approximately 30 °K. The exact value for each system was determined from accurately known sources and is given elsewhere in this report. The high voltage firing box is located in the pillbox and the power supply is located in the control room. Remote control of both system calibrations is available at the trailer.

Temperature Control

The tee box temperature is automatically controlled using eight solid state heat pumps mounted on each tee box. Two Ohio Semiconductors, Model TU-6F, are mounted at the center of the tee box arms and six Westinghouse, Type W832G02,

units are mounted on the tee box body. All units are series connected and power is provided by a Harrison Labs, Model 520A, DC power supply capable of supplying 0-25 amps at 0-36 volts.

The automatic cooling system is described in Electronics Division Internal Report No. 33, "Automatic Temperature Control System for Telescope Pillboxes", by George H. Behrens, Jr. Heating is accomplished by automatically reversing the DC current thru the heat pumps.

Focusing and Polarization

Position Indicator Units for both focusing and polarization are Scientific-Atlanta, Inc., Model 1U5. These are dual pointer units with display accuracy to .03°. Diameter of the readout dial is 3 5/8 inch. Thirty-six revolutions of the Vernier pointer are required for one revolution of coarse pointer.

Synchro Transmitter Units for both focusing and polarization are Scientific-Atlanta, Inc., Model PX 1F, with synchro to shaft ratios of 1:1 and 36:1. Accuracy of .02° is obtainable. Input power requirement is 60 watts at 115 V, 60 cycles.

Drive Motors are Boston Gear Company, vertical ratiomotor type VMB 5840S. These are 115 V, single phase, 60 cycle, 1/20 HP motors with output of 43.1 RPM and 30 inch LB torque.

Focusing Rate is 1 cm/min with readout range of ± 17 cm. However, limit switches are set at 5 cm up and 8 cm down from electrical focus.

Polarization Rate is 1 RPM with position readout for 360° rotation.

Frequency Multiplier

The frequency multiplier is a Micromega varactor frequency doubler with type N female input and output connectors. The output power is $\cong 4$ dB below input with harmonic and spurious rejection > 60 dB. The output power varies $\cong 10$ percent for a temperature change from 0 °C to 70 °C. The multiplier is designed for an input frequency of 1347.5 MHz and is used to develop 2695 MHz for the local oscillator drive to the mixer through a 10 dB fixed attenuator.

FRONT-END EQUIPMENT FOR 85-1 TELESCOPE

| <u>Equipment</u> | <u>Manufacturer</u> | <u>Serial or Identification</u> |
|--------------------------------|---------------------|---------------------------------|
| Parametric amplifier | AIL | Model 4044, Ser. No. 2 |
| Paramp power supply | HP | Model 716B |
| Parametric amplifier | MPC | Model S-15 |
| Paramp power supply | MPC | NRAO Tag No. 3310 |
| Mixer-preamp | RHG | Serial No. 1-518-1 |
| Main IF amplifier | HP | Model 462A |
| Circulator | Sperry | |
| Bandpass filter | NRAO | |
| Frequency multiplier | Micromega | Model FM2-2695, Ser.No. 002 |
| Noise tube | AIL | |
| Noise tube firing box | NRAO | |
| Noise tube power supply | NRAO | |
| Bias filter | NRAO | |
| Bias supply | NRAO | |
| 50 ohm terminations | Microlab | |
| Temperature mon. thermistor | YSI | No. 409 |
| Temperature control thermistor | Fenwal | GB 32P2 |
| Thermo electric coolers (2) | Ohio Semiconductor | Peltron Model TU-6F |
| Thermoelectric heat pumps (6) | Westinghouse | Type W832G02 |
| Power supply | Harrison Labs | Model 502A |

FRONT-END EQUIPMENT FOR 85-2 TELESCOPE

| | | |
|--------------------------------|--------------------|------------------------------|
| Parametric amplifier | AIL | Model 4044, Ser. No. 1 |
| Paramp power supply | HP | Model 716B |
| Parametric amplifier | MPC | Model S-15, Ser. No. 01 |
| Paramp power supply | MPC | Model KPS-540, Ser. No. 01 |
| Mixer-preamp | RHG | Ser. No. 1-518-3 |
| Main IF amplifier | HP | Model 462A |
| Circulator | Sperry | |
| Bandpass filter | NRAO | |
| Frequency multiplier | Micromega | Model FM 2-2695, Ser.No. 001 |
| Noise tube | AIL | |
| Noise tube firing box | NRAO | |
| Noise tube power supply | NRAO | |
| Bias filter | NRAO | |
| Bias supply | NRAO | |
| 50 ohm terminations | Microlab | |
| Temperature mon. thermistor | YSI | No. 409 |
| Temperature control thermistor | Fenwal | GB 32P2 |
| Thermoelectric coolers (2) | Ohio Semiconductor | Peltron Model TU-6F |
| Thermoelectirc heat pumps (6) | Westinghouse | Type W832G02 |
| Power supply | Harrison Labs | Model 502A |

EQUIPMENT SPECIFICATIONS

TRG Model No. S 871-11 Scalar Feed Specifications

| | |
|------------------------------|--------------|
| Frequency ----- | 2695 MHz |
| Δ Frequency ----- | 35 MHz |
| VSWR ----- | < 1.2 |
| Spillover ----- | < 2 percent |
| Efficiency ----- | > 50 percent |
| Waveguide flange ----- | UG 54A/U |
| H-Plane taper ----- | 16 dB ± 60 |
| E-Plane taper ----- | 15 dB ± 60 |
| Measured VSWR, 2695 MHz ---- | 1.12 |

Provisions for pressurization.
 A detailed drawing of this feed is filed in the
 master drawing cabinet under LNL.

RHG Electronics Lab Model MP2-4/T3 Mixer-Preamplifiers (Manufacturer's Specifications)

| | Serial No. <u>1-518-1</u> | Serial No. <u>1-518-2</u> | Serial No. <u>1-518-3</u> |
|----------------------------|------------------------------|------------------------------|------------------------------|
| Frequency ----- | 2695 MHz | 2695 MHz | 2695 MHz |
| LO input Z ----- | 50 ohms | 50 ohms | 50 ohms |
| Signal input Z ----- | 50 ohms | 50 ohms | 50 ohms |
| LO Rejection ----- | 17 dB | 15 dB | 14 dB |
| IF upper 3 dB point----- | 14 MHz | 14 MHz | 14 MHz |
| IF lower 3 dB point----- | 150 kHz | 135 kHz | 150 kHz |
| Gain ----- | 20 dB (nom.) | 20 dB (nom.) | 20 dB (nom.) |
| Noise figure ----- | 9 dB | 9 dB | 9 dB |
| Output Z ----- | 50 ohms | 50 ohms | 50 ohms |
| Power drain 30 volts ---- | 30 mA | 30 mA | 30 mA |
| LO Connector ----- | Type N | Type N | Type N |
| Signal Connector ----- | Type N | Type N | Type N |
| IF Output connector ----- | BNC | BNC | BNC |
| Xtals (matched pair) ----- | 1N21E- 1N21ER | 1N21E- 1N21ER | 1N21E- 1N21ER |

Hewlett-Packard Model 462A Main IF Amplifier (Manufacturer's Specifications)

| | | |
|------------------|-------|----------------------|
| Frequency range | ----- | 1 kHz - 150 MHz |
| Gain | ----- | 20 dB or 40 dB |
| Input Z | ----- | 50 ohm nominal |
| Output Z | ----- | 50 ohm nominal |
| Output voltage | ----- | 1 V p-p into 50 ohms |
| Input connector | ----- | BNC |
| Output connector | ----- | BNC |
| Power supply | ----- | 115 V AC, 60 Hz |
| Fuse | ----- | 1/4 amp Slo Blo |

LABORATORY MEASUREMENTS

Front-End Equipment for 85-1 Telescope

System Measurements

| | |
|-----------|------------------------|
| Gain | Approximately 88 dB |
| BW (1 dB) | 2715-2677 MHz = 38 MHz |

AIL Parametric Amplifier Model 4044, Ser. No. 2

| | |
|----------------|------------------------|
| Gain | 15 dB |
| BW (1 dB) | 2714-2674 MHz = 40 MHz |
| T _e | ≅ 75 °K |

MPC Parametric Amplifier Model S-15

| | |
|----------------|-------------------------|
| Gain | 15 dB |
| BW (1 dB) | 2753-2648 MHz = 105 MHz |
| Response flat | 2740-2666 MHz = 74 MHz |
| T _e | < 180 °K |

RHG Mixer Preamplifier Serial No. 1-518-1

Measurement taken from output of MPC paramp to input of main IF amplifier and includes loss of circulator and BP filter.

| | |
|----------------|------------------------|
| Gain | 18.5 dB |
| BW (1 dB) | 2715-2677 MHz = 38 MHz |
| T _e | ≅ 1700 °K |

H-P Main IF Amplifier Model 462A

Measurement taken from output of MPC paramp to output of IF amp
Gain of mixer-preamp taken into account.

| | |
|-----------|------------------------|
| Gain | 40 dB |
| BW (1 dB) | 2715-2677 MHz = 28 MHz |

Front-End Equipment for 85-2 Telescope

System Measurements

| | |
|-----------|------------------------|
| Gain | Approximately 90 dB |
| BW (1 dB) | 2715-2678 MHz = 37 MHz |

AIL Parametric Amplifier Model 4044, Ser. No. 1

| | |
|-----------|------------------------|
| Gain | 15 dB |
| BW (1 dB) | 2715-2678 MHz = 37 MHz |
| T_e | $\cong 75$ °K |

MPC Parametric Amplifier Model S-15

| | |
|---------------|-------------------------|
| Gain | 15 dB |
| BW (1 dB) | 2745-2635 MHz = 110 MHz |
| Response flat | 2725-2665 MHz = 60 MHz |
| T_e | < 180 °K |

RHG Mixer-Preamplifier, Ser. No. 1-518-3

Measurement taken from output of MPC paramp to input of main IF
amp and includes loss of circulator and BP filter.

| | |
|-----------|------------------------|
| Gain | 20 dB |
| BW (1 dB) | 2715-2677 MHz = 38 MHz |
| T_e | $\cong 1700$ °K |

H-P Main IF Amplifier Model 462A

Measurement taken from output of MPC paramp to output of IF amp
Gain of mixer-preamp taken into account.

| | |
|-----------|------------------------|
| Gain | 40 dB |
| BW (1 dB) | 2715-2677 MHz = 38 MHz |

AIL Paramp Bias Calibration for 85-1 Telescope

| <u>Frequency (MHz)</u> | <u>Helipot Reading</u> |
|------------------------|------------------------|
| 2675 | 8.16 |
| 2680 | 7.88 |
| 2685 | 7.68 |
| 2690 | 7.53 |
| 2695 | 7.33 |
| 2700 | 7.14 |
| 2705 | 6.96 |
| 2710 | 6.75 |
| 2715 | 6.57 |

AIL Paramp Bias Calibration for 85-2 Telescope

| <u>Frequency (MHz)</u> | <u>Helipot Reading</u> |
|------------------------|------------------------|
| 2675 | 0.85 |
| 2680 | 0.78 |
| 2685 | 0.72 |
| 2690 | 0.68 |
| 2695 | 0.64 |
| 2700 | 0.59 |
| 2705 | 0.52 |
| 2710 | 0.46 |
| 2715 | 0.39 |
| 2720 | 0.33 |
| 2725 | 0.27 |

TELESCOPE MEASUREMENTS

Measurements Taken After Installation on 85-1 Telescope

| | |
|---------------------------|---|
| System BW (1 dB) | 37 MHz |
| System Noise Temperature | 130 °K |
| System Calibration Signal | 27.75 °K |
| AIL Paramp Gain | 14 dB (insertion loss approximately 2 dB), gain = 16 dB |
| MPC Paramp Gain | 15 dB |
| Data -- AIL Paramp | |
| Bias | 5.95 Helipot Reading |
| Ref V | 3.50 |
| Beam V | 9.41 |
| Beam I | 34 mA Meter |

Measurements Taken After Installation on 85-1 Telescope (Continued) --

| | | |
|--------------------|----------------------|--------------|
| Data -- MPC Paramp | | |
| Ref V | 6.50 Helipot Reading | 320 V Meters |
| Beam V | 7.09 Helipot Reading | 470 V Meters |
| Beam I | 48 mA Meter | |
| Timer | 3801.5 | |

Measurements Taken After Installation on 85-2 Telescope

| | | |
|--------------------------|---|-------------|
| System BW (1 dB) | 38 MHz | |
| System Noise Temperature | 125 °K | |
| System Noise Calibration | 23.75 °K | |
| AIL Paramp Gain | 13 dB (insertion loss approximately 2 dB), gain = 15 dB | |
| MPC Paramp Gain | 15 dB | |
| Data -- AIL Paramp | | |
| Bias | 0.50 Helipot Reading | |
| Ref V | 3.81 | |
| Beam V | 9.54 | |
| Beam I | 28 mA Meter | |
| -- MPC Paramp | | |
| Ref V | 4.45 Helipot Reading | 310 V Meter |
| Beam V | 5.62 Helipot Reading | 470 V Meter |
| Beam I | < 48 mA Meter | |
| Timer | 4171.4 | |

MAINTENANCE

The gain-bandpass characteristics of the front end system can be observed in the control room. See block diagram for equipment required and method used. The following steps outline the procedure used to observe the overall system response:

1. Make connections shown for calibration in Figure 14. Adjust sweep generator for center frequency of 2695 MHz with sweep width of ± 40 MHz. Adjust the scope sensitivity, generator output control and variable attenuator as required to observe linearity of the sweep output and proper sweep range.

2. Make connections to the front end equipment as shown in Figure 14. Adjust the generator output, variable attenuator and scope sensitivity as required. To avoid saturation of the front end equipment, the sweep output should be as low as practical with scope sensitivity as high as practical. Generally, the peak-to-peak noise of the system will determine the minimum sweep level and maximum scope sensitivity to be used. Attenuation setting of ≈ 50 dB and scope sensitivity of ≈ 50 mv/cm will be required with generator output control set to five.
3. After step 2 adjustments give a suitable display, a 1 dB down calibration point should be established on the scope. This can be done by observing the amplitude of the scope trace, then adding 1 dB attenuation in the sweep line. If a dual beam scope is used, the unused beam can be moved to mark the calibration line.
4. The 1 dB points should be checked with an external frequency marker. Do not rely on the generator built-in markers. The response curve should be flat within 1 dB from 2680 MHz to 2710 MHz.

The following steps outline the procedure used to determine the individual paramp gains and bandpass. The MPC paramp (second stage amplifier) should be measured first as follows:

1. With test set-up and scope display described in step 4 above, turn off the high voltage to the AIL paramp and the MPC paramp and adjust the variable attenuator for a convenient display on the scope. Note the attenuator setting and the display amplitude.
2. Turn on the MPC high voltage and adjust the variable attenuator for the same display level noted in step 1.

3. The difference between the new attenuator setting and the setting noted in step 1 is the gain of the MPC paramp and should be 15 dB.
4. The reflector and beam voltages should be adjusted for flat response and 15 dB gain.

The AIL paramp gain can be measured using the same procedure as for the MPC paramp; however, an attenuator difference of 13 dB is equivalent to a paramp gain of 15 dB. (Insertion loss of the AIL paramp is $\cong 2$ dB when off.) The AIL paramp can be aligned using the reflector, beam and bias adjustments.

ACCESS TO THE FRONT-END EQUIPMENT

The elevator should be positioned for access to the pillbox door at the 85-1 telescope or the same relative position for the 85-2 telescope. The AIL paramp is mounted in the center of the tee box body and the MPC is mounted in one of the tee box arms. The polarization may have to be rotated for best access to both paramps. The MPC adjustments can be reached thru the end of the tee box arm by removing the end plate of the tee box arm. See the block diagram showing relative position of equipment.

NOISE TEMPERATURE MEASUREMENTS

Noise temperature measurements of components were made prior to installation in the tee box, but accurate system measurements could not be made after the equipment was installed due to the mechanical configuration. Attempts to measure the system noise temperature in the lab using the absorbent material in front of the feed horn were not too successful but did serve to indicate that the equipment was at least close to specifications. Noise temperature measurements made on the telescope show that the complete system temperature (including antenna) for 85-1 is 130 °K and 125 °K for 85-2.

The system noise temperature is determined by comparing the recorder deflector for the calibration noise signal with the deflection for 1 dB increase of IF level.

$$T_s = \left(\frac{d_{1 \text{ dB}}}{d_{\text{cal}}} \right) \frac{T_{\text{cal}}}{.26}$$

where

- T_s = system noise temperature in degrees Kelvin
- $d_{1 \text{ dB}}$ = deflection for 1 dB gain increase
- d_{cal} = deflection for noise calibration signal
- T_{cal} = temperature of calibration signal expressed in degrees Kelvin

$$\text{For 85-1 } T_{\text{cal}} = 27.75 \text{ }^\circ\text{K}$$

$$\text{For 85-2 } T_{\text{cal}} = 23.75 \text{ }^\circ\text{K}$$

DISCUSSION

This report describes the front end equipment used in the present interferometer system, installed September 1965. This is the first attempt to use two ambient temperature parametric amplifiers in each front end. The previous system used only the MPC paramp, which is now used as the second RF amplifying stage. The MPC paramp has been adjusted for wider bandwidth ($\cong 100$ MHz) with lower gain (15 dB) in an attempt to achieve better gain stability with low second stage noise contribution. The first stage paramp (AIL) is an extremely low noise amplifier with noise temperature of $\cong 75$ °K, and the second stage paramp (MPC) is less than 180 °K.

The system has been operational for more than 1000 hours at this time. The klystron (283G) for the AIL paramp is rated at 5000 hours and the beam current has remained constant since installation, indicating that the pump power has not changed. The pump power for the MPC paramp at 85-1 has been decreasing. This klystron (246A) has a rating of 1000 hours and the beam current has dropped from 48 mA to 41 mA since installation. Automatic control of pump power and pump frequency would be desirable, but remote manual control may be adequate to correct for long term drift due to normal

klystron aging. The klystrons for the present system were adjusted with beam voltages lower than normal to allow range of electronic adjustment at the control room. This method has been satisfactory. After 1000 hours of continuous operation only one paramp (MPC at 85-1) has required mechanical adjustment.

Maintenance information indicates that two parametric amplifiers can be successfully operated in tandem when the pillbox temperature is held constant. System noise temperature measurements taken three times daily show that the system noise temperature has not varied more than a few degrees since installation. Maintenance logs are being kept with records of adjustments performed and photographs of bandpass characteristics before and after adjustments.

FIGURE 1 -- CONTROL ROOM CABLING

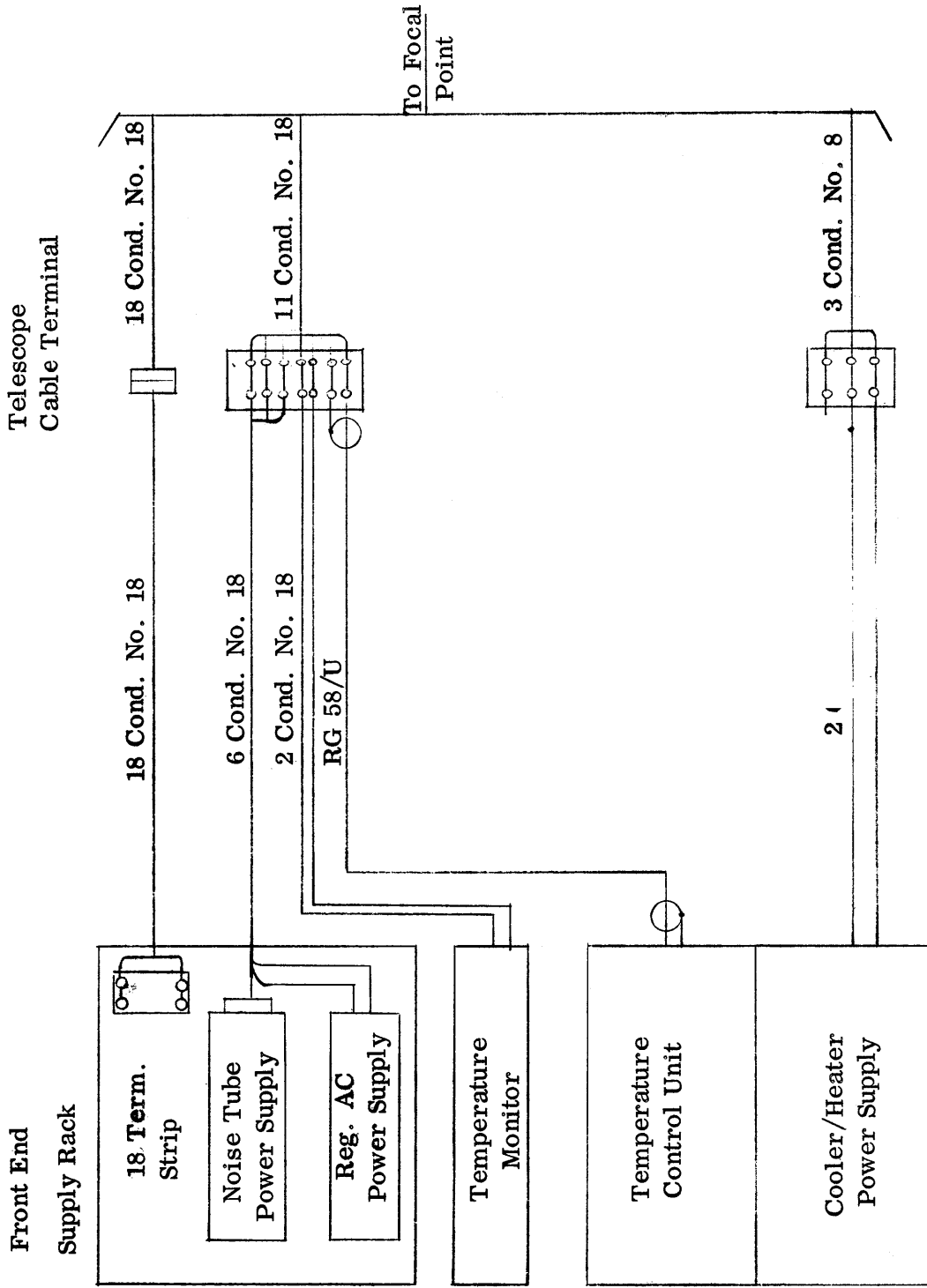
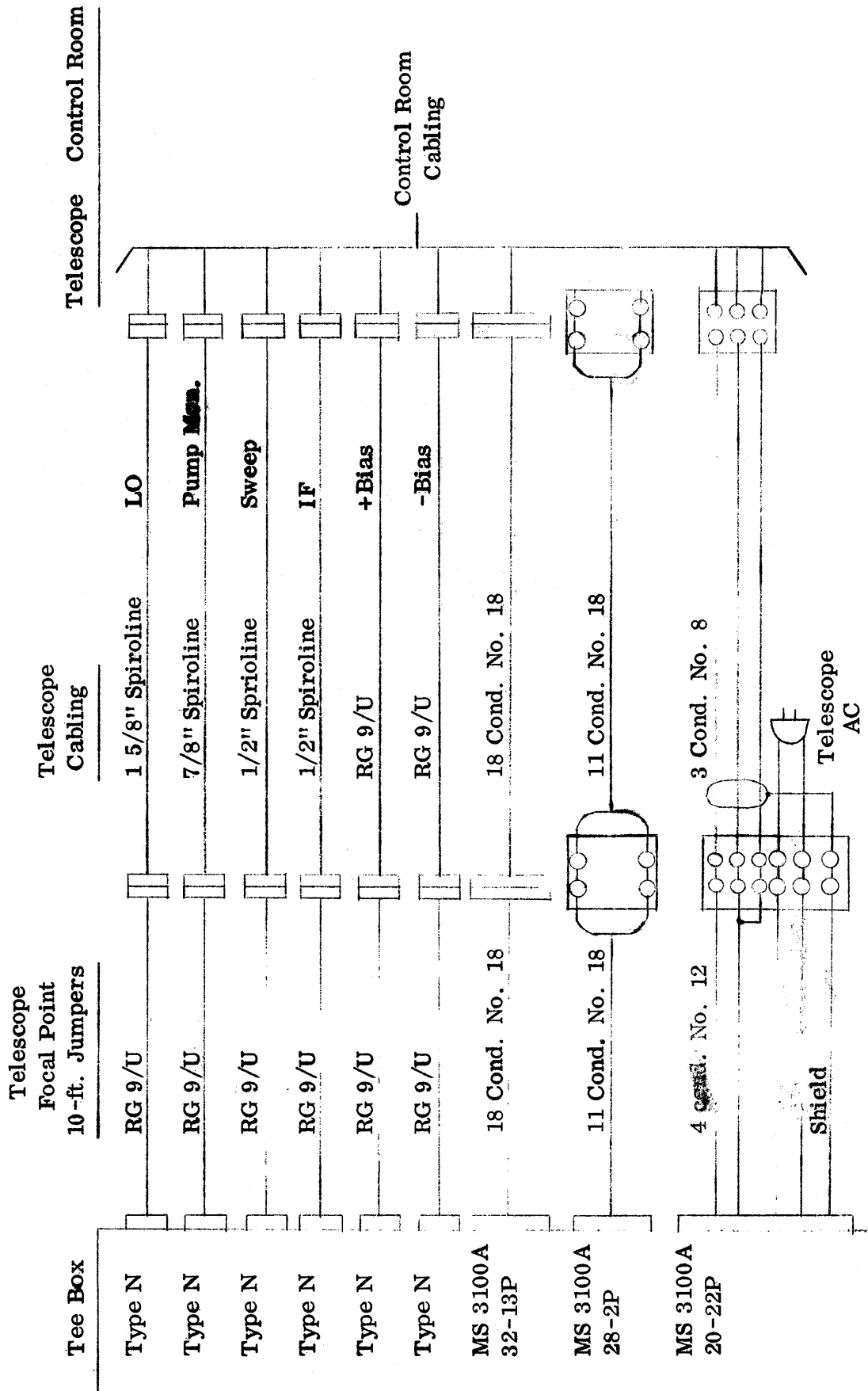
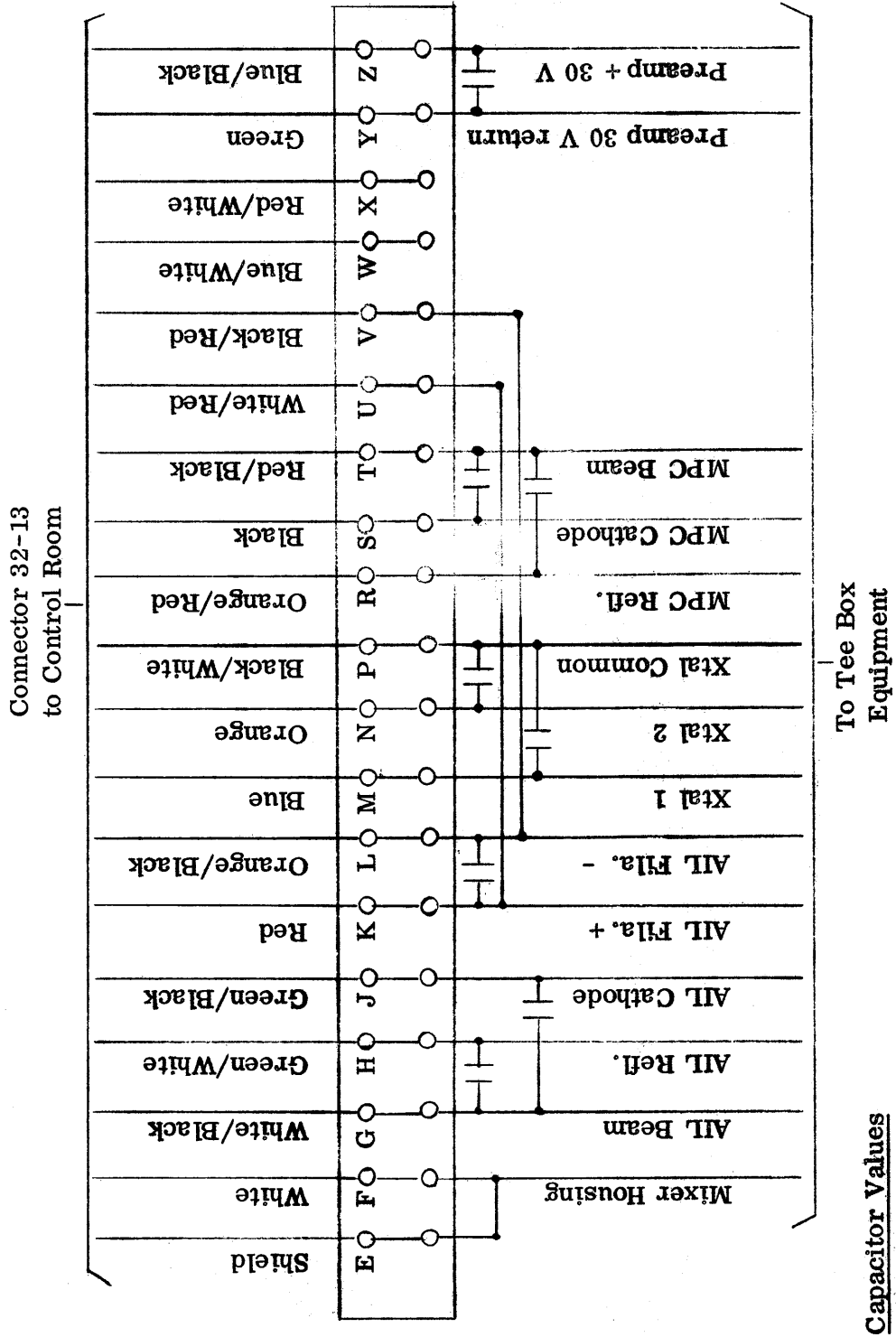

FIGURE 2 - 85-1 AND 85-2 TELESCOPE CABLING



All multi-conductors have outer shield.

FIGURE 3 - 18 CONDUCTOR CABLE TEE BOX TERMINAL WIRING



Capacitor Values
 G-H, G-J, R-T, S-T - .1 mfd 1000 V
 K-L, M-P, N-P, Y-Z - .1 mfd 200 V

FIGURE 4 - 11 CONDUCTOR CABLE TEE BOX TERMINAL WIRING

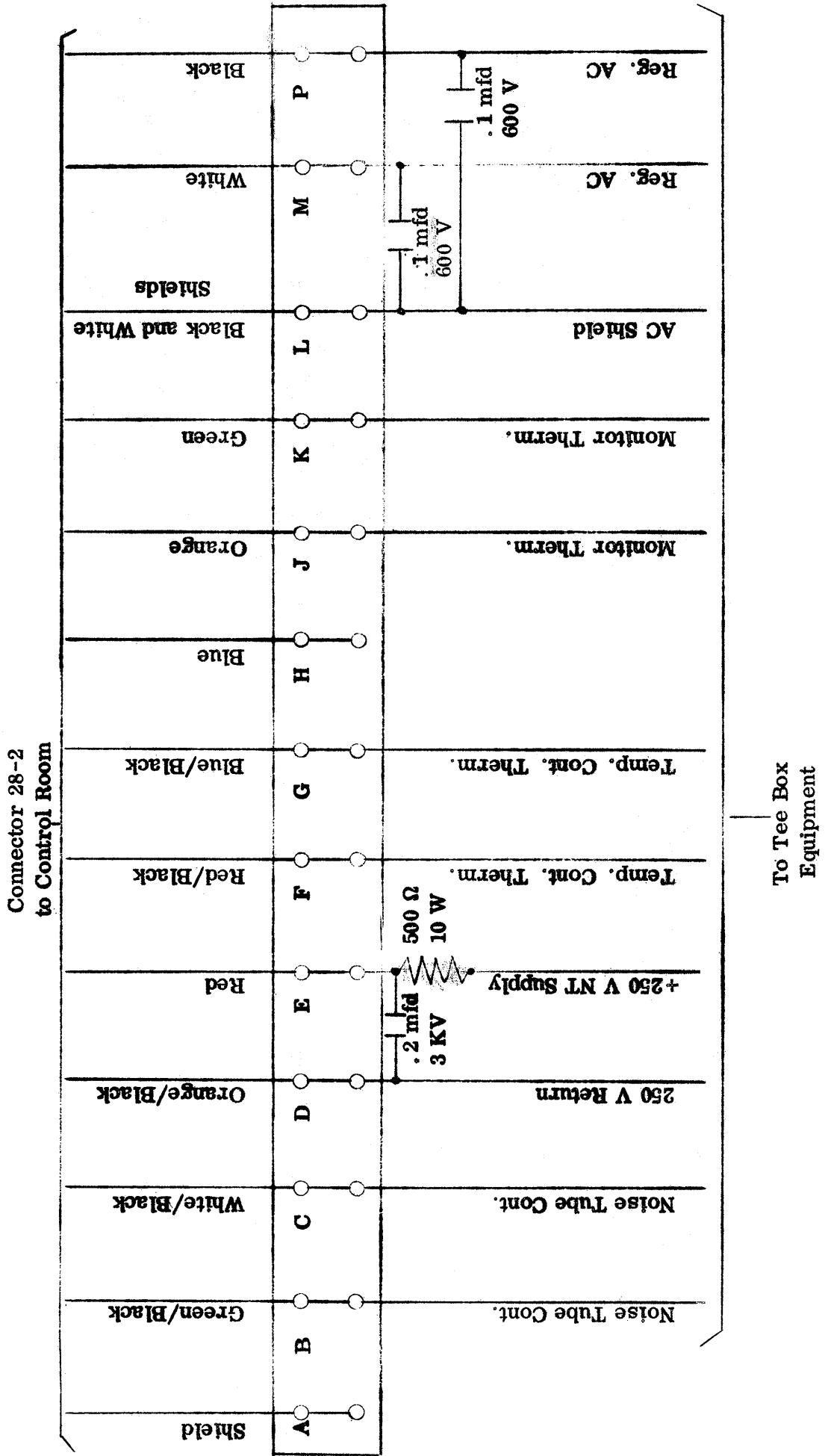

FIGURE 5 — WIRING DIAGRAM FOR HEATERS/COOLERS

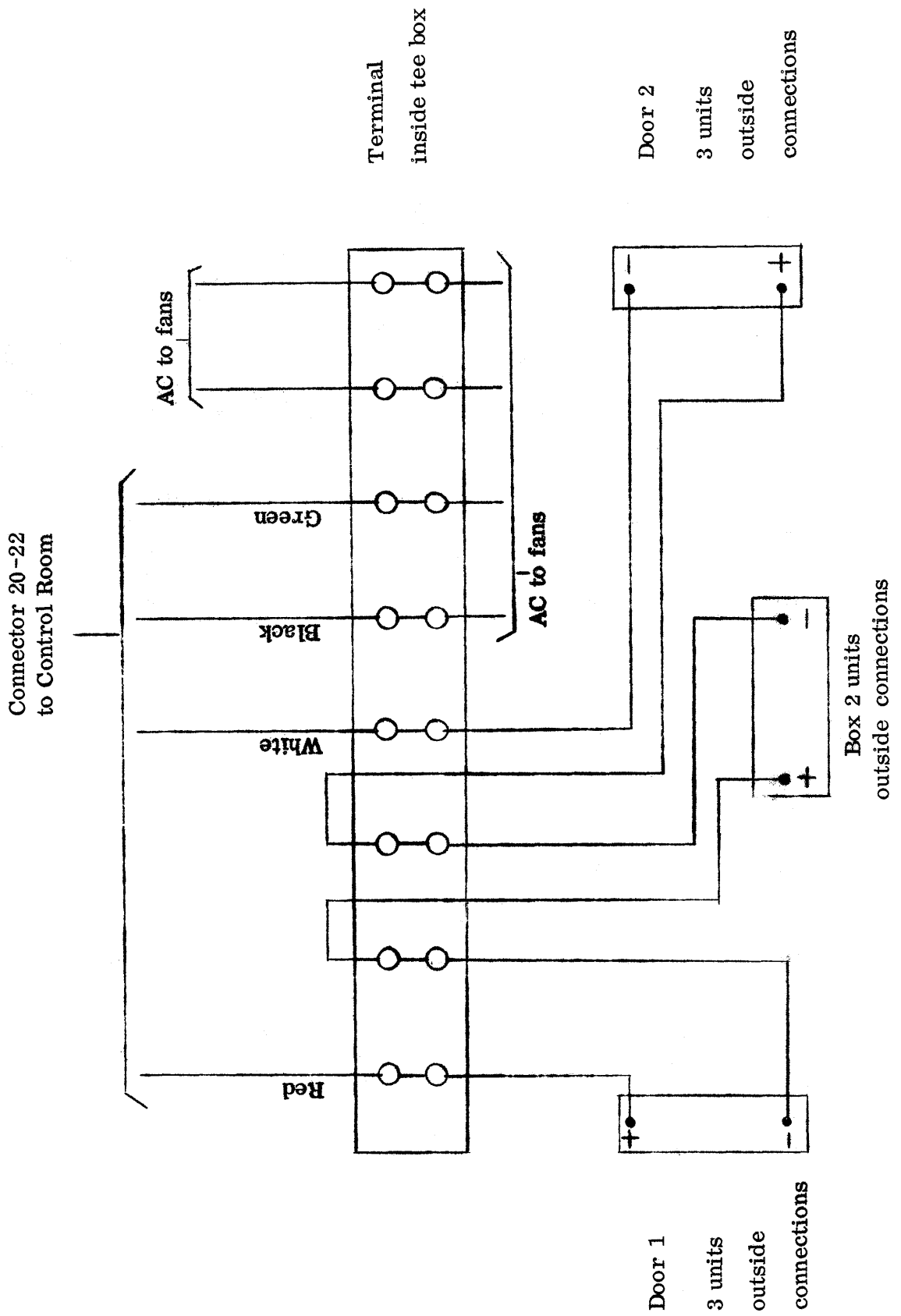

FIGURE 6 — TOP VIEW TEE BOX SHOWING CABLE CONNECTOR LAYOUT

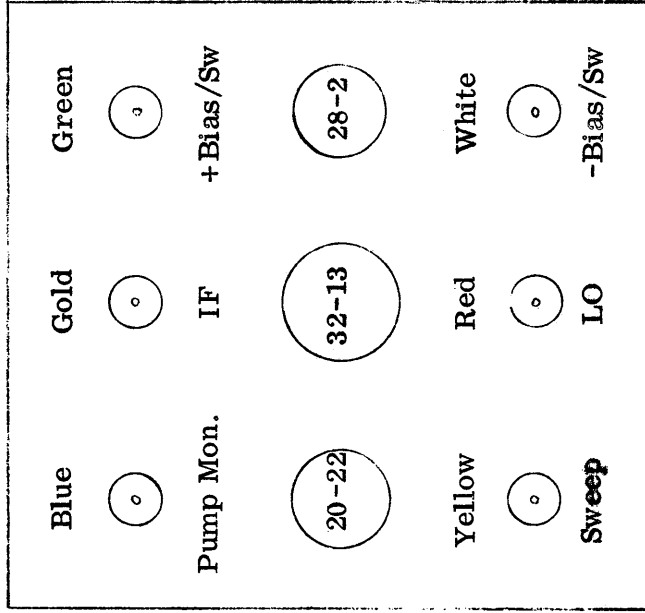

FIGURE 7 -- SKETCH SHOWING COMPONENT LAYOUT IN ARMS OF TEE BOX

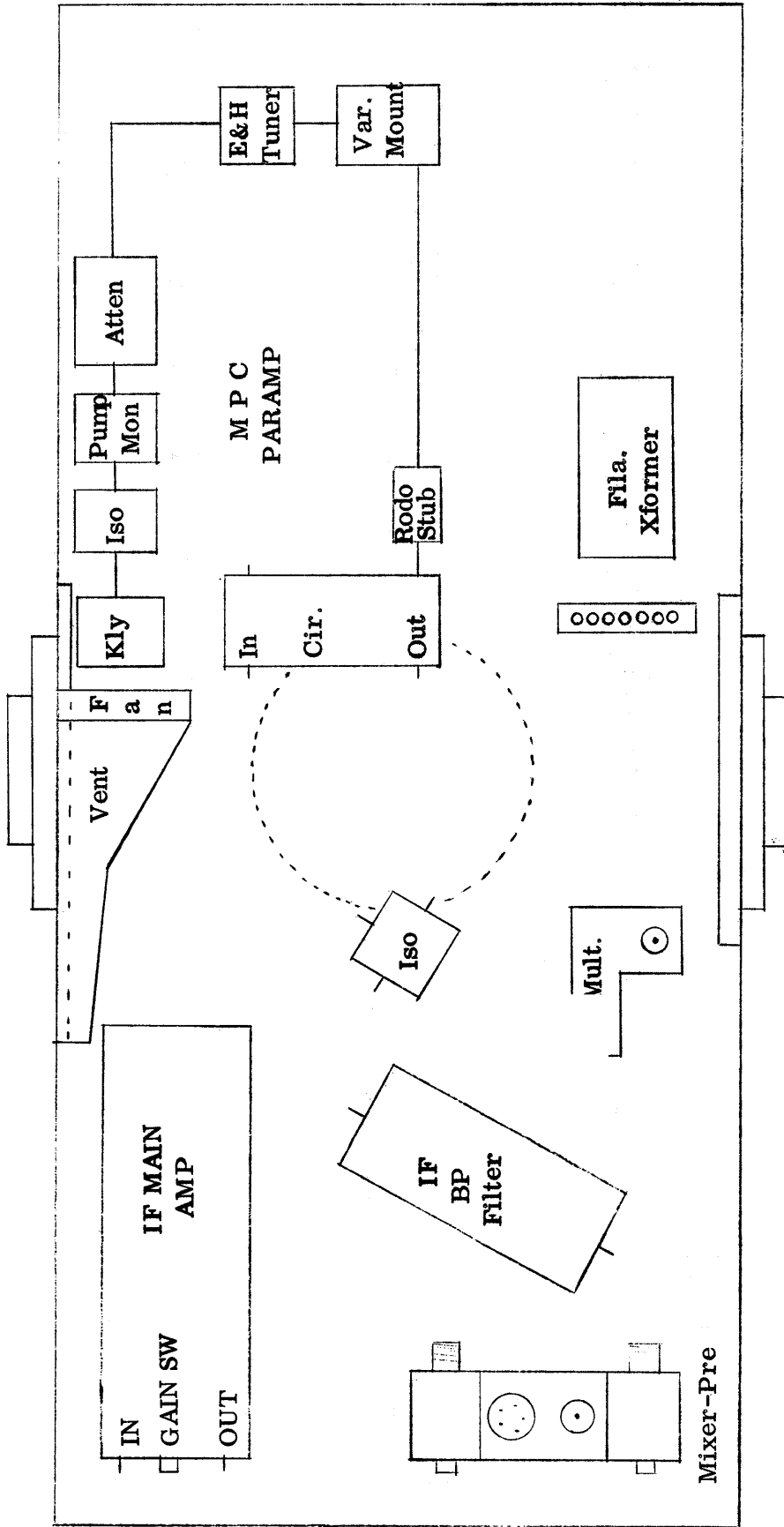

FIGURE 8 - BLOCK DIAGRAM OF AIL PARAMETRIC AMPLIFIER AFTER MODIFICATION

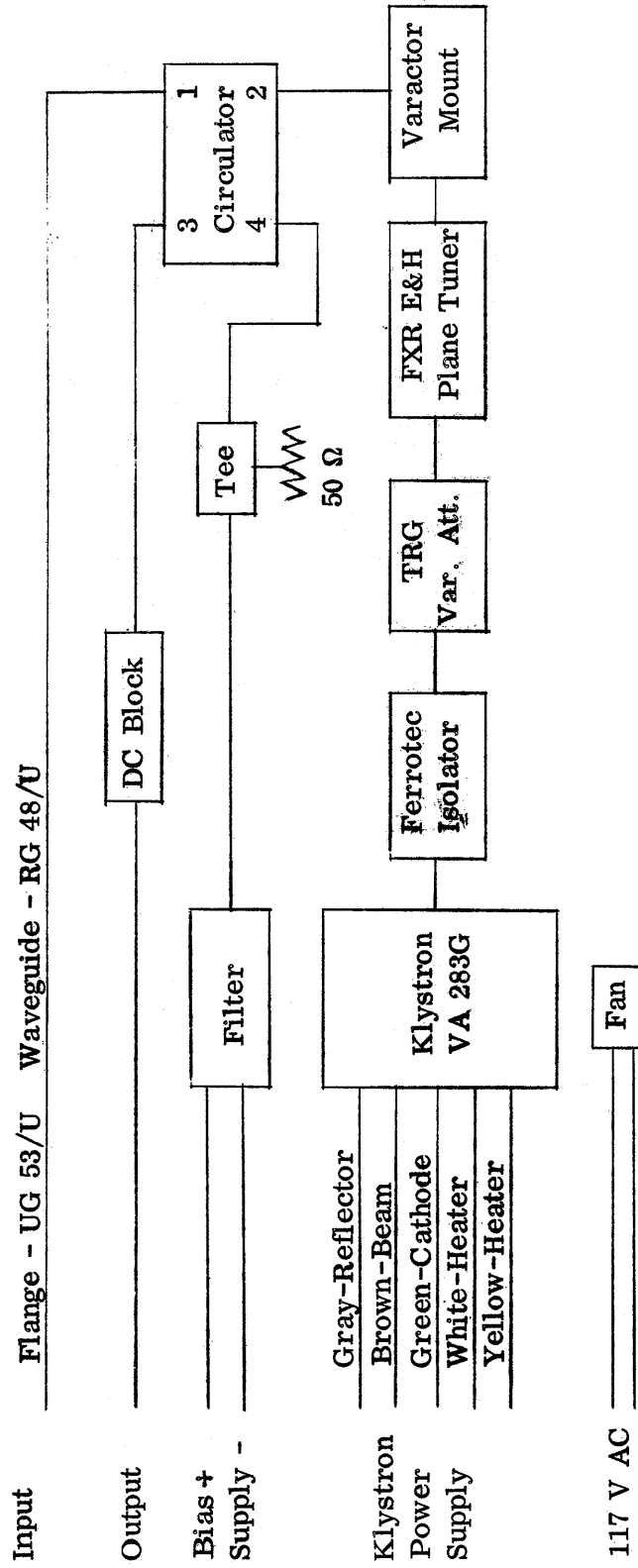
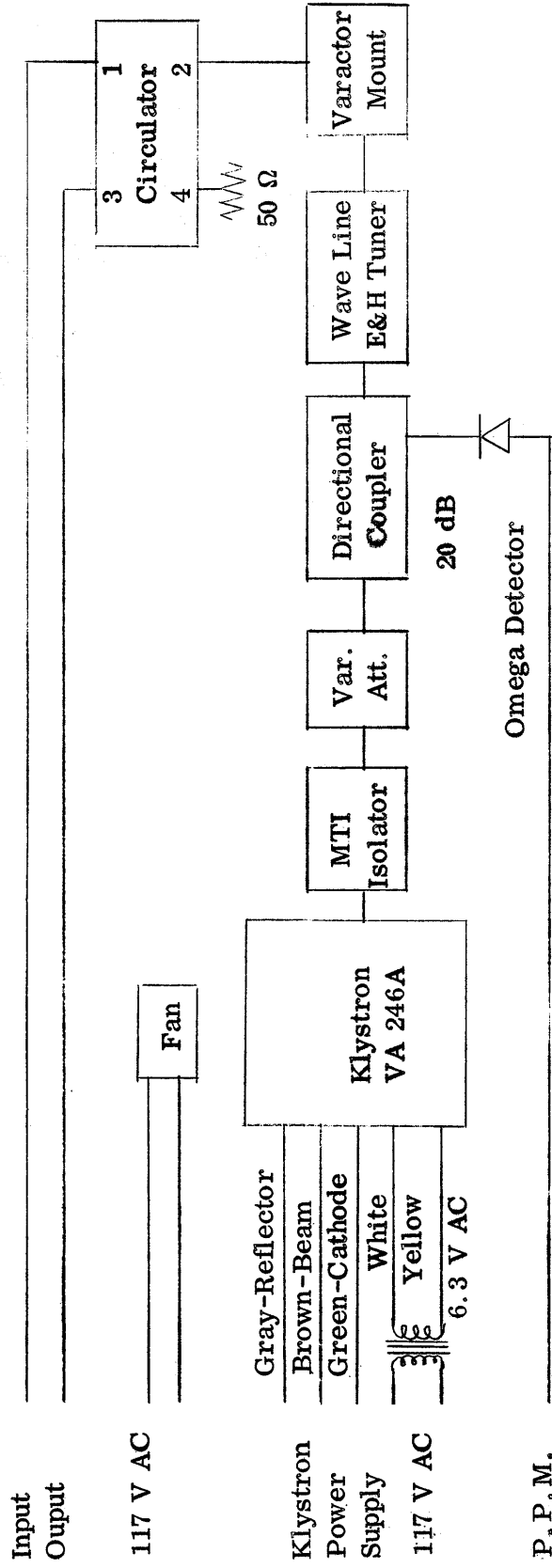

FIGURE 9 — BLOCK DIAGRAM OF MPC PARAMETRIC AMPLIFIER AFTER MODIFICATION



P. P. M.

FIGURE 10 - INTERFEROMETER FRONT-END FOR 85-1 TELESCOPE

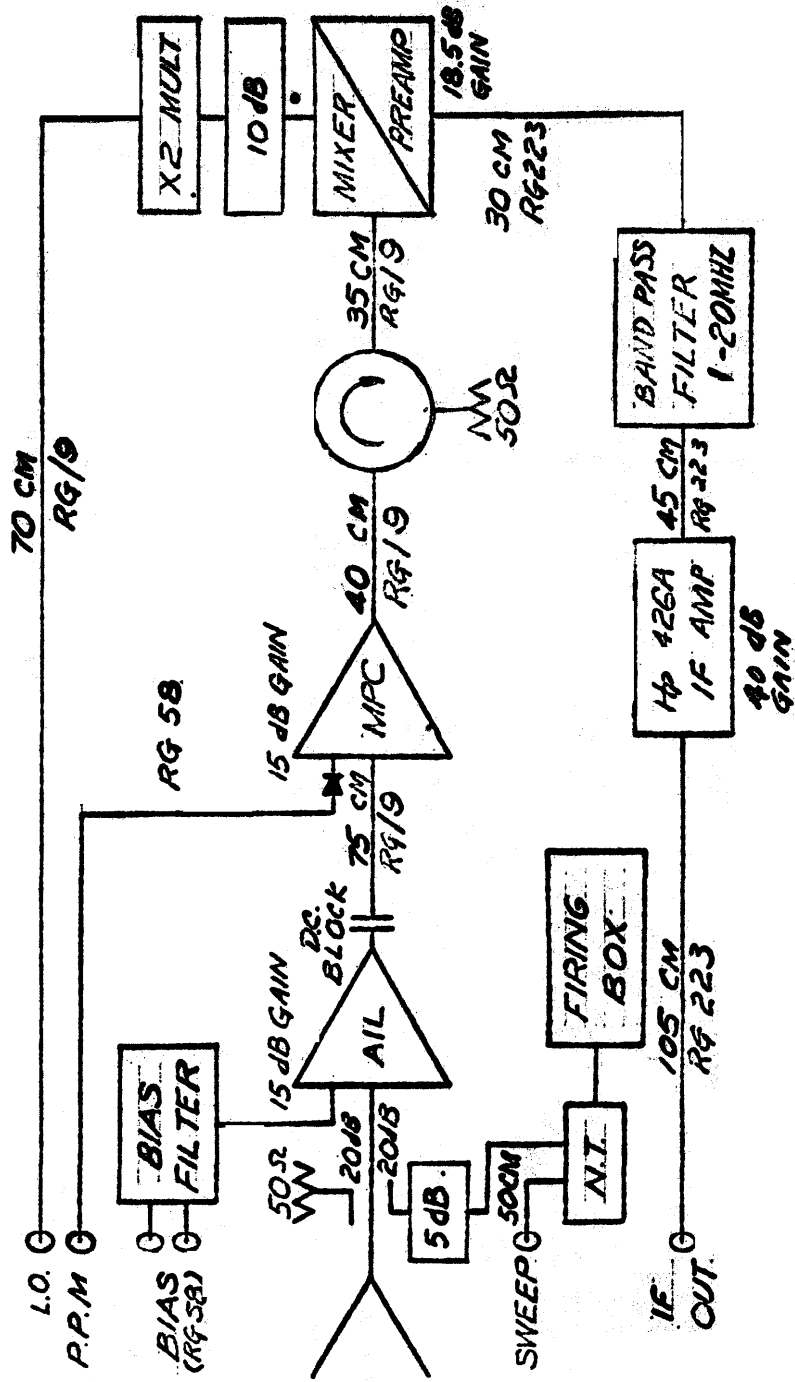

FIGURE 11 -- INTERFEROMETER FRONT-END FOR 85-2 TELESCOPE

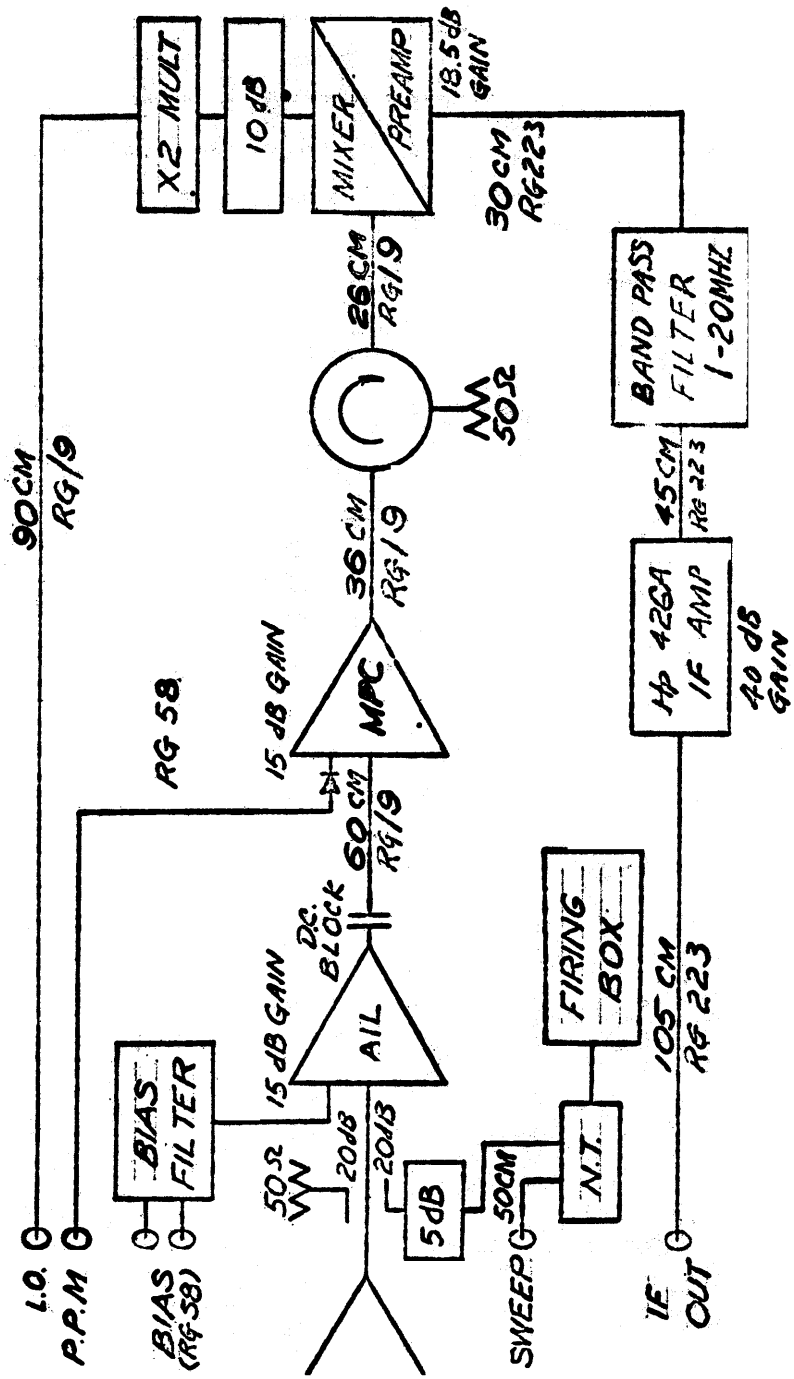
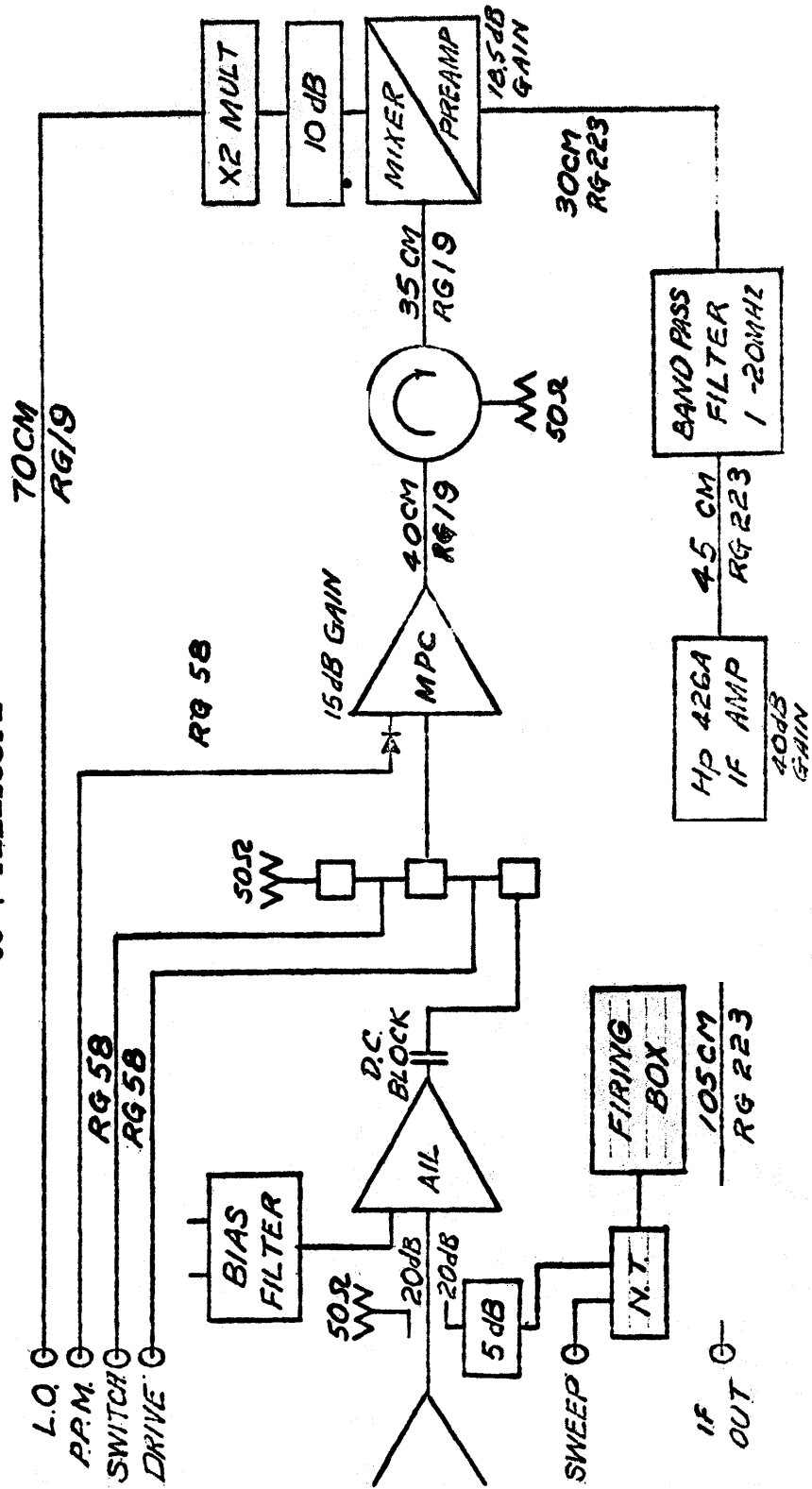

FIGURE 12 -- INTERFEROMETER FRONT-END FOR DICKE RECEIVER
85-1 TELESCOPE



**FIGURE 13 --INTERFEROMETER FRONT-END FOR DICKE RECEIVER
85-2 TELESCOPE**

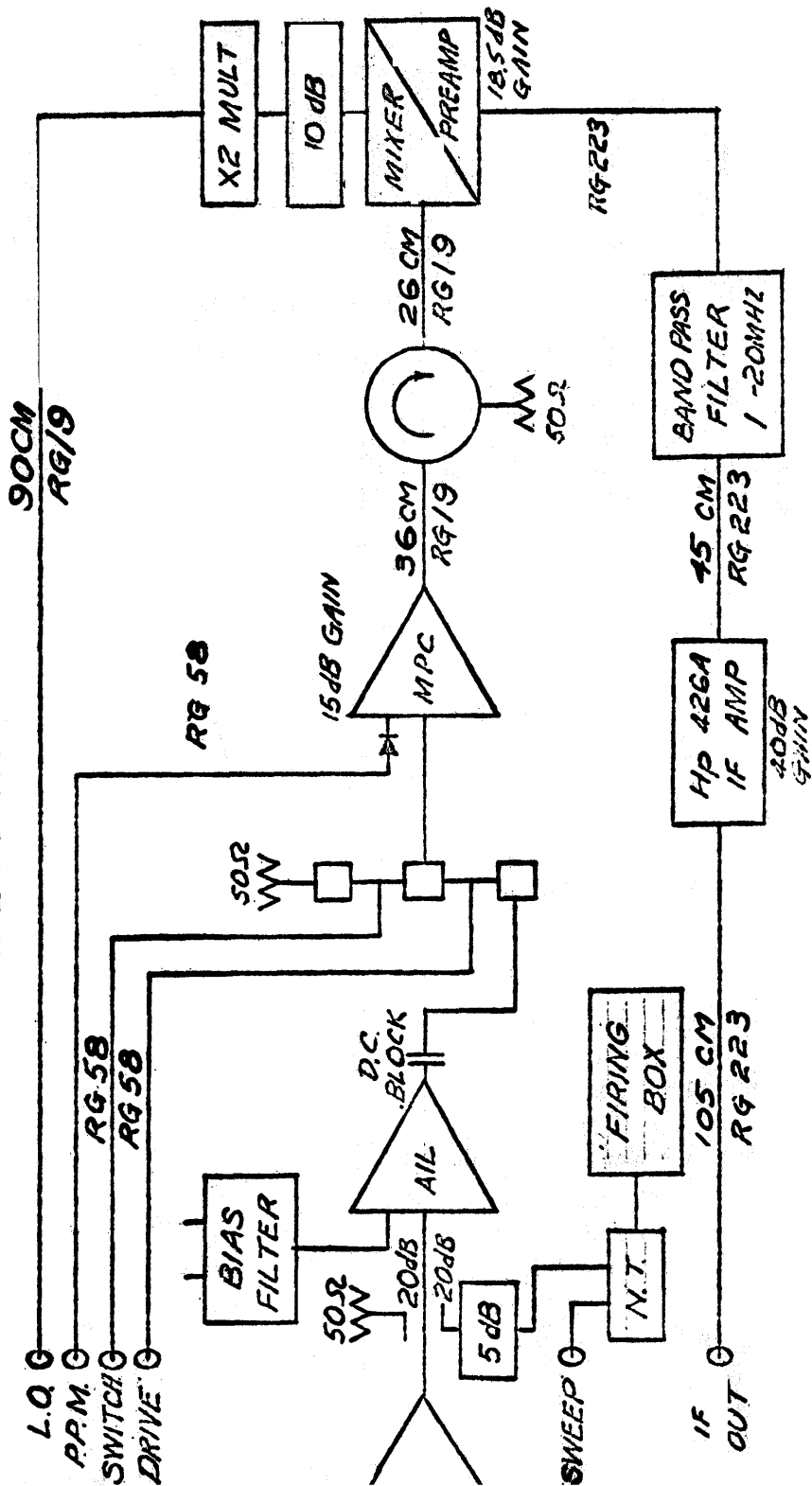

FIGURE 14 — TEST EQUIPMENT ARRANGEMENT USED TO OBSERVE
SYSTEM GAIN-BANDPASS AT TELESCOPE CONTROL ROOM

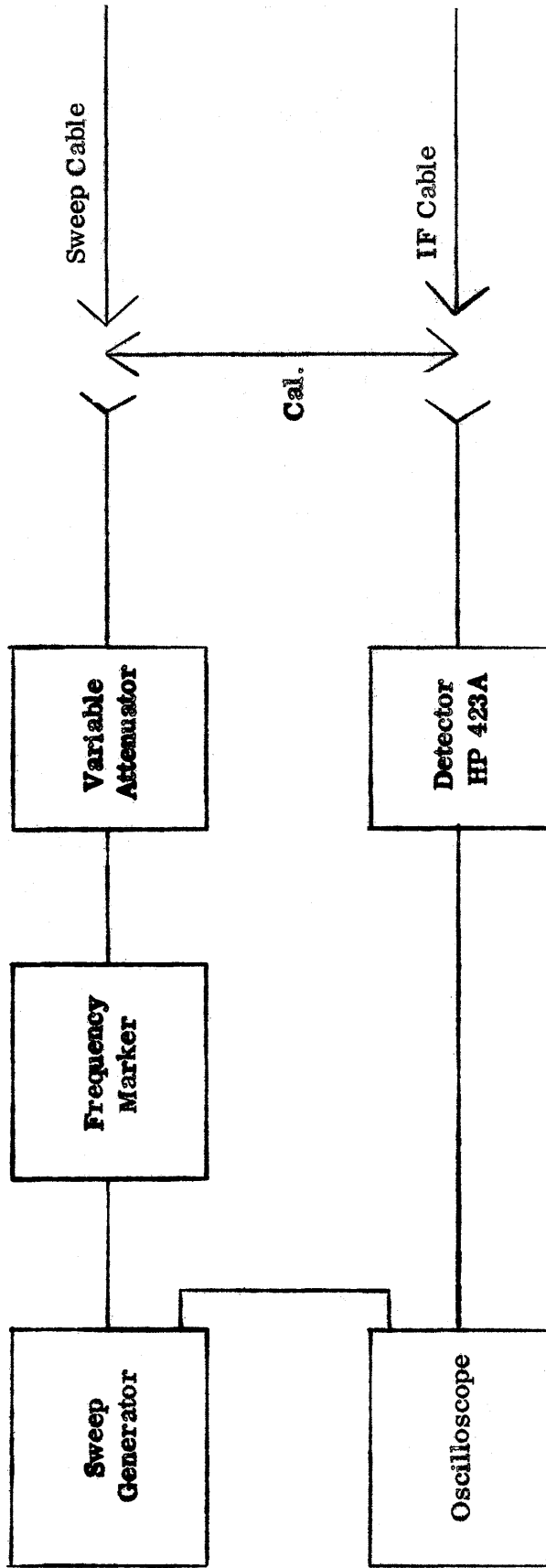

FIGURE 15 — NOISE TUBE POWER SUPPLY

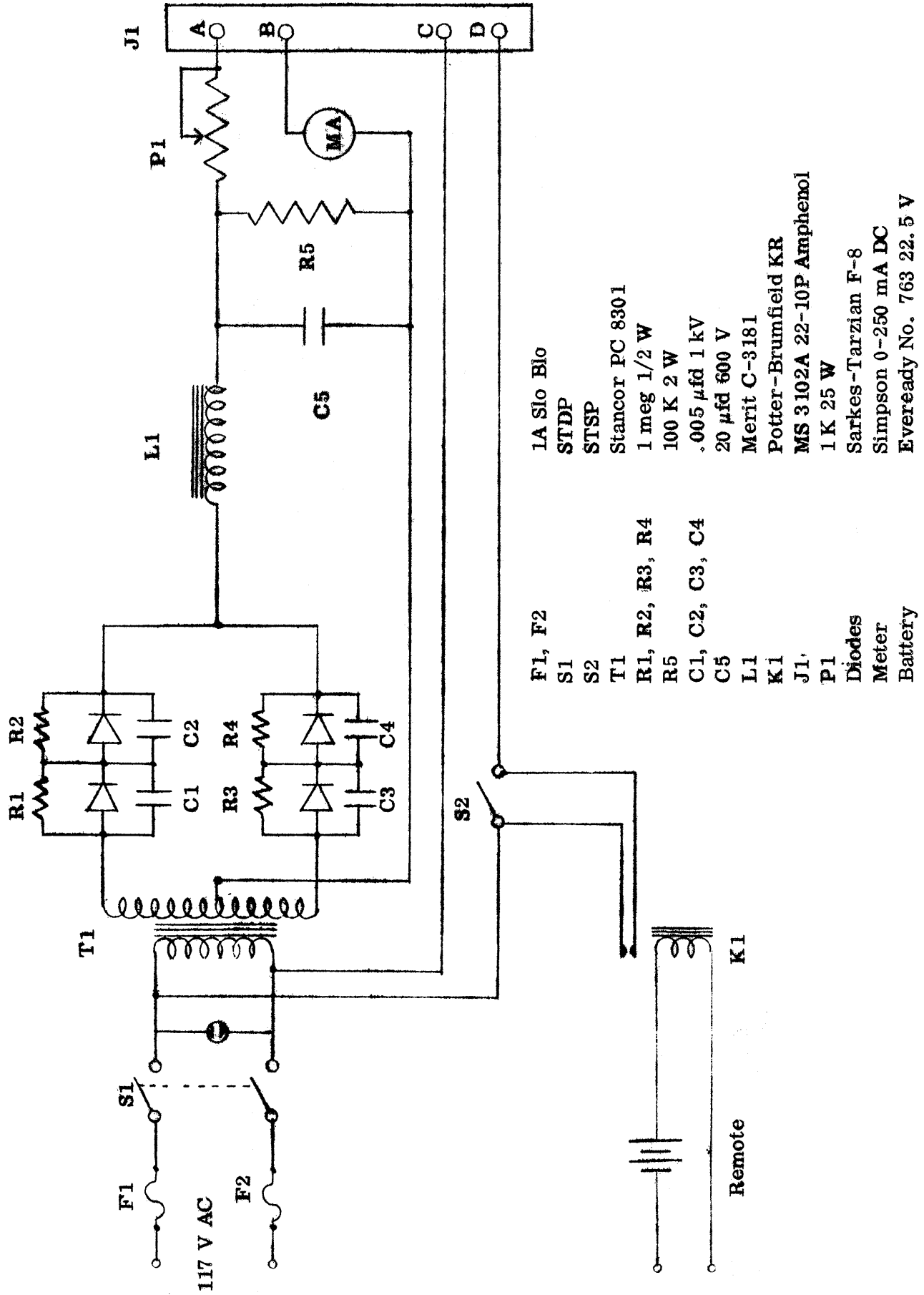
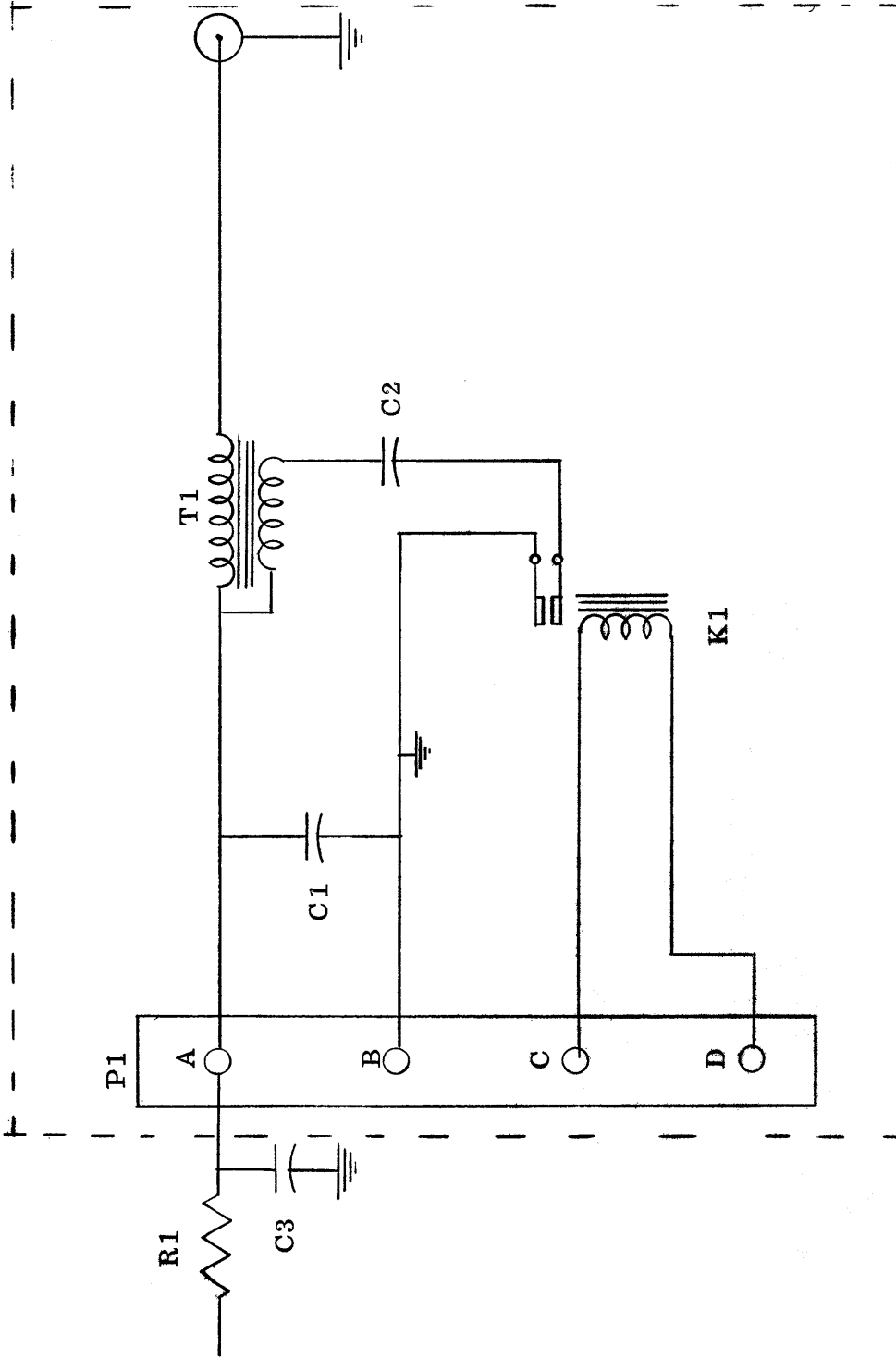

FIGURE 16 -- NOISE TUBE FIRING BOX



- | | | | |
|----|--------------------------|-----------|-----------------|
| K1 | Potter-Brumfield PR 5 AY | T1 | Stancor 8 190 |
| P1 | MS 3102A 22-10P Amphenol | Connector | UG 931/U |
| C1 | 06 μ f 3 kV | R1 | 500 ohm 10 W |
| C2 | 16 μ f 600 V | C3 | .2 μ f 3 kV |

Requires external R1 and C3

FIGURE 17 — IF BANDPASS FILTER 1 MHz - 20 MHz

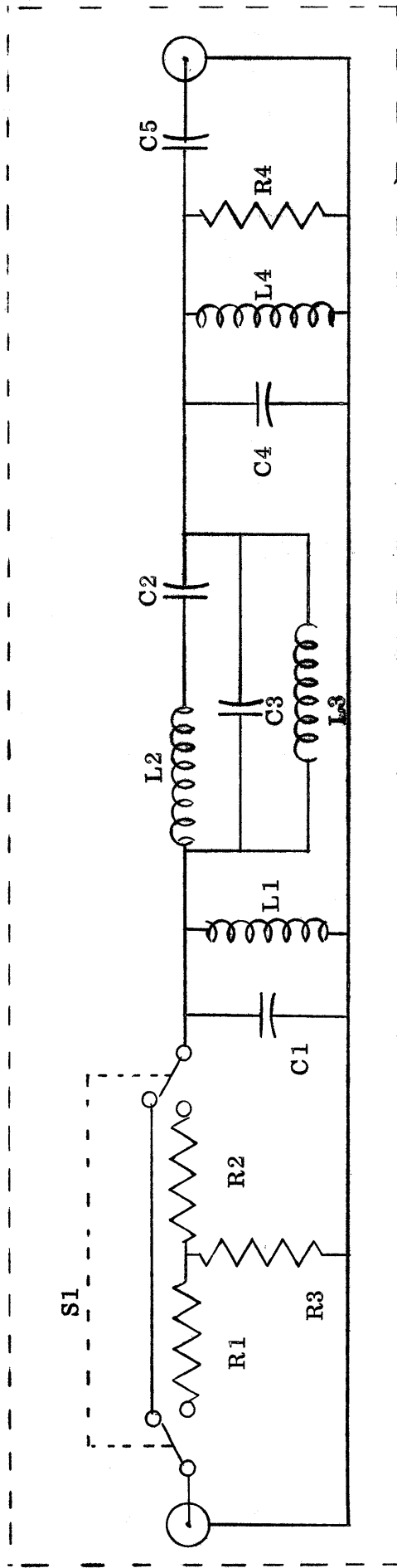

Component Values

- R1 = 27Ω
- R2 = 27Ω
- R3 = 33Ω
- R4 = 50Ω
- S1 = DPST Toggle Switch
- Connectors = BNC
- L1 = 6 μh
- L2 = .31 μh
- L3 = 14 μh
- L4 = 6 μh
- C1 = 212 pf
- C2 = 4050 pf
- C3 = 90 pf
- C4 = 212 pf

FIGURE 18 — AIL PARAMP BIAS SUPPLY

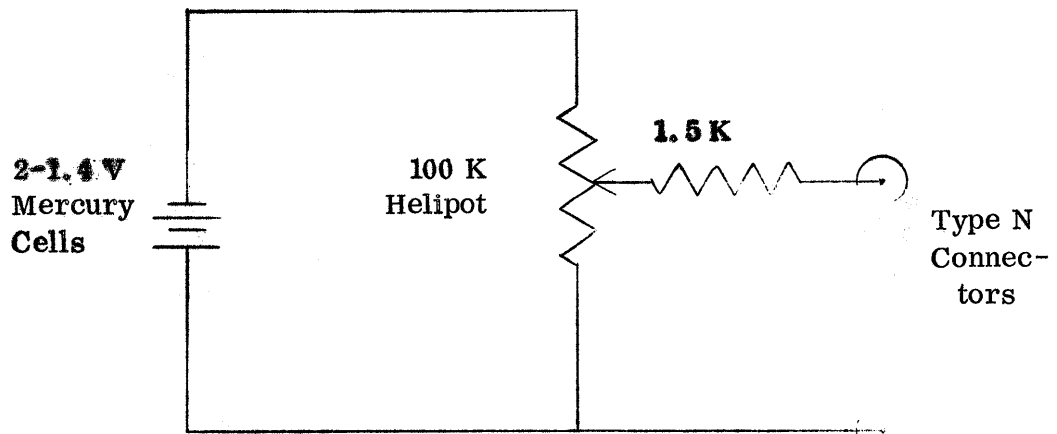

Bias supply shielded and isolated from ground.

FIGURE 19 — AIL PARAMP BIAS FILTER

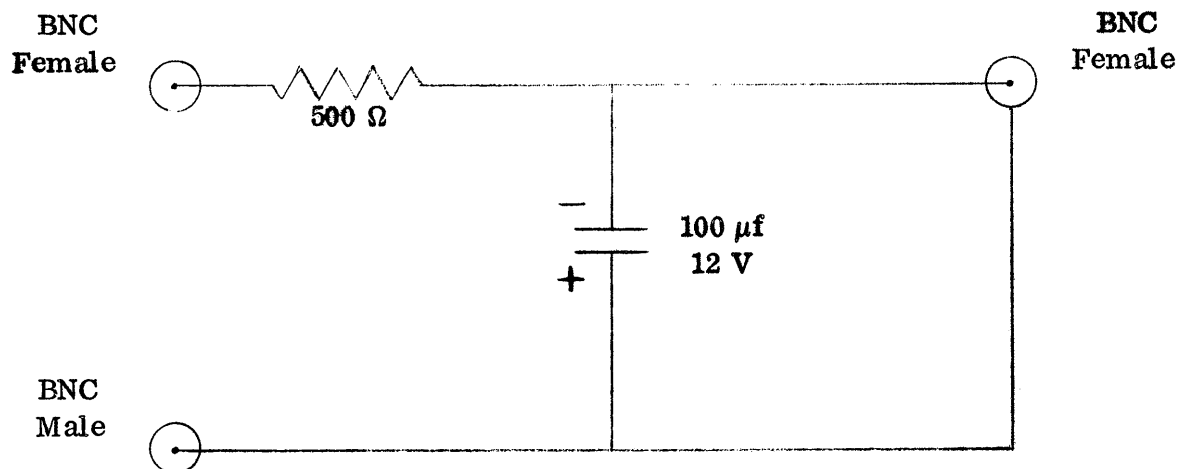

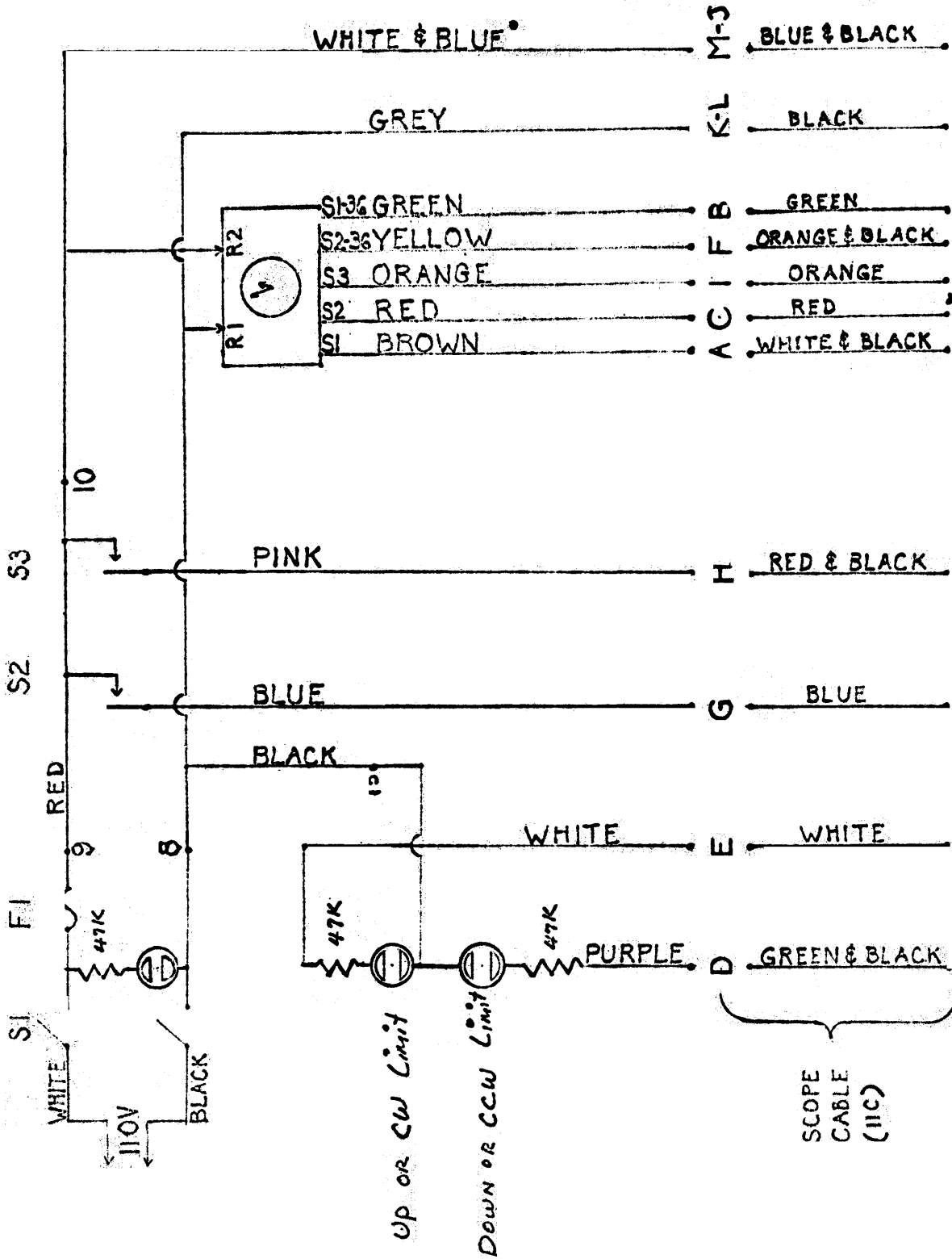

FI-2A AC FUSE
 S1-DPDT LINE SW.
 S2-PUSH-DOWN CW SW
 S3-PUSH-UP CCW SW
 Synchro - IU3 type

FOCUSING AND POLARIZATION
 CONTROL UNIT 85-5

FIGURE 20

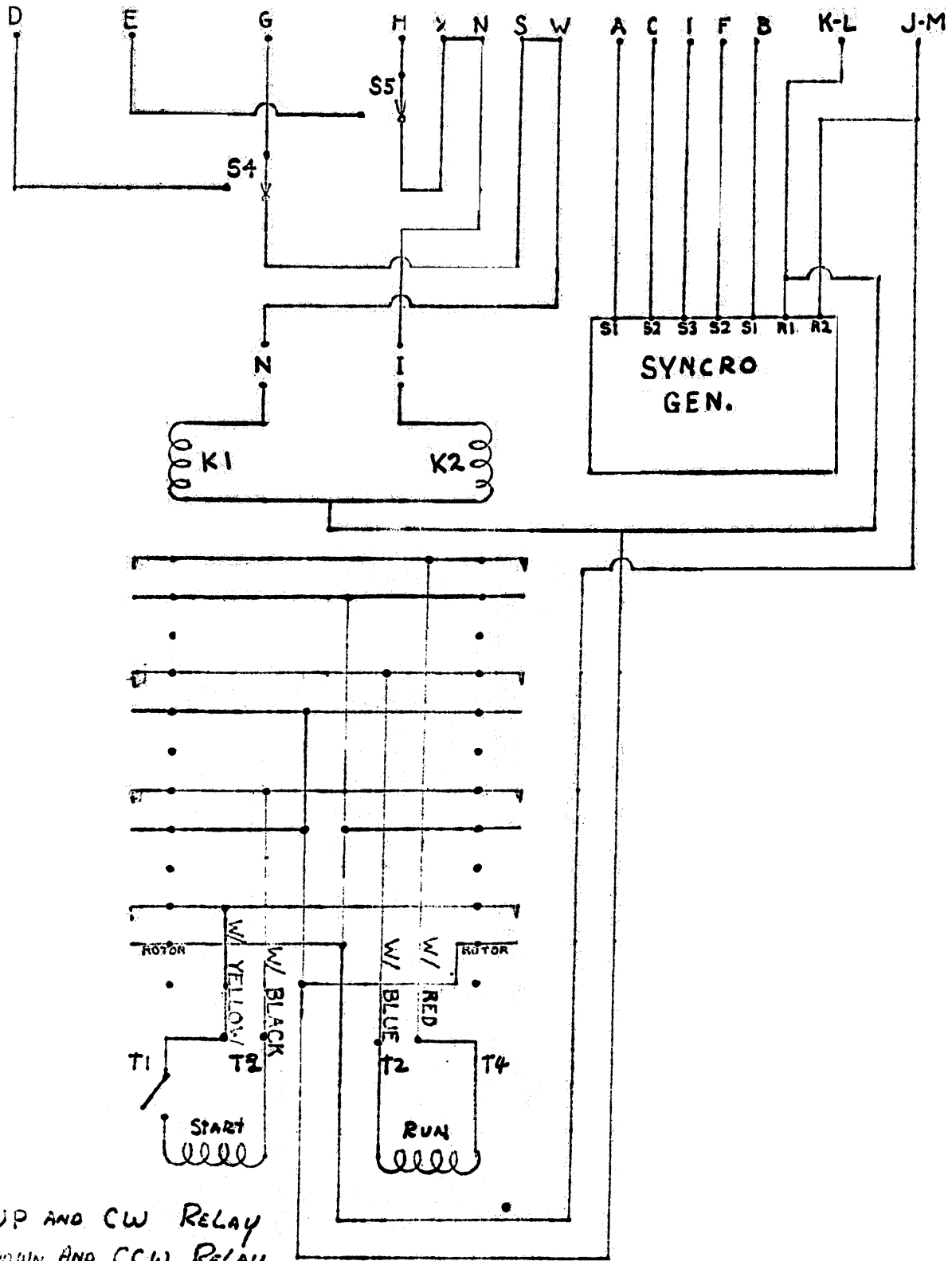

K1 - UP AND CW RELAY
 K2 - DOWN AND CCW RELAY
 SYNCR - S-A 4300 S
 MOTOR - BOSTON VMB
 S4 - UP AND CW LIMIT SW
 S5 - DOWN AND CCW LIMIT SW

FIGURE 21

FOCUSING AND POLARIZATION
 DRIVE UNIT 85-5

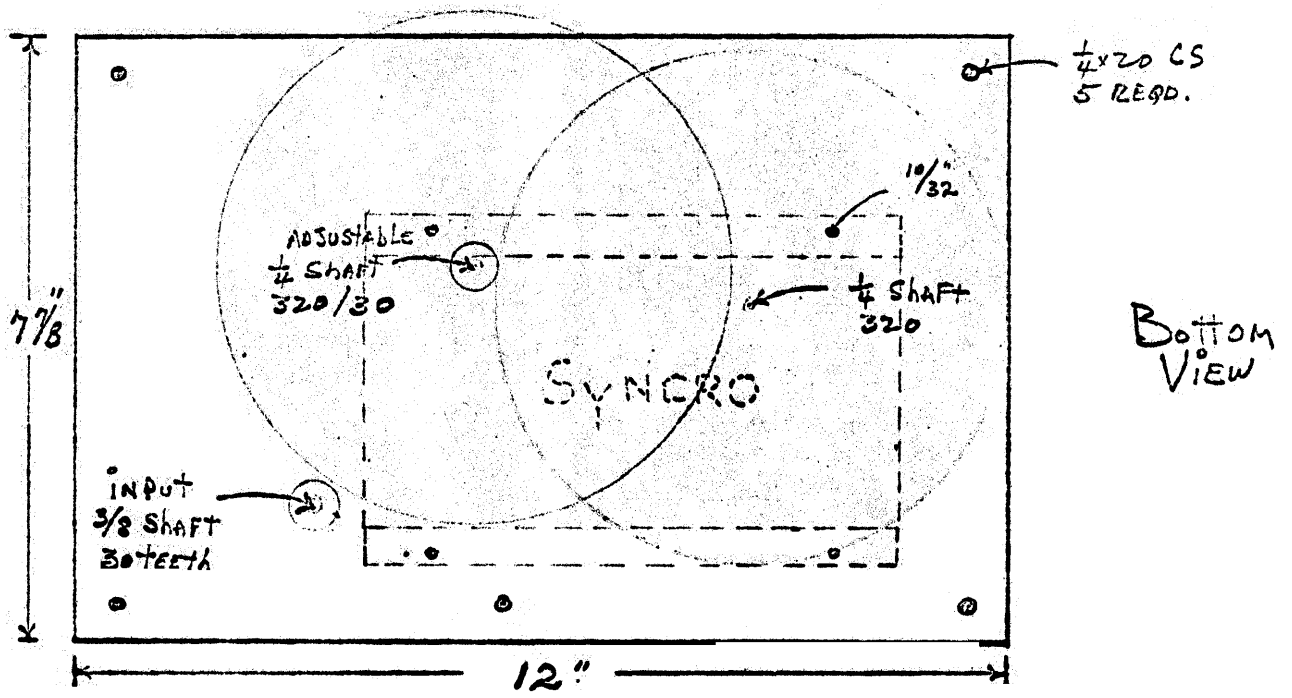
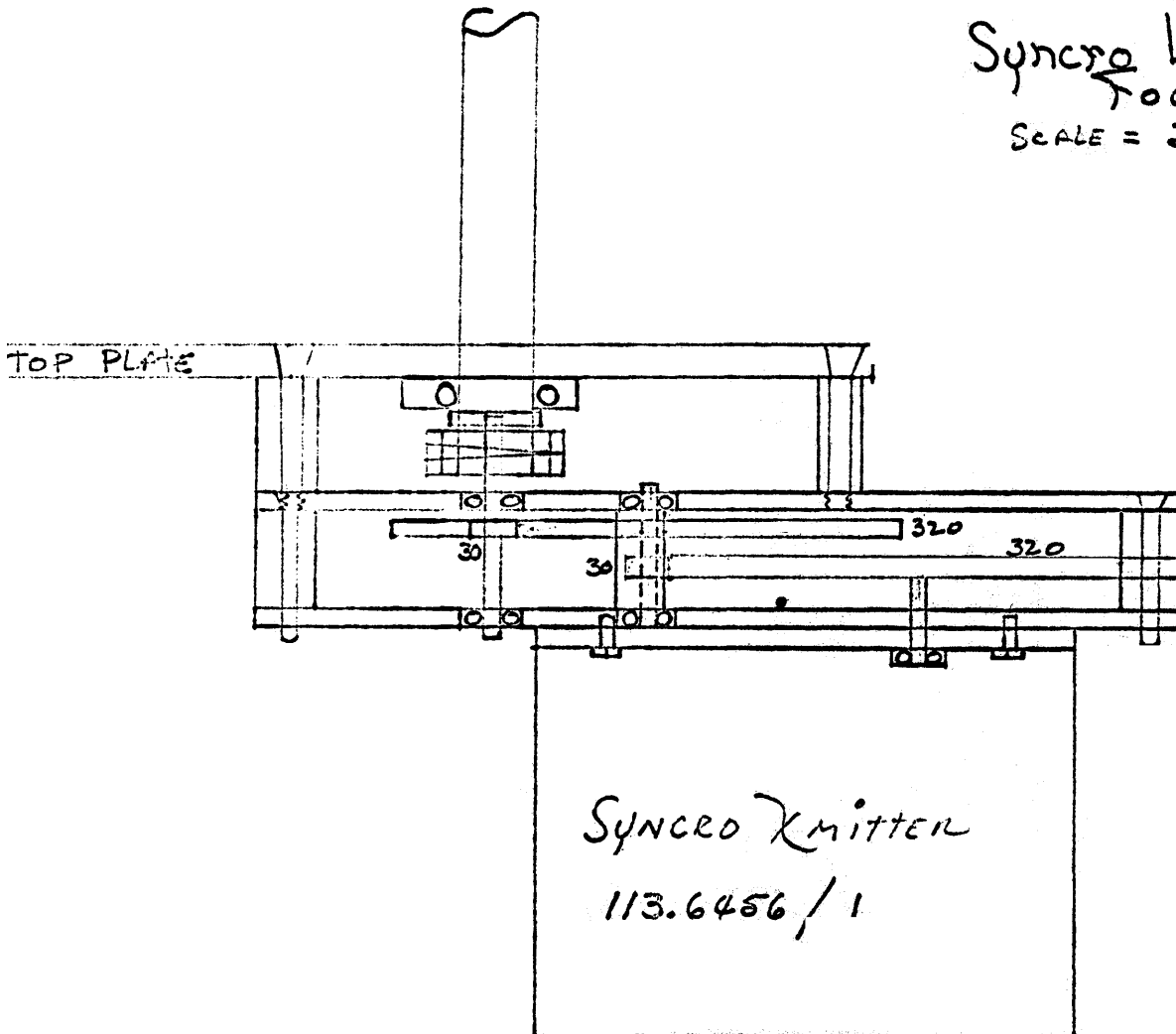

FIGURE 22

Syncro Layout For
Focus
SCALE = 259/IN



--- E-Plane
— H-Plane

FIGURE 23 — TYPICAL SCALAR FEED

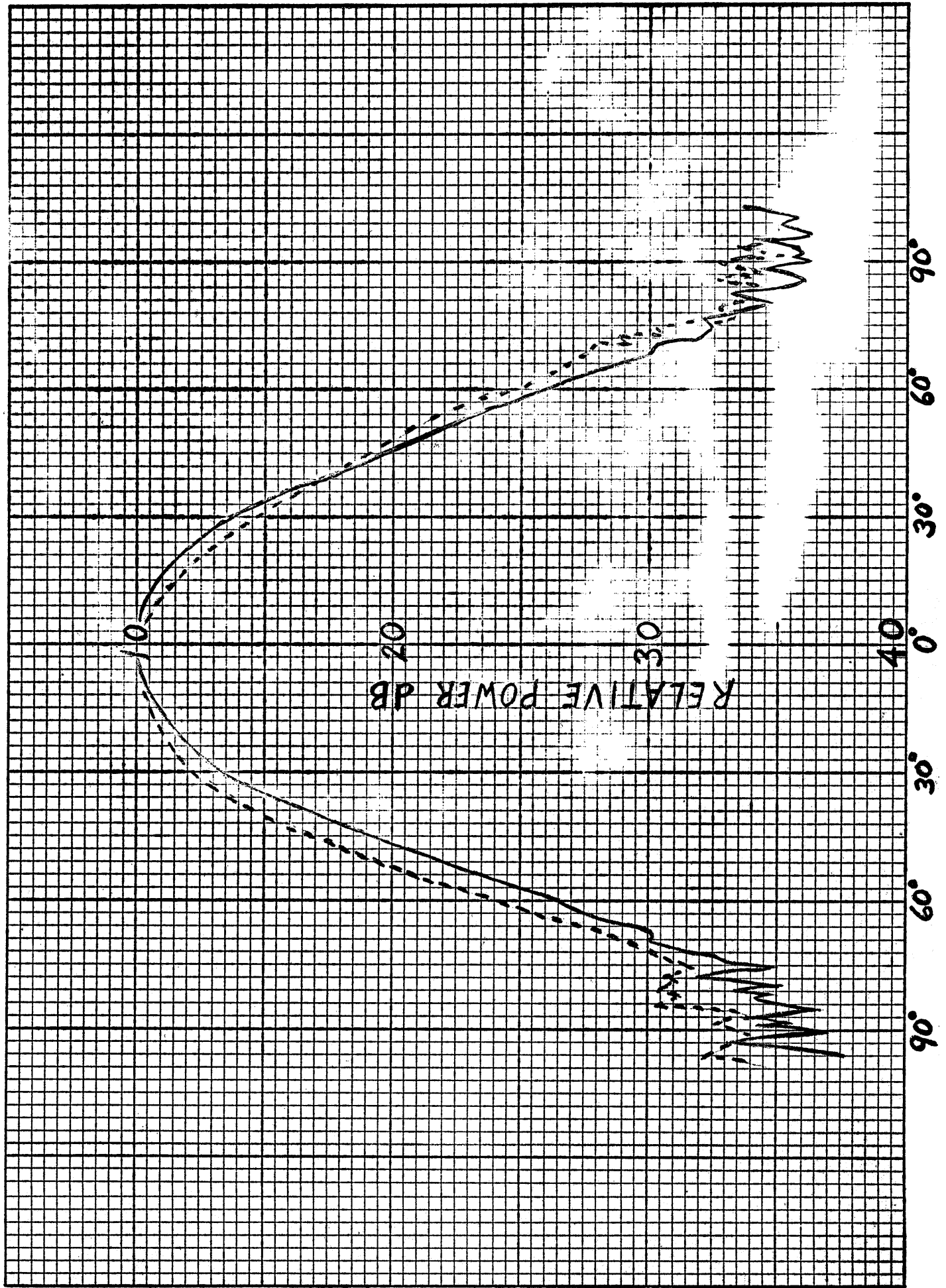

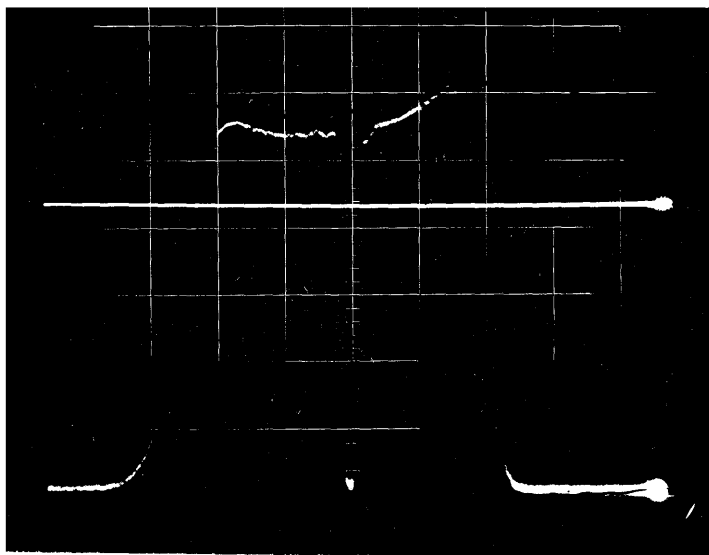

FIGURE 24 GAIN BANDPASS CHARACTERISTICS OF MIXER-PREAMP FOR 85-1 FRONT-END. REFERENCE LINE IS 1 dB POINT. GAIN 18.5 dB BW 38 MHz

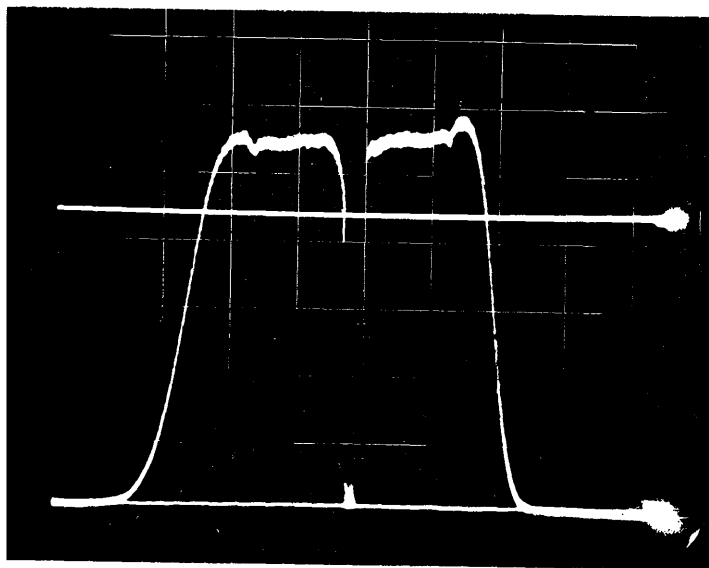

FIGURE 25 GAIN BANDPASS CHARACTERISTICS OF MAIN I.F. AMPLIFIER AND MIXER-PREAMP FOR 85-1 FRONT-END. REFERENCE LINE IS 1 dB POINT. GAIN OF I.F. IS 40 dB. BW IS LIMITED BY MIXER-PREAMP TO 38 MHz

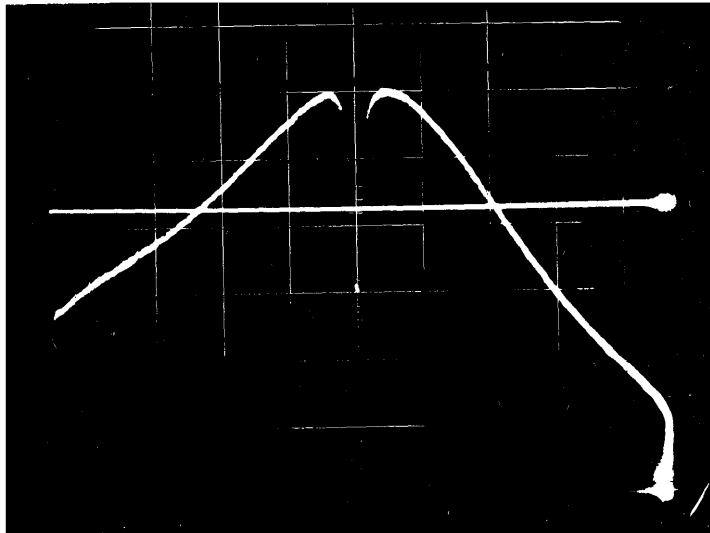

FIGURE 26 GAIN-BANDPASS CHARACTERISTICS OF AIL PARAMETRIC AMPLIFIER FOR 85-1 FRONT-END. SCOPE SENSITIVITY IS $200 \mu\text{v/cm}$. REFERENCE LINE IS 1 dB POINT. GAIN 15 dB BW 40 MHz

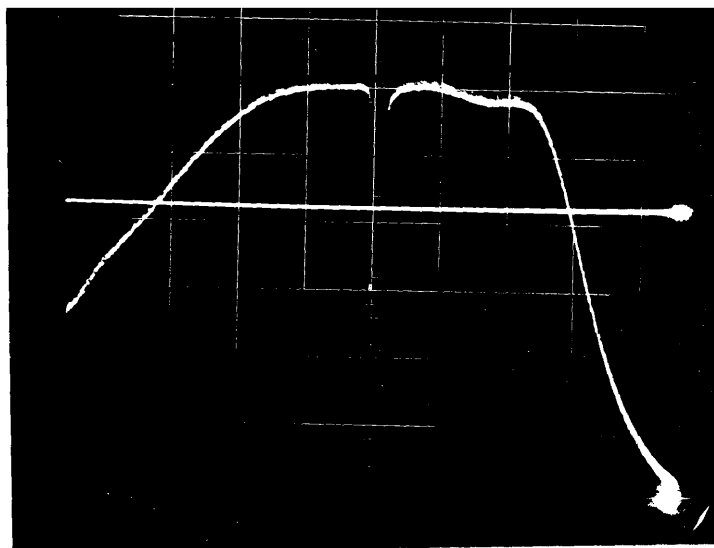

FIGURE 27 GAIN-BANDPASS CHARACTERISTICS OF MPC PARAMETRIC AMPLIFIER FOR 85-1 FRONT-END. SCOPE SENSITIVITY IS $200 \mu\text{v/cm}$. REFERENCE LINE IS 1 dB POINT. GAIN 15 dB BW 105 MHz RESPONSE FLAT 2740 MHz-2666 MHz = 74 MHz

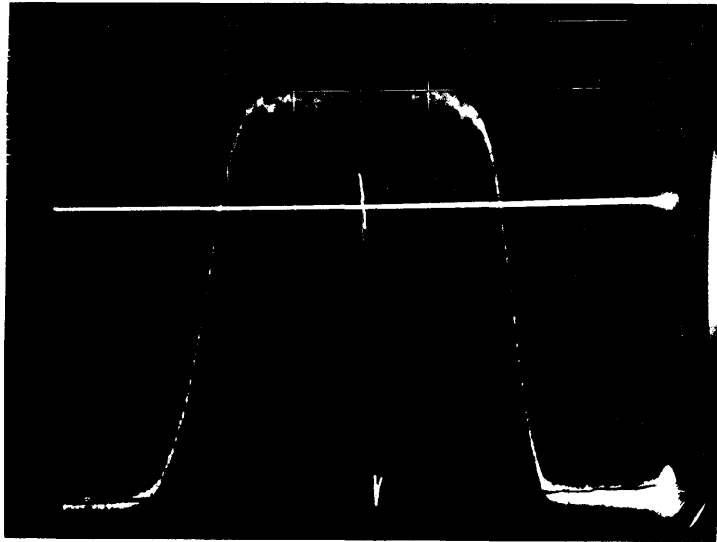

FIGURE 28 OVERALL SYSTEM GAIN-BANDPASS CHARACTERISTICS OF THE 85-1 FRONT-END. REFERENCE LINE IS 1 dB POINT. SYSTEM GAIN IS APPROX. 88 dB BW 38 MHz

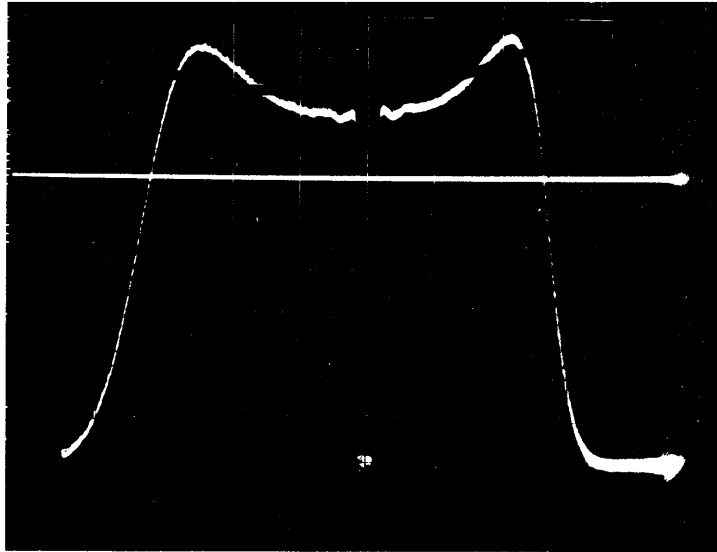

FIGURE 29 GAIN-BANDPASS CHARACTERISTICS OF MIXER-PREAMP FOR 85-2 FRONT-END. REFERENCE LINE IS 1 dB POINT. GAIN 20 dB BW 38MHz

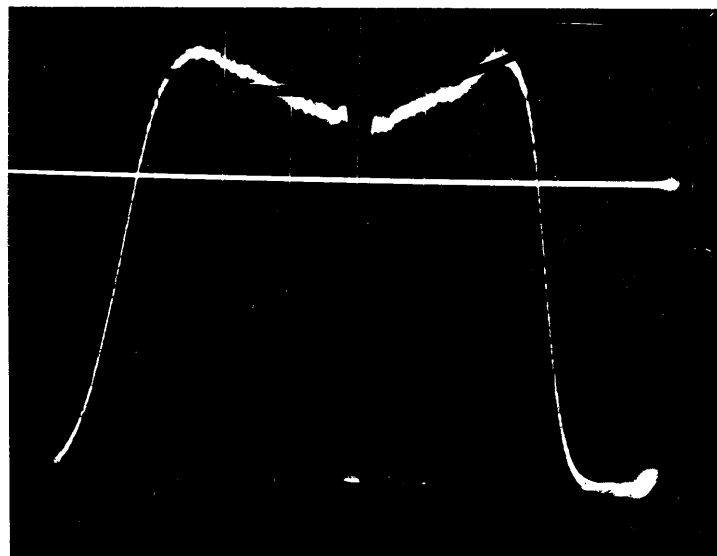

FIGURE 30 GAIN-BANDPASS CHARACTERISTICS OF MAIN I.F. AMPLIFIER AND MIXER-PREAMP FOR 85-2 FRONT-END. REFERENCE IS 1 dB POINT. GAIN OF THE I.F. AMPLIFIER IS 40 dB. BW IS LIMITED BY MIXER-PREAMP TO 38 MHz

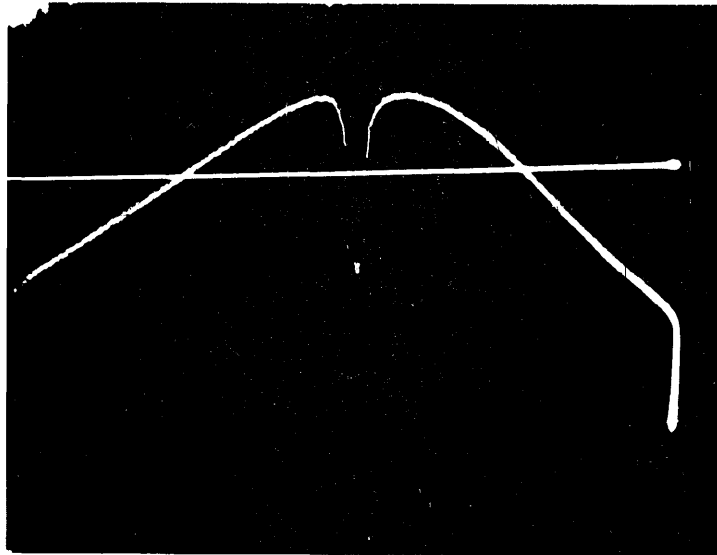

FIGURE 31 GAIN-BANDPASS CHARACTERISTICS OF AIL PARAMETRIC AMPLIFIER FOR 85-2 FRONT-END. SCOPE SENSITIVITY IS $200\mu\text{v/cm}$. REFERENCE LINE IS 1 dB POINT. GAIN 15 dB BW 37 MHz



FIGURE 32 GAIN-BANDPASS CHARACTERISTICS OF MPC PARAMETRIC AMPLIFIER FOR 85-2 FRONT-END. SCOPE SENSITIVITY IS $200\mu\text{v/cm}$. REFERENCE LINE IS 1 dB POINT. GAIN 15 dB BW 110 MHz RESPONSE FLAT 2725 MHz-2665 MHz = 60 MHz

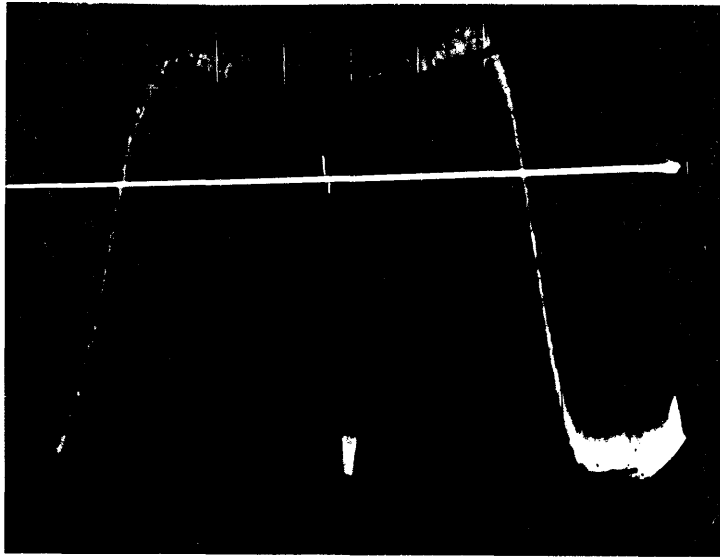

FIGURE 33 OVERALL SYSTEM GAIN-BANDPASS CHARACTERISTICS OF THE 85-2 FRONT-END. REFERENCE LINE IS 1 dB POINT. SYSTEM GAIN IS APPROX. 90 dB BW 37 MHz

Figure 34 ALL Paramp Before Modification

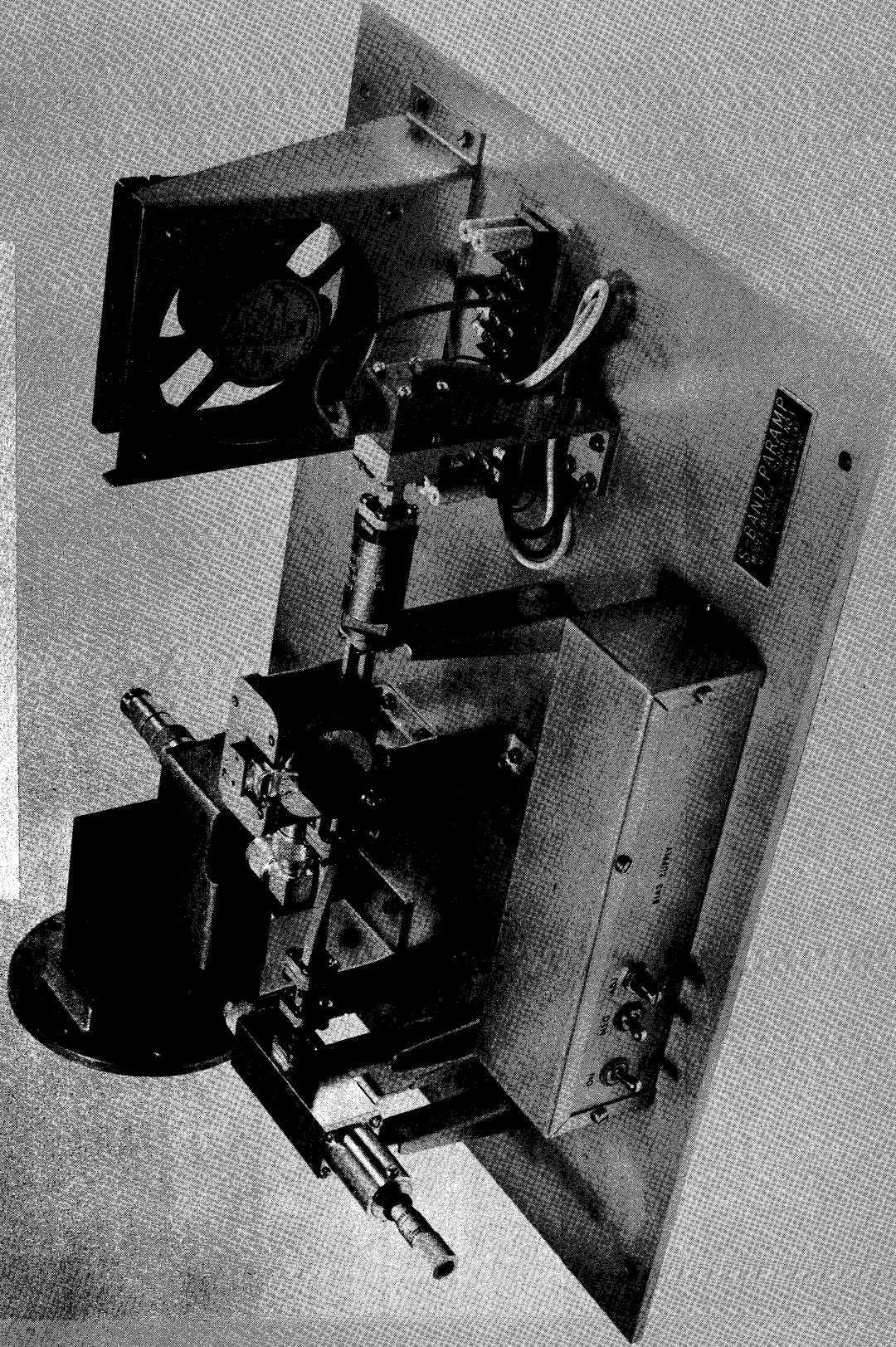

Figure 35 AIL Paramp After Modification

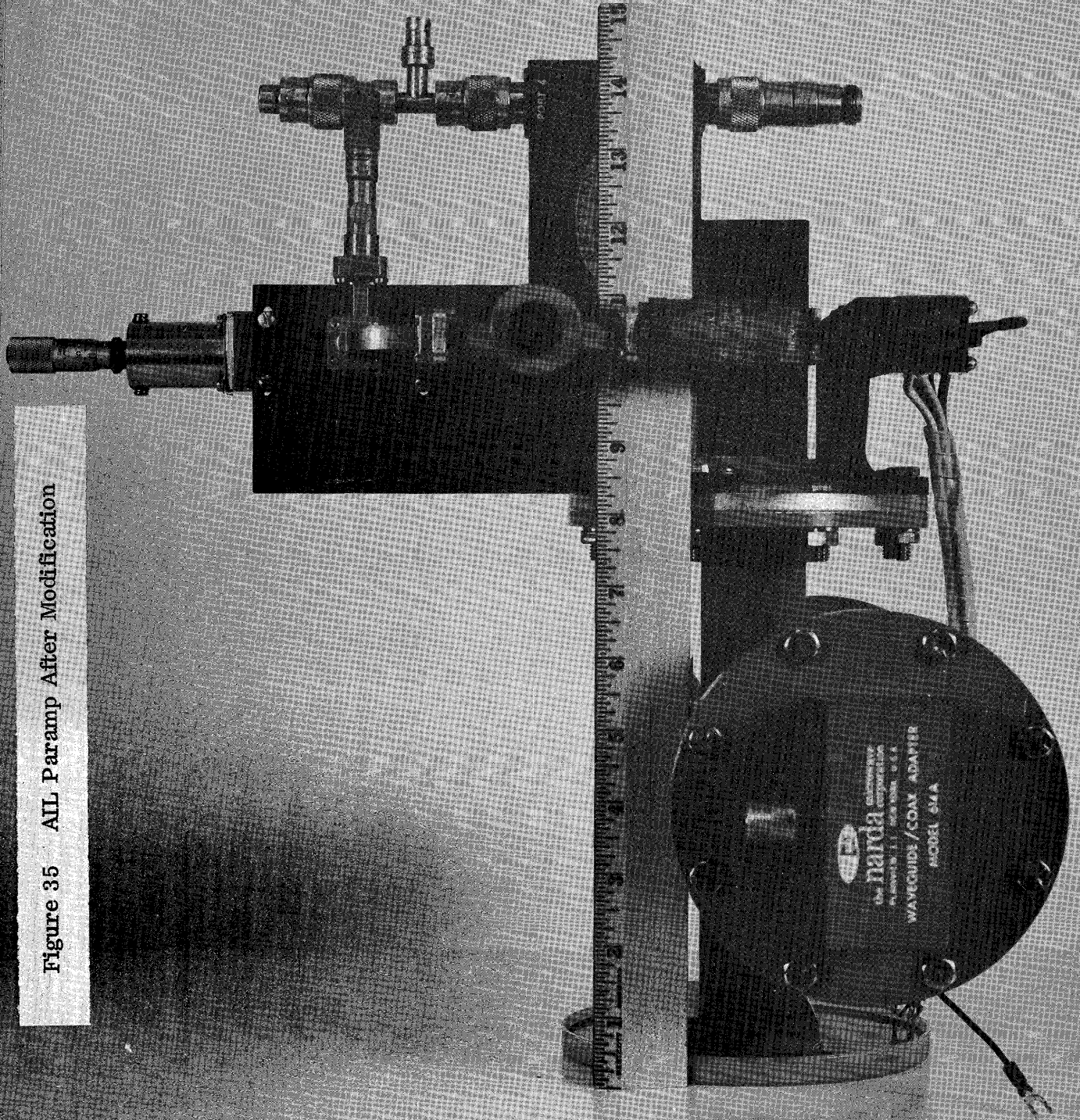

Figure 36 MPC Paramp After Modification

