

GBT Spectral-Line Data Reduction and Tutorials



David Frayer (Green Bank Observatory)





GBT CDE Material



Cornell 2017 July 10-11

Key Links

- [Remote GBO Login](#)
- [GBO Observers Web Page](#)
- [NRAO-GBT Practical Information for Astronomers Web Page](#)

Click to login into Green Bank

Presentations

GBT Spectral-line Data Reduction Demos

All demo's, data, and scripts are located at: /home/scratch/dfrayer/DATAdemo

- [DEMO basics](#) (Basics of GBTIDL)
- [DEMO frequency switching](#) (Frequency switching example)
- [DEMO sdfits HIsigref](#) (sdfits example, basic gbtidl scripting, and reducing HI data)
- [DEMO argus mapping](#) (Argus Mapping)
- [DEMO NGC6946 HI pipeline](#) (Example of the GBT pipeline)
- [DEMO argus frequency switching deep coadd](#) (Argus coadd of FSW HCN(1-0) data)

Observing Related Documentation and Links

- Observer Information
 - [GBT Proposer's Guide](#)

GBO startkde on Processing Machine

Browser tabs: dfrayer -- Sessions

Address bar: <https://ssh.gb.nrao.edu:3443>

Search: Search

Applications:

- ariel
- Firefox/ESS
- KDE
- titania

Terminal (xterm):

```
ssh planck startkde
```

Start

Background text: You have no sessions run

User: dfrayer

Footer: dfrayer@prospero, Build: 2.3.101, POWERED BY STARNET COMMUNICATIONS, Download the Desktop Client

Public
Processing
Machines:

- planck
- newton
- fourier
- arcturus

The GBT has a lot of different observation types and many different methods for reduction

- Standard gbtidl routines and the GBT pipeline supports VEGAS spectral-line data from position-switched or frequency-switched observations for receivers with noise diodes
- Pulsar data → Presto reduction package
- Mustang → separate Mustang package (Mason)
- VLBI → VLBA folks
- Radar → Radar folks
- W-band, Argus, SubBeamNod → Frayer
- Data reduction not supported for continuum observations or stokes polarization observations; however, non-official software exists

Reduction Software Documentation

GBTIDL:

-- User's Guide: http://www.gb.nrao.edu/GBT/DA/gbtidl/users_guide/

- Quick Reference:

http://www.gb.nrao.edu/GBT/DA/gbtidl/QRG_release.pdf

- Calibration documentation:

http://www.gb.nrao.edu/GBT/DA/gbtidl/gbtidl_calibration.pdf

- Reference Manuals:

User: <http://www.gb.nrao.edu/GBT/DA/gbtidl/release/user/>

Contrib: <http://www.gb.nrao.edu/GBT/DA/gbtidl/release/contrib>

sdfits:

<https://safe.nrao.edu/wiki/bin/view/Main/SdfitsDetails>

gbtpipeline:

<https://safe.nrao.edu/wiki/bin/view/GB/Gbtpipeline/PipelineRelease>

gbtgridder: (gbtgridder -h)

GBT Data Processing “Flow” Chart

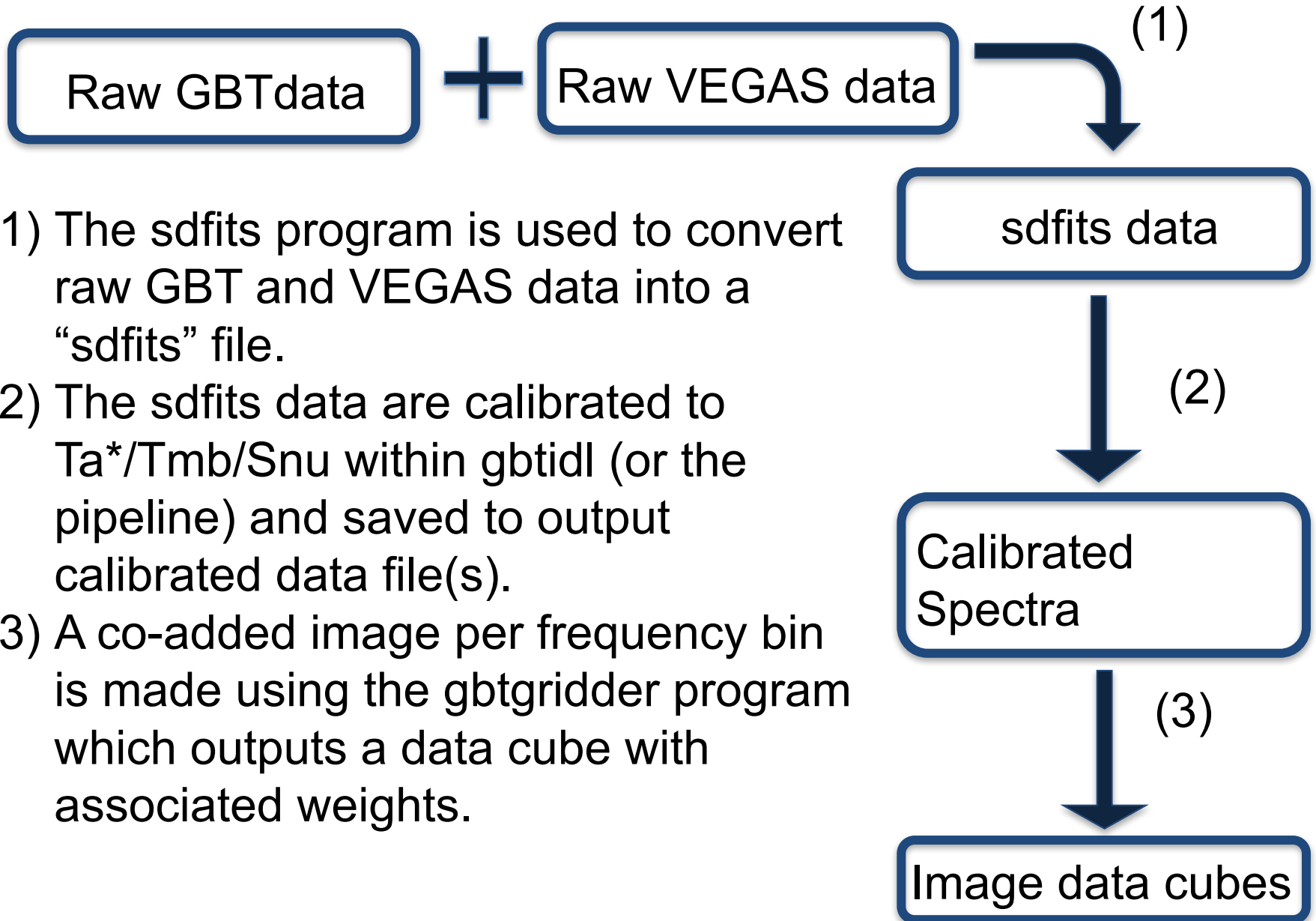

(1) The sdfits program is used to convert raw GBT and VEGAS data into a “sdfits” file.

(2) The sdfits data are calibrated to $T_a^*/T_{mb}/S_{nu}$ within gbtidl (or the pipeline) and saved to output calibrated data file(s).

(3) A co-added image per frequency bin is made using the gbtgridded program which outputs a data cube with associated weights.

The telescope measures:

T_a = “antenna temperature”

- $T_a(\text{total}) = T_{\text{source}} + \{T_{\text{rx}} + T_{\text{bg}} + T_{\text{atm}} + T_{\text{spill}}\}$
- Where $\{\dots\}$ = other contributions
- Want T_{source} , so carry out ON – OFF
- $T_a(\text{ON}) = T_{\text{source}} + \{\dots\}$
- $T_a(\text{OFF}) = \{\dots\}$
- So $T_a(\text{ON}) - T_a(\text{OFF}) = T_{\text{source}}$

➔ Need to carry out ON-OFF observations and there are different observing techniques for measuring ON-OFF

Different Observing Modes to derive the reference data (OFF)

Types of reference observations

➤ Frequency Switching

- In or Out-of-band

➤ Position Switching

- Reference-Off
- Mapping-Off

➤ Dual-Beam Position Switching

- **Nod** -- Move telescope
- **SubBeamNod** -- Move Subreflector

GBT Definition of T_a

$$T_a = \frac{(\text{ON} - \text{OFF})}{\text{OFF}} T_{\text{system}}$$

Blank Sky or other

From diodes, Hot/Cold loads, etc.

Determining T_{sys}

Noise Diodes

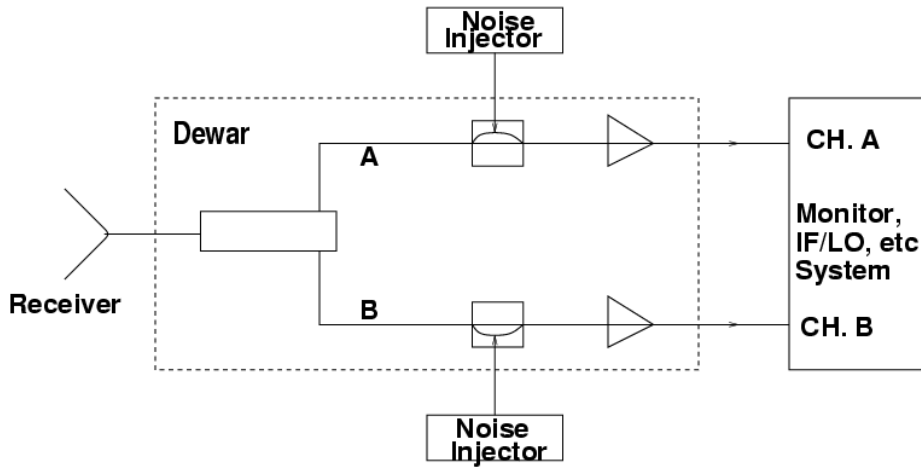

All GBT receivers besides 4mm, Argus, and Mustang use noise diodes.

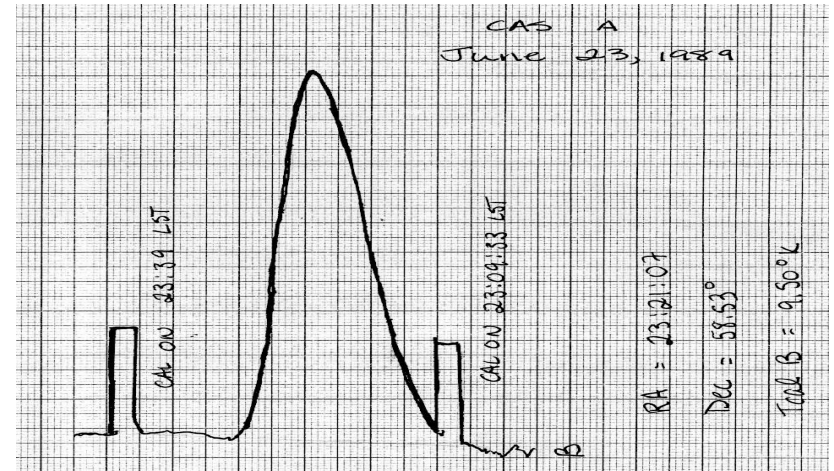

Determining T_{sys}

Noise Diodes

$$T_{sys} = T_{cal} * OFF / (ON - OFF)$$

GBT: Flicker diode on/off

$$T_{sys} = T_{cal} * OFF / (ON - OFF) + T_{cal} / 2$$

Typically choose low T_{cal} value to minimize T_{sys} and high T_{cal} value for very bright sources (for Rx that have two options)

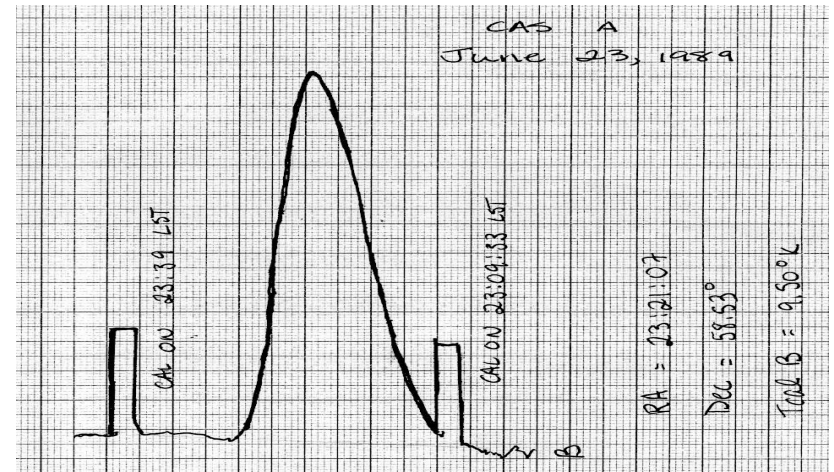

Determining T_{sys}

Hot & Cold Loads

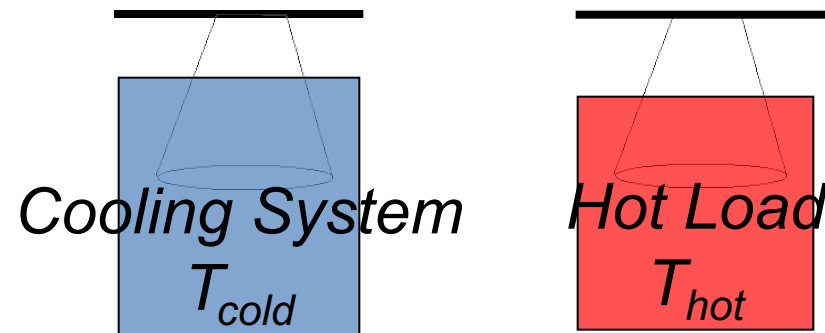

Gain: $g = (T_{hot} - T_{cold}) / (V_{hot} - V_{cold})$ [K/Volts]

$T_{sys} = g V_{off}$

Example GBT 4mm Rx

Temperature Scales

- $T_a = T_{\text{sys}} (\text{ON-OFF}) / \text{OFF}$ (GBT typically uses uncorrected antenna temperature)
- $T_a' = T_a \exp(\tau_o A)$ (corrected for atmosphere)
- $T_{\text{mb}} = T_a' / \eta_{\text{mb}}$ ($\eta_{\text{mb}} \sim 1.3 \eta_a$)
- $T_a^* = T_a' / \eta_l$ (Argus uses T_a^* , $\eta_l \sim 0.99$ for the GBT)
- $T_a' / S_v = 2.84 \eta_a$ (for the GBT)

Calibration:

Flux Density vs Antenna Temp vs Main-Beam Temp

$$P_{\text{rec}} = \frac{1}{2} A_e S_v \Delta\nu = k T_a' \Delta\nu$$

$$A_e = \eta_a (\pi/4) D^2$$

$$S_v = 3520 T_a' / (\eta_a [D/m]^2)$$

➔ $T_a' / S_v = 2.84 \eta_a$ for the GBT ($\eta_a = 0.71$ at low ν)

- Know S_v (use ALMA calibration database for 3mm and VLA calibration papers for <50GHz) and derive η_a from measured T_a'
- Measure FWHM from good pointing scans or within your image to derive η_{mb} and T_{mb} ; **$T_{\text{mb}} = T_a' / \eta_{\text{mb}}$**
- **$\eta_{\text{mb}} = 0.8899 \eta_a (\theta_{\text{FWHM}} 100\text{m} / \lambda)^2$** (assumes Gaussian beam, where beam FWHM is in radians)

GBO Data Directories

- **Home area:** `/users/user_name`
- **Scratch data area:** `/home/scratch/user_name`
- **Raw gbtdata** by project (e.g.,
AGBT16B_037_04):
`/home/gbtdata/AGBT16B_037_04`
- **Raw Vegas data** by project:
`/lustre/gbtdata/AGBT16B_037_04/VEGAS`
- **sdfits data** by project:
`/home/sdfits/AGBT16B_037/04`

Public Data Processing Machines with lustre access:

- newton, planck, fourier (192GB ram)
- euclid, thales (16GB ram)
- arcturus (132GB ram) {pipeline machine}

- Extra disk space for data processing:
/lustre/pipeline/scratch/user_name

gbtidl (=unipops [12m and 140ft reduction package] converted to IDL)

- Data access (connecting to sdfits file)
 - gbtidl> online
 - gbtidl> offline,'AGBT16B_037_04'
 - gbtidl> filein,'mysdfitsfile.fits'
 - gbtidl> summary

- User "pro" directory used by gbtidl:
/users/user_name/gbtidlpro

Standard Reduction scripts

□ Ta=Tsys(ON-OFF/OFF):

- getps, scan (position switch)
- getfs, scan (frequency switch)
- getnod, scan (nod data)
- getsigref, scan_on,scan_off

□ Raw passband

- gettp, scan (total power for scan)
- **gettp,scan,ifnum=ifnum,plnum=plnum,fdnum=fdnum,
sig_state=sig_state,subref=subref,wcalpos=wcalpos**
- getrec, rec (get an individual record, see list)

Some Basic GBTIDL Commands:

DEMO_basics

- `gbtidl> offline,'TGBT17A_506_11'`
- `gbtidl> summary` (give summary of session)
- `gbtidl> getsigref,6,7` (on,off position switch data reduction)
- `gbtidl> header` (provide some of the meta data in container 0)
- `gbtidl> gettp,6 & copy,0,2` get ON and copy to container 2
- `gbtidl> gettp,7 & copy,0,3` get OFF and copy to container 3
- `gbtidl> subtract,2,3` (ON-OFF) (container math)
- `gbtidl> divide,0,3` (ON-OFF)/OFF
- `gbtidl> scale,17.34` (multiply by T_{sys} to give $T_a = T_{\text{sys}} * (\text{ON-OFF}) / \text{OFF}$)
- `gbtidl> !g.s[0].units='Ta'` (changing meta data units from counts to T_a [K])
- `gbtidl> setregion` (select regions for baseline removal)
- `gbtidl> nfit,3` (use 3rd order polynomial for baseline fitting)
- `gbtidl> bshape` (fit baseline)
- `gbtidl> baseline` (remove baseline)
- `gbtidl> gsmooth,3,/decimate` (Gaussian smooth with width of 3 channels)
- `gbtidl> fitgauss` (fit Gaussian to data)
- `gbtidl> keep` (save current data in container 0 to output file `!g.s[0].units='Ta'`)

Frequency Switching Example:

DEMO_frequency_switching

- GBTIDL -> offline,'TGBT17A_506_11'
- GBTIDL -> summary (give summary of session)
- GBTIDL -> getfs,10 (reduce frequency switched data)
- GBTIDL -> gettp,10,sig=1 (look at one freq)
- GBTIDL -> freeze
- GBTIDL -> gettp,10,sig=0 (look at other freq)
- GBTIDL -> oshow
- Change between MHz and Channels at top of IDL plotting window to show how this works

GBTIDL position-switch Demo:

DEMO_sdfits_Hlsigref

- filein,'sdfits_example' (from DATAdemo directory)
- summary
- gettp,56 (look at passband)
- getsigref,56,57 (look at one ON-OFF pair)
- dotri,56,70 (reduces ON-OFF-ON sequence and co-adds data for scans 56-70)
- Smooth data and baseline removal

Example script: “dotri.pro”

```
pro dotri,sc1,sc2
;;16A054 HI project
;;does ON-OFF-ON reduction for scans sc1-->sc2
;;Session 1: sc1=16, sc2=39
sclear
for ii=sc1,sc2,3 do begin
  print,'combining ON-OFF',ii,ii+1
  getsigref,ii,ii+1,plnum=0
  accum
  getsigref,ii,ii+1,plnum=1
  accum
  print,'combining ON-OFF',ii+2,ii+1
  getsigref,ii+2,ii+1,plnum=0
  accum
  getsigref,ii+2,ii+1,plnum=1
  accum
endfor
ave
copy,0,10
return
end
```

Argus Mapping Demo:

DEMO_argus_mapping

- Raw data (40min observations, 167k spectra) first calibrated and reduced at about 0.2 sec per spectrum which takes ~9hrs) using `argus_mapcal.pro` → `save15a901_27.fits`
- `filein,'save15a901_27.fits'` (from DATAdemo directory)
- `getrec,50000`
- `for i=70000,70200 do begin & getrec,i & accum & end`
- `ave (13CO near channel 6000)`
- Run `gbtgridder`
- `$gbtgridder -c 5900:6100 -a 7 -noline -nocont -o test3 save15a901_27.fits`
 - Channels 5900:6100
 - Averaging over 7 channels
 - Avoid having software do continuum subtraction (already done)
- `$casaviewer` (or `ds9`) to view output cube (`test3_cube.fits`)

L-band Pipeline Demo:

DEMO_NGC6946_HI_pipeline

- `Gbtidl> offline,'TGBT17A_506_11'`
- `Gbtidl> summary` (map scans 14-26 and reference scan is 27 want on HI which is IFNUM=0)
- `$gbtpipeline -i`
`/home/sdfits/TGBT17A_506_11/TGBT17A_506_11.raw.`
`vegas -m 14:26 -refscan 27 -w 0 -c 1700:2300 -a 50`
 - Firsts calibrates the data then grids the data
 - Map-scans are 14:26
 - Reference scan is 27
 - IFNUM= 0 (spectral window = 0)
 - Channels 1700:2300
 - Average 50 channels
- `$casaviewer` (or `ds9`) to view output cube data

Argus deep frequency switching coadd:

DEMO_argus_frequency_switching_deep_coadd

- GBTIDL -> offline,'TGBT17A_506_06'
- GBTIDL -> vanecal,53 (derive atmospheric parameters and T_{sys}^* for all beams)
- GBTIDL -> argus_fsw,55,53,ifnum=0,fdnum=9 (calibrate one scan for center beam)
- GBTIDL -> for i=55,86 do begin & argus_fsw,i,53,ifnum=0,fdnum=9 & accum &end
- GBTIDL -> ave (Coadd all scans for one beam)
- GBTIDL -> argus_fsw_coadd,55,86,53,ifnum=0 (coadd all scans for all beams [takes 20min])

Saving data and Mapping

- fileout,'mysave.fits'
- Reduce data like you want then type: keep
- After calibration within gbtidl can run gbtgridder (eg.):

```
gbtgridder -c 11000:11251 -a 7 --noline -  
nocont -o myout mysave.fits
```

```
→ myout_cube.fits myout_weight.fits
```

Running the Pipeline

- Works for receivers with noise diodes (designed originally for KFPA):
- `%gbtpipeline -i my.sdfits.raw.vegas -m 14:24 -refscan 13,26`

(where 14-24 are the map scans and 13 and 26 are the reference scans)

➔ will calibrate and do the gridding

Example of reducing W-band DCR Data (daisy scan of point source)

- `sdfits -backends=dcr TRCO_20160927 -scans=1`
- `IDL>ftab_ext,INdcr,[7,13,15,19,59,60],data,ra,dec,scan,plnum,fdnum,exten_no=1`
- {calibrate data based on plnum and fdnum:
`data1=gain*data}`
- `IDL> hpfilt,data1,100,10,ndata`
- `IDL>mymap=griddata(ra,dec,ndata,dimension=[60,60])`
- `IDL>smmap=filter_image(mymap,FWHM_gaussian=3)`
- `IDL> atv,smmap`